

SECTION C: TECHNICAL REGULATIONS

Version:	Issue 12
Status:	PUBLISHED
Date:	10/06/2025
WMSC approval date:	10/06/2025

CONVENTION:

Black Text: Text unchanged from 2026 F1 technical Regulations - Section C – Issue 11. Approved by the WMSC on 26/02/2025

Pink Text: Changes approved by the WMSC 10/06/2025.

[Red Text]: Information on applicable Governance and relevant Advisory Committee

[Orange Text]: Reference information on relevant Guidance Document(s): non-binding and non-regulatory

[Green Text]: Comments / explanations / indication of further work: non-binding and non-regulatory

ARTICLE C1: GENERAL PRINCIPLES **7**

C1.1	Formula One World Championship	7
C1.2	Regulatory Framework	7
C1.3	Interpretation of and amendments to these Technical Regulations	7
C1.4	Dangerous construction	8
C1.5	Compliance with the regulations	8
C1.6	New systems or technologies	8
C1.7	Duty of Competitor and PU Manufacturer	9

ARTICLE C2: CONVENTIONS AND FUNDAMENTAL DIMENSIONS **10**

C2.1	Coordinate systems and conventions	10
C2.2	Principal Planes	11
C2.3	Fundamental Dimensions	11
C2.4	Reference Volumes and Surfaces	12
C2.5	Precision of Numerical Values	12

ARTICLE C3: AERODYNAMIC COMPONENTS **13**

C3.1	Aerodynamic Components or Bodywork	13
C3.2	General Principles	13
C3.3	Legality Checking	16
C3.4	Component Definition	18
C3.5	Floor Bodywork	19
C3.6	Plank and Skids	23
C3.7	Front Bodywork	27

C3.8	Rear Bodywork	29
C3.9	Tail and Exhaust Tailpipe	31
C3.10	Front Wing (FW)	32
C3.11	Rear Wing (RW)	39
C3.12	Final Assembly	43
C3.13	Bodywork not defined in Articles C3.5 to C3.12	44
C3.14	Wheel Components	45
C3.15	Wheel Bodywork Assembly	49
C3.16	Apertures	50
C3.17	Suspension and Driveshaft Fairings	53
C3.18	Aerodynamic Component Flexibility	55
C3.19	Aerodynamic Component construction	60
ARTICLE C4: MASS		62
C4.1	Minimum mass	62
C4.2	Mass distribution	62
C4.3	Ballast	62
C4.4	Adding during the Race or Sprint Session	63
C4.5	Reference Mass of the driver and Driver Ballast	63
C4.6	Heat Hazard Mass Increase	63
C4.7	Determination of Nominal Tyre Mass	63
ARTICLE C5: POWER UNIT		64
C5.1	Engine specification	64
C5.2	Power Unit Energy Flow	65
C5.3	Turbo Charger	69
C5.4	Power unit geometrical constraints and dimensions	70
C5.5	Mass and centre of gravity	72
C5.6	Engine intake air	73
C5.7	Variable geometry systems	74
C5.8	Exhausts	74
C5.9	Fuel systems	74
C5.10	Ignition systems	75
C5.11	Ancillaries	75
C5.12	Power unit torque or power demand	75
C5.13	Power unit control	76
C5.14	Engine high rev limits	78
C5.15	Starting the engine	78
C5.16	Stall prevention systems	78
C5.17	Energy Recovery System (ERS)	78
C5.18	MGU-K	80

C5.19	Energy Store	81
C5.20	ES design and installation	82
C5.21	ERS General electrical safety	83
C5.22	Replacing power unit parts	85
C5.22	Oil and coolant systems and charge air cooling	85
C5.24	Component Classification	86
C5.23	Single ICE Mode	86
ARTICLE C6: FUEL SYSTEM		87
C6.1	Fuel tanks	87
C6.2	Fittings and piping	87
C6.3	Fuel tank fillers	88
C6.4	Refuelling	88
C6.5	Fuel draining and sampling	88
C6.6	Fuel System Hydraulic Layout	89
ARTICLE C7: OIL AND COOLANT SYSTEMS AND CHARGE AIR COOLING		92
C7.1	Location of lubricating oil tanks	92
C7.2	Location of lubricating oil system	92
C7.3	Oil and coolant lines	92
C7.4	Heat exchangers	92
ARTICLE C8: ELECTRICAL SYSTEMS		93
C8.1	Software and electronics inspection	93
C8.2	Control electronics	94
C8.3	Start systems	94
C8.4	Data acquisition	94
C8.5	Telemetry	95
C8.6	Driver inputs and information	96
C8.7	Master switch	96
C8.8	Driver radio	97
C8.9	Accident analysis	97
C8.10	Accident data	99
C8.11	FIA Marshalling system	99
C8.12	Track signal information display	99
C8.13	Impact warning system	99
C8.14	Installation of electrical systems or components	100
C8.15	Timing transponders	100
C8.16	Cameras and camera housings	100
C8.17	Electromagnetic radiation	102
C8.18	Sensor signals	102

ARTICLE C9: TRANSMISSION SYSTEM		103
C9.1	Fundamental provisions	103
C9.2	Clutch control	103
C9.3	Clutch Disengagement System (CDS)	105
C9.4	Homologated Gearbox and Component Classification	105
C9.5	Gearbox Dimensions	106
C9.6	Gear ratios	106
C9.7	Reverse gear	107
C9.8	Gear changing	107
C9.9	Torque transfer systems	107
C9.10	Driveshafts	108
C9.11	Driveshaft Torque Sensors	108
C9.11.	Structural Connection to Survival Cell	108
ARTICLE C10: SUSPENSION, STEERING SYSTEMS, WHEELS AND TYRES		109
C10.1	Legality ride height	109
C10.2	Sprung suspension	109
C10.3	Outboard suspension	110
C10.4	Inboard suspension	112
C10.5	Steering	113
C10.6	Suspension Uprights	113
C10.7	Wheel rims	114
C10.8	Tyres	116
C10.9	Wheel attachment and retention	118
C10.10	Dimensions	118
ARTICLE C11: BRAKE SYSTEM		119
C11.1	Brake circuits and pressure distribution	119
C11.2	Brake callipers	119
C11.3	Brake discs and pads	120
C11.4	Brake pressure modulation	120
C11.5	Liquid cooling	120
C11.6	Rear brake control system	120
C11.7	Supply of Brake Friction and Brake System Hydraulic components	120
ARTICLE C12: SURVIVAL CELL		121
C12.1	General Requirements	121
C12.2	Survival cell specifications	121
C12.3	Intrusion Protection	124
C12.4	Roll Structures	125
C12.5	Cockpit Specification	126

C12.6	Cockpit Padding	128
C12.7	Front Floor Structure	130
C12.8	Seat fixing and removal	130
C12.9	Driver Fit Information	131
ARTICLE C13: SAFETY STRUCTURES AND HOMOLOGATION		132
C13.1	General Principles	132
C13.2	Survival Cell Frontal Impact Test	132
C13.3	Roll Structure Testing	134
C13.4	Survival Cell Load Tests	136
C13.5	Side Impact Structure	139
C13.6	Front Impact Structure	143
C13.7	Rear Impact Structure	146
C13.9	Headrest Load Test	148
C13.10	Wheel Rim Impact Test	148
ARTICLE C14: SAFETY EQUIPMENT		150
C14.1	Fire Extinguishers	150
C14.2	Rear view mirrors	150
C14.3	Rear lights	151
C14.4	Safety Tethers	152
C14.5	Safety Harnesses	153
C14.6	Driver Cooling System	153
C14.7	Lateral Safety lights	154
C14.8	Driver's Drink System	154
ARTICLE C15: MATERIALS		155
C15.1	General Principles	155
C15.2	Permitted Materials (Components Outside the PU Perimeter)	155
C15.3	Specific Prohibitions and Restrictions (Components Outside the PU Perimeter)	158
C15.4	Specific Exceptions (Components Outside the PU Perimeter)	159
C15.5	Prescribed and Homologated Laminates (Components Outside the PU Perimeter)	160
C15.6	Materials, processes and construction – General (Components inside the PU Perimeter)	161
C15.7	Materials and construction – Components (Components inside the PU Perimeter)	162
C15.8	Materials and construction – Pressure charging and exhaust systems (Components inside the PU Perimeter)	164
C15.9	Materials and construction – Energy recovery, storage systems and electronic systems (Components inside the PU Perimeter)	165
ARTICLE C16: FUEL AND ENGINE OIL		166
C16.1	Basic principles	166
C16.2	Fuel properties	167

C16.3	Composition of the fuel	168
C16.4	Fuel approval	169
C16.5	Fuel sampling and testing at a Competition	169
C16.6	Engine oil definitions	170
C16.7	Engine oil properties	171
C16.8	Composition of the engine oil	171
C16.9	Engine oil approval	171
C16.10	Sampling and testing at a Competition	171
C16.11	Recycling of Engine Oil	172
ARTICLE C17: COMPONENTS' CLASSIFICATION		173
C17.1	General Principles	173
C17.2	Listed Team Components (LTC)	174
C17.3	Standard Supply Components (SSC)	177
C17.4	Transferable Components (TRC) and Free Supply Components (FSC)	178
C17.5	Open Source Components (OSC and OSCNT)	179
C17.6	Defined Specification Components (DSC)	181
C17.7	List of LTC, SSC, TRC, OSC, OSCNT, and DSC	182
ARTICLE C18: POWER UNIT COMPONENTS' CLASSIFICATION		183
C18.1	General Principles	183
C18.2	Listed Power Unit Components (LPUC)	184
C18.3	Standard Supply Power Unit Components (SSPUC)	186
C18.4	Open-Source Power Unit Components (OSPUC)	187
C18.5	Defined Specification Power Unit Components (DSPUC)	188
C18.6	List of LPUC, SSPUC, OSPUC and DSPUC	189
APPENDIX C1: DEFINITIONS		190
APPENDIX C2: REGULATION VOLUMES		204
APPENDIX C3: DRAWINGS		220
APPENDIX C4: POWER UNIT SYSTEMS, FUNCTIONS, COMPONENTS AND SUPPLY PERIMETER		225
APPENDIX C5: HOMOLOGATION AND DEVELOPMENT OF POWER UNITS, FUEL AND OIL FOR 2026-2030		235
APPENDIX C6: COMPONENTS' CLASSIFICATION AND PERIMETER		240
APPENDIX C7: APPROVED CHANGES FOR FUTURE YEARS		252
APPENDIX C8: SUPPLY OF POWER UNITS, FUEL AND OIL FOR 2026-2030		254

ARTICLE C1: GENERAL PRINCIPLES

Advisory Committee: TAC and PUAC

Governance: F1 Commission / PU Manufacturers' Governance Agreement / WMSC

C1.1 Formula One World Championship

- C1.1.1** The FIA will organise the FIA Formula One World Championship (the "Championship") which is the property of the FIA and comprises two titles of World Champion, one for drivers and one for constructors. It consists of the Formula One Grand Prix races which are included in the Formula One calendar and in respect of which the ASNs and organisers have signed organisation agreements with the FIA. All the participating parties (FIA, ASNs, organisers, Competitors, **Power Unit** (PU) Manufacturers, Suppliers and circuits) undertake to apply as well as observe the rules governing the Championship and, where applicable, must hold FIA Super Licences which are issued to drivers, competitors, officials, organisers and circuits, or register in accordance with the provision of the Regulations.
- C1.1.2** The Championship and each of its **Competitions** are governed by the FIA in accordance with the Regulations, as defined below.

C1.2 Regulatory Framework

- C1.2.1** The regulations applicable to the Championship are the International Sporting Code (the **ISC**), the Formula One Technical Regulations (the "Technical Regulations"), the Formula One Sporting Regulations (the "Sporting Regulations"), and the Formula One Financial Regulations (the "Financial Regulations"), as amended from time to time, together referred to as the "Regulations".
- C1.2.2** Subject to Article C1.2.3, these Regulations are issued by the FIA and apply to the whole calendar year referred to in the title and to the Championship taking place within that calendar year. Any changes made by the FIA for safety reasons may come into effect without notice or delay.
- C1.2.3** These Technical Regulations regard the FIA Formula One World Championship starting from 2026, and additionally outline various requirements that the PU Manufacturers and their Suppliers must satisfy in the period 2022–2025 to be able to homologate a **Power Unit** for the 2026 FIA Formula One World Championship.

C1.3 Interpretation of and amendments to these Technical Regulations

- C1.3.1** The definitive text of the Technical Regulations shall be the English version which will be used should any dispute arise as to their interpretation.
- C1.3.2** Headings in this document are for ease of reference only and do not affect the meaning of the Technical Regulations.
- C1.3.3** Unless stated otherwise, references to "Articles" herein are to articles of these Technical Regulations.
- C1.3.4** In the sense of the Regulations, terms referring to natural persons are applicable to any gender.

C1.3.5 Any terms not defined in these Technical Regulations have the meaning given to them in the “FIA 2022 Formula 1 Technical Regulations – Issue 12” (the “2022 Technical Regulations”). In the event that ascribing the meaning of a defined term in the 2022 Technical Regulations to an undefined term in these Technical Regulations results in a significant impact to the design of the 2026 **Power Unit**, PU Manufacturers bound by these Technical Regulations may ask the FIA for guidance and the FIA will then issue guidance on the meaning of the relevant term. Such guidance will be communicated by the FIA to all PU Manufacturers.

C1.3.6 Any amendments to these Technical Regulations that do not relate specifically to the **Power Unit** or that relate to matters of form rather than substance (such as re-numbering, reference corrections, etc.) will not be subject to the approval of the PU Manufacturers. Any amendments to these Technical Regulations that relate to substantive matters concerning the **Power Unit** will be subject to the prior approval of the PU Manufacturers in accordance with the 2026 F1 PU Governance Agreement, as referenced in Article 1.1 of Appendix C8.

C1.4 Dangerous construction

The stewards may prohibit the participation of a vehicle whose construction is deemed to be dangerous. Should the relevant information become apparent during a session, such a decision may apply with immediate effect.

C1.5 Compliance with the regulations

Formula 1 Cars must comply with these regulations in their entirety at all times during a **Competition**.

Should a Competitor or PU Manufacturer introduce a new design or system or feel that any aspect of these regulations is unclear, clarification may be sought from the FIA Formula One Technical Department. If clarification relates to any new design or system, correspondence must include:

- a. A full description of the design or system.
- b. Drawings or schematics where appropriate.
- c. The Competitor or PU Manufacturer's opinion concerning the immediate implications on other parts of the car of any proposed new design.
- d. The Competitor or PU Manufacturer's opinion concerning any possible long-term consequences or new developments which may come from using any such new designs or systems.
- e. The precise way or ways in which the Competitor or PU Manufacturer feels the new design or system will enhance the performance of the car.

C1.6 New systems or technologies

Any new system, procedure or technology not specifically covered by these Technical Regulations, but which is deemed permissible by the FIA, will only be admitted until the end of the Championship during which it is introduced. Following this the Formula One Commission will be asked to review the technology concerned and, if they consider (in their sole discretion) that such new system, procedure, or technology adds no value to Formula One in general, it may be specifically prohibited by the FIA.

C1.7 Duty of Competitor and PU Manufacturer

It is the duty of each Competitor to satisfy the FIA and the stewards that its Formula 1 Car complies with these regulations in their entirety at all times during a **Competition**. With regard to PUs used on a Formula 1 Car, this duty and responsibility also extends to the PU Manufacturer.

The design of the car, its components and systems shall, except for safety features, demonstrate their compliance with these regulations by means of physical inspection of hardware or materials. Unless explicitly requested by an Article, no mechanical design may rely upon software inspection as a means of assessing compliance.

To further demonstrate compliance with Articles C3.2.2 and C3.18.1, Competitors may be required to submit calculations, or to run with analytic devices specified by the FIA.

Due to their nature, the compliance of electronic systems may be assessed by means of inspection of hardware, software, and data.

CAD models may be requested by the FIA to check compliance with the Regulations. Such models should be supplied in a format and by a method specified by the FIA. In such cases, scanning technology will be used by the FIA to check that the physical car is the same as the inspected CAD models.

Each Competitor and each PU Manufacturer must ensure that all relevant personnel (whether employee, consultant, contractor, secondee or any other type of permanent or temporary personnel) associated with its participation in the Championship are appropriately informed with respect to the ways in which their areas of responsibility may impact the compliance of the Competitor and/or PU Manufacturer (as applicable) with the Regulations.

Each Competitor and each PU Manufacturer must ensure that the FIA ethics and compliance hotline with respect to the Regulations is clearly communicated to all relevant personnel.

ARTICLE C2: CONVENTIONS AND FUNDAMENTAL DIMENSIONS

Advisory Committee: TAC

Governance: F1 Commission / WMSC

C2.1 Coordinate systems and conventions

C2.1.1 Car Coordinate System

The “**Car Coordinate System**” is a right-handed Cartesian [X, Y, Z] coordinate system ~~will be used in these regulations,~~ and is defined in the following way:

- a. The X axis is the longitudinal direction of the car and increases rearwards.
- b. The Y axis is the transverse direction of the car and increases to the (driver’s) right-hand side.
- c. The Z axis is the vertical direction and increases upwards.

C2.1.2 Further conventions

- a. If no units are specified, it is implicit the unit will be in millimetres
- b. The terms “inboard” or “outboard”, when used in reference to the Y coordinate, respectively refer to closer to or further away from the plane $Y=0$.
- c. A suffix may be used for local coordinates in specific rules, (e.g. X_w, Y_w, Z_w), where these local axes are defined within a specific Article for local use.
- d. Planes will be referred to as the axis to which they are normal to (e.g. X-Plane or $X_A = 300$ plane).
- e. A wheel is defined to be in the straight-ahead position when its rotational axis lies in an X-Plane.

Unless otherwise specified:

- f. the positive side of the Y axis is used in the various Articles and it is implicit that a symmetrical rule applies for the other side of the car.
- g. any measurements and references will be with the wheels in the straight-ahead position.
- h. when a viewing direction is stated, “front” and “rear” are parallel to the X axis, “side” is parallel to the Y axis (in the direction towards the plane $Y = 0$) and “above”, “below” and “plan” are parallel to the Z axis.
- i. directions of angles, slopes and incidences are taken in context of the right-handed Cartesian coordinate system defined in C2.2.1. For example, a positive slope within a Y-Plane would be characterised by positively increasing X and Z components.
- j. references to axis aligned geometry are aligned to the **Car Coordinate System** defined in C2.1.1.
- k. a load vector ([x, y, z]kN) will have components parallel to the axes of the **Car Coordinate System**.

C2.1.3 Wheel Coordinate System

The “**Wheel Coordinate System**” is a local right-handed Cartesian [X_w, Y_w, Z_w] coordinate system ~~will be used for each wheel,~~ and is defined in the following way ~~for each wheel~~:

- a. The origin of the Wheel Coordinate System is the intersection of the rotational axis of the wheel and the inboard plane of the **Wheel Rim**.
- b. The X_W axis lies in the inboard plane of the **Wheel Rim** and increases in the rearward direction. With the wheel in the straight-ahead position and the car at its legality ride height, the X_W axis is parallel to the car's X-Axis.
- c. The Y_W axis is coincident with the wheel's axis of rotation and increases towards the plane $Y=0$. Referring to this axis, the terms "inboard" or "outboard" respectively refer to closer to or further away from the plane $Y = 0$.
- d. The Z_W axis lies in the inboard plane of the **Wheel Rim** and increases upwards.
- e. Once the Wheel Coordinate System is defined as above, then it maintains a fixed orientation relative to the suspension upright at all other suspension articulations.

C2.2 Principal Planes

- a. The **Plane $Z = 0$** is defined as a horizontal plane sitting at the bottom of the sprung part of the car, except for the **Plank Assembly** defined in Article C3.6.
- b. The **Plane $Y = 0$** is defined as the plane of symmetry of the car.
- c. The **Plane $X_A = 0$** is defined as the X-Plane that lies on the forward limit of the **Survival Cell**.
- d. The **Plane $X_C = 0$** is defined as ~~an~~ the X-Plane at the rear of the **Cockpit**.
- e. The planes **$X_F = 0$** and **$X_R = 0$** are defined as ~~a~~ the X-Planes which respectively pass through the origin of the two front or two rear **Wheel Coordinate Systems**, ~~as defined in Article C2.9.3~~ ~~C2.1.3~~, with the wheels in the straight-ahead position and the car at the Legality Ride Height.
- f. The plane **$X_{DIF} = 0$** is defined as the X-Plane containing the axis of rotation of the final drive as defined in Article 9.7.1.
- g. The plane **$X_{PU} = 0$** is defined as the X-Plane which passes through the mounting face of the connections between the **ICE** and the **Survival Cell**, as defined in Article C5.4.17.
- h. The plane **$X_{FIS} = 0$** is defined as the X-plane passing through the forward most point of the Front Impact Structure.

C2.3 Fundamental Dimensions

C2.3.1 Width

Except for the tyres, ~~and~~ the **Wheel Rims**, ~~and parts attached to the~~ **Wheel Rims** as defined in Articles ~~C10.7.2 and~~ C10.7.6, no part of the car may lie more than 950mm from the plane $Y=0$ at Legality Ride Height.

C2.3.2 Height

Except for the **Plank Assembly**, no part of the car may lie directly below the **Trim and Combination** of the following **Reference Volumes**:

- a. **RV-FLOOR-BODY.**
- b. **RV-BIB.**

- c. **RV-FLOOR-FOOT.**
- d. **RV-FLOOR-SIDEWALL.**
- e. **RV-FLOOR-FENCE.**

C2.3.3 Wheelbase

The distance between the planes $X_F = 0$ and $X_R = 0$ must be less than or equal to 3400mm at Legality Ride Height.

C2.3.4 Front Wheel Position

The plane $X_F = 0$ must lie between $X_A = 0$ and $X_A = 150$ inclusive.

C2.3.5 Cockpit Position

The distance between $X_A = 0$ and $X_C = 0$ must be greater than or equal to 1830mm and less than or equal to 2030mm.

C2.3.6 Rear Bulkhead Position

The distance between $X_C = 0$ and $X_{PU} = 0$ must be greater than or equal to 360mm

C2.4 Reference Volumes and Surfaces

“Reference Volumes” and “Reference Surfaces” and their position in space are defined in Appendix C2 using the **Car Coordinate System** and are used throughout the Regulations for geometrical constraints. For convenience, **Reference Volumes** are preceded by the prefix “RV-” and **Reference Surfaces** by the prefix “RS-”.

C2.5 Precision of Numerical Values

Any numerical values specified in these Regulations as limits (maxima or minima), will be considered to be the limits regardless of the decimals quoted.

ARTICLE C3: AERODYNAMIC COMPONENTS

Advisory Committee: TAC

Governance: F1 Commission / WMSC

C3.1 Aerodynamic Components or Bodywork

“Aerodynamic Components” or “Bodywork” are parts of the car in contact with the **External Air Stream**.

- a. The following components are **Bodywork**:
 - i. all components described in Article C3.
 - ii. inlet or outlet cooling ducts, up to the component they provide cooling for.
 - iii. inlet ducts for the **Power Unit** (air boxes) up to the air filter.
 - iv. primary heat exchangers, as defined in Article C7.4.1 (b).
- b. The following components are not Bodywork:
 - i. cameras and camera housings, as defined in Article C8.16.
 - ii. rear view mirrors as defined in Article C14.2.
 - iii. the ERS status light.
 - iv. parts associated with the mechanical functioning of the **Power Train**, transmission of power to the wheels, and the steering system, provided none are designed to achieve an aerodynamic effect.
 - v. **Wheel Rims** and tyres.
 - vi. brake disc assemblies, calipers, and pads.

C3.2 General Principles

C3.2.1 Objectives of Article C3

The primary objectives of Article C3 are:

- a. to promote close racing by minimising the aerodynamic performance loss when one car follows another.
- b. to ensure aerodynamic performance remains compatible with the required operation performance of the PU.

To assess these objectives, **F1 Teams** may be asked to provide relevant information to the FIA upon request.

The Intellectual Property of this information remains with the **F1 Team**, will be protected, and will not be disclosed to any third parties.

C3.2.2 Aerodynamic Influence

Except for the driver-adjustable bodywork specified in Articles C3.10.10 and C3.11.6, and minimal parts related to their operation, as well as Aerodynamic and flexible seals allowed by Articles C3.10.11, C3.14, C3.16.3 and C3.17.7, all **Aerodynamic Components** or **Bodywork** must:

- a. be rigidly constructed and immobile relative to their defined Frame of Reference defined in Article C3.4.
- b. ~~These components must also~~ provide a uniform, solid, hard, continuous, and impervious surface at all times.

Where an **Aerodynamic Component** complies with a test defined in Article C3.18, it will be considered compliant with (a) above for the deflection tested.

Any device or structure designed to bridge the gap between the sprung part of the car and the ground is strictly prohibited.

Apart from necessary parts for the adjustments described in Articles C3.10.10 and C3.11.6, and incidental movements from the steering system, any car system, device, or procedure that alters the aerodynamic characteristics of the car through driver movement is forbidden.

Furthermore, the aerodynamic effect of any component not classified as **Bodywork** must be incidental to its primary function. Designs intended to enhance any such aerodynamic effects are prohibited.

C3.2.3 Symmetry

All **Bodywork** must be nominally symmetrical with respect to $Y = 0$. Therefore, unless otherwise specified, any regulation in Article C3 concerning one side of the car will be assumed to be valid for the other side of the car including references to the maximum number of components allowed per side.

Minimal exceptions to the requirement of symmetry of this Article will be accepted for the installation of non-symmetrical mechanical components, for asymmetrical cooling requirements or for asymmetrical angle adjustment of the **FW Primary and Secondary Flap**, provided this adjustment is not controlled by the FIA Standard ECU.

Bodywork on the **Unsprung Mass** must respect this Article when the suspension position of each wheel is virtually reorientated so that its **Wheel Coordinate System** axes are parallel to their respective axis of the **Car Coordinate system**.

C3.2.4 Component Bodywork

Unless otherwise stated, all individual **Bodywork Components** described in Articles C3.5 to C3.11, and in Article C3.14, prior to any **Trim and Combination** operations, and before the addition of **Apertures**, must:

- a. be single volumes that are simply connected.
- b. in any X, Y and Z plane, or any X_w , Y_w and Z_w plane for **Wheel Bodywork**, only contain a single section.

C3.2.5 Trim and Combination

A “**Trim and Combination**” operation can only be performed once the parts to be trimmed are fully defined. The only regions of a volume that can be removed as part of a trimming process are those that are internal to the body they are trimmed by. Once parts are trimmed and combined, and any **Fillet Radius** or **Edge Radius** permitted by the relevant Article is applied, the resultant volume must

maintain both continuity and tangency in any X, Y, and Z plane at the boundaries between the adjacent sections of the parts. Unless otherwise stated:

- a. The elective trimming of volumes beyond or outside of any overlap is not permitted.
- b. **Trim and Combination** operations must result in a single volume.

~~C3.2.5~~ **Tangent Continuity**

~~Unless otherwise stated, the **Aerodynamic Surfaces** of all Bodywork defined in Articles C3.5 to C3.11, and Article C3.14, must be **Tangent Continuous**.~~

C3.2.6 Fillet and Edge Radius

A “**Fillet Radius**” is formed by rounding an internal corner (included angle less than 180 degrees) with a concave surface by only adding material, whilst an “**Edge Radius**” is created by smoothing an external corner (included angle greater than 180 degrees) with a convex surface by only removing material.

In both instances, the resulting surface must consist of arcs that adhere to specified radius limits, connect two fully defined surfaces tangentially without inflection, and align perpendicularly to their intersection. Unless otherwise stated, both Fillet and Edge Radii may vary in size along the boundary perimeter, but these changes must be continuous.

If a discontinuity in tangency exists at the trailing edge where a **Fillet Radius** has joined parts, a Closed Aerodynamic Fairing may be added immediately behind the trailing edge. This fairing must:

- a. maintain both continuity and tangency ~~in any X, Y and Z plane~~ with the filleted parts.
- b. fit within an ~~Acute Circular Cone~~ **Acute Circular Cone** whose:
 - i. **base radius is 1.2 times the minimum radius necessary to fully enclose the preceding *Fillet Radii* and any trailing edge immediately adjacent to the *Fillet Radii*.**
 - ii. **height is three times the maximum trailing edge *Fillet Radius*.**
- c. comply with Article C3.2.4 (a).

~~Furthermore, except when applied to Suspension and Driveshaft Fairings and Floor Winglets, all Fillet and Edge Radii and all Closed Aerodynamic Fairings must lie in their entirety within the union of:~~

- ~~c. the Reference Volumes that contain the parts to which these features are being applied;~~
- ~~d. the internal volume of a notional **Fillet Radius** that:~~
 - ~~i. is applied at the intersection of Reference Volumes that contain the parts to which these features are being applied~~
 - ~~ii. has a radius equal to the maximum size permitted by the Trim and Combination of the relevant Article.~~

C3.2.7 Pressure Tappings

Pressure measuring apertures are permitted on the car, provided they:

- a. have an internal diameter of no more than 2mm.

- b. are flush with the underlying geometry.
- c. are only connected to pressure sensors or are completely blanked.

C3.2.8 Section and Article Titles

Section and Article Titles within Article C3 have no regulatory value.

C3.3 Legality Checking

C3.3.1 Digital legality checking

Assessment of geometric compliance with Article C3 will be carried out digitally using CAD models provided by the teams. In these models:

- a. Components may only be designed to the edge of a **Reference Volume**, or with a precise geometrical feature, or to the limit of a geometrical criterion (save for the normal round-off discrepancies of the CAD system), when the regulations specifically require an aspect of the bodywork to be designed to this limit, or it can be demonstrated that the design does not rely on lying exactly on this limit to conform to the regulations, such that it is possible for the physical bodywork to comply.
- b. Components that must follow a precise shape, surface or plane, must be designed without any tolerance, save for the normal round-off discrepancies of the CAD system.
- c. Bodywork required to be visible from a prescribed direction may include surfaces parallel to that direction, provided it can be shown that such parallel surfaces could instead be drawn at an infinitesimally small, included angle and still comply with all relevant Articles.

C3.3.2 Physical legality checking

Cars may be measured during a **Competition** to check their conformance to the CAD models discussed in Article C3.3.1 and/or to ensure they remain inside the **Reference Volumes**.

- a. Unless otherwise stated, a tolerance of $\pm 3\text{mm}$ will be accepted for manufacturing purposes only with respect to the CAD surfaces. Where measured surfaces lie outside of this tolerance but remain within the **Reference Volumes**, an **F1 Team** may be required to provide additional information (e.g. revised CAD geometry) to demonstrate compliance with the regulations. Any discrepancies contrived to create a special aerodynamic effect or surface finish are not permitted.
- b. Irrespective of (a), geometrical discrepancies at the limits of the **Reference Volumes** must be such that the measured component remains inside the **Reference Volume**.
- c. A positional tolerance of $\pm 2\text{mm}$ will be accepted for the **Front Wing Bodywork, Rear Wing Bodywork, Exhaust Tailpipe**, and **Tail**. This will be assessed by realigning each of the groups of **Reference Volumes** and **Reference Surfaces** that define the assemblies, by up to 2mm, from their original position, to best fit the measured geometry.
- d. Irrespective of (b), and except for regions within the four holes defined in Article C3.6, a tolerance of $Z = \pm 2\text{mm}$ will be accepted for parts of the car lying on the $Z = 0$ plane, within $-375 \leq Y \leq 375$ and ahead of $X_R = 0$.
- e. Minimal discrepancies from the CAD surfaces will also be accepted in the following cases:

- i. Minimal repairs carried out on **Aerodynamic Components** and approved by the FIA.
- ii. Tape, provided it does not achieve an aerodynamic effect not otherwise permitted by Article C3.
- iii. Junctions between **Bodywork** panels.
- iv. Local **Bodywork** fixing details.

C3.3.3 Datum Points

All cars must be equipped with optical target mountings in the following locations. Unless otherwise stated, all positions have two targets positioned symmetrically about $Y = 0$.

- a. On the top of the **Survival Cell**, more than 80mm from $Y=0$, and between $X_A = 0$ and $X_A = 300$.
- b. On the top of the **Survival Cell**, more than 140mm from $Y = 0$, and close to $X_C = -875$.
- c. On the side of the **Survival Cell** between $X_A = 850$ and $X_C = 0$.
- d. On the side of the **Survival Cell** close to the rear mounts of the **Secondary Roll Structure**.
- e. Within an axis-aligned cuboid with an interior diagonal defined by points $[X_C = 0, -80, 970]$ and $[X_C = 150, -175, 870]$.
- f. On the lower surface of the **Survival Cell**, symmetrically about $Y = 0$, between $X_A = 0$ and $X_A = 500$, and more than 70mm from $Y = 0$.
- g. On the lower surface of the **Survival Cell**, symmetrically about $Y = 0$, between $X_C = -300$ and $X_C = 100$, and more than 150mm from $Y = 0$.
- h. A single probed point on the **RIS** or **Gearbox Case**.

In all cases, a file containing the coordinates of the required datum points must be supplied for each **Survival Cell**.

Full details of the requirements are given in the document [FIA-F1-DOC-C007](#).

C3.3.4 Supports for Scrutineering

All cars must be equipped with 4 pads of diameter ~~40mm~~ 20mm that will be used to support the car during scrutineering. The pads:

- a. must be rigidly mounted to the **Survival Cell**, **ICE** or **Gearbox Case** as appropriate.
- b. ~~The pads~~ must be on ~~the~~ a Z-Plane between $Z=2$ and $Z=5$ and will be used to determine the location of the plane $Z = 0$ when inspecting the underside of the car.
- c. ~~must have an M8x1.25 hole in the centre with at least 4 complete threads.~~
- d. ~~Pads~~ must be in the following locations:
 - i. two positioned symmetrically about $Y = 0$, at the same X-Plane as the centre of the central hole in the plank assembly, defined in C3.6.1 (c) and 150mm from $Y = 0$.
 - ii. two positioned symmetrically about $Y = 0$ at the same X-plane as the centre of the rearmost hole in the plank assembly, defined in C3.6.1 (c) and ~~125mm~~ 105mm from $Y = 0$.

Details of the mounting requirements are given in the document [FIA-F1-DOC-C007](#).

C3.4 Component Definition

The permitted bodywork and relevant **Frame of Reference** for each group is defined in the following Articles.

C3.4.1 Bodywork part of the sprung mass of the car

The only permissible Sprung Mass Bodywork is defined under Articles C3.5 to C3.13 and Articles C3.1.1 (a) (ii) to (iv). The Frame of Reference for all Sprung Mass Bodywork is the **Car Coordinate System**.

Any **Bodywork** subject to Final Assembly as per Article C3.12, must first be classified under one of the groups specified in Articles C3.5 to C3.11.

~~Except for any Aerodynamics Surface requirements~~ Compliance of each **Bodywork group component** with Article C3 will be assessed independently and before any **Trim and Combination** operations and **Fillet** application described in Article C3.12, and any **Aperture** application described in Article C3.16.

Compliance of the **Aerodynamic Surfaces** of each **Bodywork** component with Article C3 will be assessed independently and after their boundaries have been defined by **Trim and Combination** operations and **Fillet** application described in Article C3.12, and before any **Aperture** application described in Article C3.16.

Furthermore, the use of components not defined as **Bodywork** to achieve compliance with the **Bodywork** regulations is not permitted. The FIA may request to inspect any removed geometry post-assembly.

After final assembly, provided any modification does not result in the surfaces becoming **Aerodynamic Surfaces**, modifications are allowed to the following:

- a. Ducts (as specified in C3.1 (a) (ii) and C3.1 (a) (iii)).
- b. Non-Aerodynamic Surfaces.

C3.4.2 Wheel Bodywork

The only permissible **Wheel Bodywork** is defined in Articles C3.14 and C3.15. The Frame of Reference for all parts classified as **Wheel Bodywork** is the **Wheel Coordinate System**.

C3.4.3 Suspension Fairings

The only permissible **Suspension Fairings** are defined in Article C3.17. To assess compliance with Article C3.2.2, the Frame of Reference of any **Suspension Fairing** is the structural suspension member that it is attached to.

C3.4.4 Hanger

“**Hanger**” Bodywork, where permitted under the relevant Articles, is exempt from Article C3.2.4, but must:

- a. lie in its entirety within an individual, freely positioned instance of **RV-HANGER**.
- b. be rigidly fixed to any bodywork it intersects.
- c. within a plane, connect two non-intersecting bodywork sections.

C3.5 Floor Bodywork**C3.5.1 Floor Body**

“**Floor Body**” *Bodywork* must:

- a. lie in its entirety within **RV-FLOOR-BODY**.
- b. when viewed from below, fully obscure:
 - i. **RV-PU-ICE**.
 - ii. **RV-DIFF**.
- c. have up to two sections in any Z-Plane.

C3.5.2 Floor Foot

“**Floor Foot**” *Bodywork* must:

- a. lie in its entirety within **RV-FLOOR-FOOT**.
- b. when viewed from above, fully obscure **RS-FLOOR-FOOT**.
- c. have up to two sections in any Z-Plane.

C3.5.3 Floor Sidewall

“**Floor Sidewall**” *Bodywork* must:

- a. lie in its entirety within **RV-FLOOR-SIDEWALL**.
- b. have up to two sections in any Y-Plane.
- c. above Z = 100, have up to two sections in any Z-Plane.

C3.5.4 Main Floor

“**Main Floor**” results from the *Trim and Combination* of the following components:

- a. **Floor Body**.
- b. **Floor Foot**.
- c. **Floor Sidewall**.

A **Fillet Radius**, no greater than 30 mm, may be applied along the intersections between the remaining component parts.

Once fully defined, **Main Floor** must:

- d. be a single, simply connected volume, with no overlapping regions.
- e. be fully visible from either above or below, such that any surface obscured from one direction is visible from the other.
- f. when viewed from the side, fully obscure **RS-FLOOR-SIDEWALL**.

Main Floor Aerodynamic Surfaces must:

- g. contain no radius of curvature less than 25mm, except for regions:
 - i. within 5mm of the plan-view-boundary of **Main Floor**, when viewed from above or below.

- ii. within 45mm of a single point that lies in **RV-FLOOR-SPHERE**.
- iii. of convex curvature, visible from above, and within 10mm of the load application points defined in Article C3.18.7.
- iv. within 5mm of the **Fillet Radii** permitted as part of the **Main Floor Trim and Combination**, where the radius of curvature must be no less than 10mm.

C3.5.5 Floor Board

“Floor Board” Bodywork must:

- a. lie in its entirety within **RV-FLOOR-BOARD**.
- b. have up to three sections in any X, Y and Z-Plane.

Floor Board Aerodynamic Surfaces visible from the side must:

- c. rearward of $X_F = 825$, at any point, in any Z-Section have a:
 - i. normal with a positive X component.
 - ii. tangent that forms an angle of at least 15 degrees to the X-Axis.
- d. contain no concave radius of curvature less than 100mm.

Furthermore:

- e. compliance with (c) and (d) is not required within 35mm of up to three points, which **may must sit forward of $X_F = 1100$ and** be no closer than 50mm to each other.

C3.5.6 Floor Bib

“Floor Bib” Bodywork must:

- a. lie in its entirety within **RV-FLOOR-BIB**.
- b. be fully visible from either above or below, such that any surface obscured from one direction is visible from the other.

Floor Bib Aerodynamic Surfaces must:

- c. contain no concave radius of curvature:
 - i. visible from below.
 - ii. less than 50mm, if visible from above.

C3.5.7 Floor Leading Edge Device

“Floor Leading Edge Device” Bodywork must:

- a. lie in its entirety within **RV-FLOOR-LED**.
- b. have up to five sections in any X and Z-Plane.

Floor Leading Edge Device Aerodynamic Surfaces above $Z = 60$ must:

- c. be no less than 4mm thick (being the minimum distance when measured normal to the surface).
- d. contain no convex radius of curvature less than 2mm

C3.5.8 Floor Winglet

“**Floor Winglet**” **Bodywork**, which is exempt from Article C3.2.4, must be fitted and results from the **Trim and Combination** of the following components:

- a. **RS-FLOOR-WINGLET**.
- b. “**Winglet Profile**”, which must:
 - i. lie in its entirety within **RV-FLOOR-WINGLET**.
 - ii. contain no more than a single section in any X, Y and Z-Plane.
- c. A single **Hanger**, which must:
 - i. when viewed from below, be fully obscured by **RS-FLOOR-WINGLET**.

Furthermore, **Winglet Profile Aerodynamic Surfaces** must:

- d. contain no concave radius of curvature less than 20mm.

Once **Trimmed and Combined**, **Floor Winglet** may be further modified in the following order:

- e. Trimmed below the annotated surface ‘**TRIM-SURFACE**’ in **RS-FLOOR-WINGLET**.
- f. Rotated by ± 5 Degrees about a Y-aligned axis that passes through the point $[X_R, Z] = [295, 200]$
- g. Translated by ± 10 mm in Z.

Once fully defined, **Floor Winglet** must:

- h. have up to two sections in any Z-Plane below the annotated surface ‘**TRIM-SURFACE**’ in **RS-FLOOR-WINGLET**.
- i. lie in its entirety above $Z = 20$.

C3.5.9 Floor Fence

“**Floor Fence**” **Bodywork** must:

- a. lie in its entirety within:
 - i. an axis aligned cuboid of the following dimensions $[X, Y, Z] = [450, 40, 200]$
 - ii. **RV-FLOOR-FENCE**.
- b. be fully visible from either above or below, such that any surface obscured from one direction is visible from the other.
- c. have up to two sections in any Y-Plane.
- d. in any Z-Plane, within 150mm of the rearmost point, a line tangent to any part of the section visible from the side must not form an angle greater than 5 degrees, when measured against the X-axis.

~~Furthermore, compliance with (d) will be assessed prior to the application of any **Edge Radius** used to establish **Tangency Continuity**.~~

C3.5.10 Floor Corner

“**Floor Corner**” **Bodywork** is exempt from Article C3.2.4, but must:

- a. lie in its entirety within **RV-FLOOR-CORNER**.
- b. have up to 3 sections in any X-Plane.
- c. have up to 4 sections in any Y-Plane.
- d. have up to 2 sections in any Z-Plane.

C3.5.11 Floor Bodywork Assembly

“**Floor Bodywork Assembly**” results from the **Trim and Combination** of the following components:

- a. **Main Floor**.
- b. **Floor Bib**.
- c. **Floor Leading Edge Device**.
- d. **Floor Fence**.
- e. **Floor Board**.
- f. **Floor Winglet**.
- g. **Floor Corner**.

Before trimming, the following must be discarded:

- h. any **Floor Fence** remaining above **Main Floor**.
- i. any **Floor Board** remaining below **Main Floor**.
- j. any **Floor Winglet** remaining inboard of **Floor Sidewall**.
- k. any **Main Floor** remaining within **RV-FLOOR-CORNER**.

A **Fillet Radius**, no greater than 25mm, may be applied along the intersections between the remaining component parts.

Once fully defined, **Floor Bodywork Assembly** must:

- l. be a single volume, with no overlapping regions.
- m. when viewed from below, fully obscure **RS-FLOOR-BODY**.
- n. when viewed from below, ~~be exactly on~~ be coincident with the surfaces of **RV-FLOOR-BODY** that are visible from below and directly beneath:
 - i. **RS-FLOOR-REF**.
 - ii. **RS-FLOOR-STEP**.
- o. forward of $X_F = 1500$, when viewed from the rear, fully obscure **Floor Leading Edge Device**.
- p. when viewed from the side, fully obscure **RS-FLOOR-BOARD**.

C3.5.12 Floor Bodywork Group

Once the components defined in Articles C3.5.1 to C3.5.11 have been constructed in accordance with these provisions, including any sub-assembly operations, the resulting union is defined as “**Floor Bodywork**”.

C3.5.13 Floor Auxiliary Components

Once **Floor Bodywork** has been fully defined and **Final Assembly** in Article C3.12 completed, the following “**Floor Auxiliary Components**”, which are exempt from Article C3.2.4, may be fitted:

- a. Up to three “**Floor Body Stays**”, which may be designed to only take load in tension, and each of which must:
 - i. have a single inboard attachment location that lies between $X_F = 1775$ and $X_R = 275$.
 - ii. be fixed on its inboard end to the entirely sprung part of the car.
 - iii. be fixed on its outboard end to **Floor Bodywork**.
 - iv. have a circular cross section with a diameter no more than 5mm, except ~~for minimal details at within 45mm~~ 25mm of the inboard and outboard attachment points, or ~~for within 5mm~~ 10mm of any adjustment ~~purpose~~ mechanism.
 - v. ~~when viewed from below, be fully obscured with Floor Bodywork in place.~~
- b. Up to six **Hangers**, each of which must:
 - i. intersect **Floor Board**.
 - ii. lie no closer than 50mm to any other **Hanger**.
 - iii. when viewed from the side and below, be fully obscured with **Floor Bodywork** in place.
- c. A single “**Floor Board Brace**”, which must:
 - i. lie in its entirety within a 40mm diameter right circular cylinder and **RV-FLOOR-BRACE**.
 - ii. be rigidly fixed at its inboard end to **Forward Chassis**.
 - iii. be rigidly fixed at its outboard end to **Floor Board**.
 - iv. when viewed from the side, be fully obscured with **Floor Bodywork** in place.

Furthermore, once all **Floor Auxiliary Components** have been defined:

- d. they must be **Trimmed and Combined** with any **Bodywork** they intersect.
- e. a **Fillet Radius** no greater than 5mm, may be applied along the intersections between **Floor Auxiliary Components** and any other **Bodywork**.

C3.6 Plank and Skids**3.6.1 Plank Assembly**

A “**Plank Assembly**” must be fitted, consisting of the **Plank**, ~~wear skids, reference~~ **Skids** and mountings.

The following provisions apply to the **Plank Assembly**:

- a. The upper surface of the **Plank Assembly** must lie at $Z = 0$, so that no air can pass between it and the **Floor Body** or **Bib** lower surfaces.
- b. The geometry of the **Plank Assembly** must conform to **RV-PLANK** with a general manufacturing tolerance of $\pm 0.5\text{mm}$ when new, unless a specific dimensional tolerance is defined.

- c. The **Plank Assembly** must have three ~~50mm~~ 34mm diameter holes whose axes are parallel to the Z-axis. The centres must lie on $Y = 0$ and have X-locations $X_F = 500$, $-600 \geq X_C \geq -750$ ~~-800~~, and $470 \leq X_{PU} \leq 630$. Furthermore, the centre of the rearmost hole must lie on or ahead of $X_R = -500$.
- d. The thickness of the **Plank Assembly** measured normal to the lower surface must be $10\text{mm} \pm 0.2\text{mm}$ and must be uniform when new. A minimum thickness of 8mm will be accepted due to wear, and conformity to this provision will be checked at the peripheries of the holes required by (c) above.

Evaluation of **Skid** wear will be made by physical measurement of the **Skid** with it removed from the car. The Measurement will be made with a micrometer with a 6.35mm diameter anvil. When measured in this way, the entire periphery of each hole must be within the specified tolerance.

Four additional 10mm diameter holes are permitted provided their sole purpose is to allow access to the bolts which secure the ~~Accident Data Recorder~~ **FIA ADR** to the **Survival Cell**.

C3.6.2 Plank

The following provisions apply to the “**Plank**”:

- a. The material of the **Plank** is free, but it must be homogeneous with a specific gravity between 1.3 and 1.45, or if pocketed be made from a bonded assembly the upper 0.5mm of which must have a specific gravity of between 1.3 and 1.65 and the remainder, excluding pockets, be made from a homogeneous material with a specific gravity of between 1.3 and 1.45.
- b. The **Plank** may comprise no more than three pieces, the forward one of which may not be any less than 900mm in length.
- c. In the areas between $X_F = 630$ and $X_C = -800$ and behind $X_C = -400$, pocketing of the lower 9.5mm of the **Plank** from above is permitted. The pocket depth may not reduce the remaining **Plank** material thickness to less than ~~2mm~~ 3mm from either the lowest surface below the plane $Z=0$ when new ~~or the lower surface of any recesses necessary to fit the skids permitted by items k) to r) of this Article~~. Furthermore, the periphery of any pocket, in any horizontal plane parallel to the plane $Z=0$, must be not less than 10mm from either the edges of the **Plank** or any holes or recesses in the **Plank**. In vertical cross section the internal pocket **Fillet Radii** must be at least 3mm and in horizontal cross section 10mm. Pockets may only be filled with a material having a specific gravity of less than 0.25.

C3.6.3 ~~Wear~~ Skids

The lower surface of the **Plank** may be fitted with flush mounted ~~metal wear skids~~ **Skid** material which can only be fitted in place of plank material. “**Skids**” may only be fitted around each of the 3 holes defined in C3.6.2.c and must conform to the geometries specified below.

A metallic **Skid** is mandatory around the forward-most **Plank** hole. A metallic **Skid** is optional around the middle and rearward-most **Plank** holes. If a metallic **Skid** is not present, it may be either; replaced with a separate piece of **Plank** material, or integrated into the **Plank**. The resulting geometry must contain the hole and counterbore detail present in **RV-SKID**.

- a. The **Skid** material around the forward-most hole in the plank must:

- i. be made to the geometry defined by **RV-SKID-FWD** and associated drawing.
 - ii. be divided into three separate parts as defined in the **Reference Volume**.
 - iii. fastened directly to the Front Floor Structure with zero degrees of freedom
- b. If metallic, the **Skid** material around the central and rear-most hole in the plank must:
- i. be made to the geometry defined by **RV-SKID** and associated drawing.
 - ii. be divided into three separate parts as defined in the **Reference Volume**.
- Metallic Skids** must be made from either:
- iii. Titanium alloy **Ti6Al4V** (according to AMS4928 or AMS4911 in annealed condition); or
 - iv. 17-4PH stainless steel (to AMS 5604 / ASTM A 693 or AMS 5643/ ASTM A 564) in condition H1150 and with hardness when new less than 37 HRC.

Furthermore, they may only be machined from solid and no processes (such as forging, rolling, welding, **additional** heat treatment or coating) may be carried out either before or after machining.

The material to be used in each Competition is defined in **FIA-F1-DOC-Cxxx**.

The only permitted deviation from the specified geometry is the removal of minimum material for the fasteners.

- ~~a. May only be fitted in place of plank material.~~
- ~~b. Have a total area no greater than 10 000mm² when viewed from below. This area must be distributed, up to 8 000mm² ahead of $X_r=600$, up to 5 000mm² between $X_r=600$ and $X_e=0$ and up to 5 000mm² behind $X_e=0$~~
- ~~c. Are no greater than 4000mm² in area individually when viewed from below.~~
- ~~d. Are fitted in order that their entire lower surfaces are visible from below.~~
- ~~e. Must have a minimum cross-sectional thickness of 15mm across its external boundaries in plan view.~~
- ~~f. The minimum wall thickness between an internal fixing hole, including any counterbore or countersink, and the external boundaries of the Wear Skid must be no less than 5mm.~~
- ~~g. Must have an upper surface no lower than $Z=3$.~~
- ~~h. Must be designed such that they are secured to the car using the fasteners described in Article C3.6.5 and that, when viewed from below, no part of the skid is more than 50mm from the centre line of a fastener which passes through that skid.~~
- ~~i. Must be made from Titanium alloy (according to AMS4928 or AMS4911 in annealed condition). Furthermore, they may only be machined from solid and no processes (such as forging, rolling, welding, heat treatment or coating) may be carried out either before or after machining.~~
- ~~j. If positioned entirely inboard of $Y=120$ and between $X_r=425$ and $X_r=625$, must be fastened directly to the Front Floor Structure with zero degrees of freedom.~~

~~C3.6.4 Reference skids~~

~~The three holes within the plank assembly, as defined in C3.6.1.c, must contain reference skids for the purpose of measuring the wear of the plank assembly which:~~

- ~~a. Arc fitted in order that their entire lower surfaces are visible from below;~~
- ~~b. Must be fitted such that their entire upper surface lies on Z=0;~~
- ~~c. Must have a diameter of 44±2mm and be concentric with the holes in the plank assembly;~~
- ~~d. Must have a minimum wall thickness between an internal fixing hole, including any counterbore or countersink, and the external boundaries of the skid of no less than 4mm;~~
- ~~e. Must be made from Titanium alloy (according to AMS4928 or AMS4911 in annealed condition). Furthermore, they may only be machined from solid and no processes (such as forging, rolling, welding, heat treatment or coating) may be carried out either before or after machining;~~
- ~~f. Must have a 12mm diameter counterbore to a depth of 3mm into the lower face when new, for inspecting the reference skid wear;~~
- ~~g. Must have a 6mm diameter through hole, for measuring the Z=0 plane;~~
- ~~h. Must have a thickness between 9mm and 10mm for the Reference Skid Positioned at X_r=500, and between 8mm and 8.5mm for the other 2 Reference Skids;~~

~~For the avoidance of doubt, the counterbore into lower surface of the reference skid defined in C3.6.4f will only be used as an indicator of skid wear. The final check of skid wear and compliance with C3.6.4h will be done by physical measurement of the reference skid with it removed from the car. The Measurement will be made with a micrometer with a 6.35mm diameter anvil. When measured in this way, the entire surface of the Wear Skid must be within the specified tolerance.~~

C3.6.4 Plank and Skid Mountings

The **Plank**, ~~Wear Skids~~, and **Reference Skids** must be fixed to the car using fasteners which are no smaller than M6 and are made from grade 12.9 or 10.9 steel.

- ~~a. Are no smaller than M6 and are made from grade 12.9 or 10.9 steel;~~
- ~~b. If used to attach a skid to the car, must employ at least 1 fastener per 1,000mm² of skid area;~~
- ~~c. If used to attach a skid to the car, the team must be able to show by calculation that the shanks of the fasteners (which may be no less than 6mm diameter) are the weakest point in the attachment of the skids to the car;~~
- ~~d. May use a load spreading washer if required;~~

~~The total area of the fasteners and any load spreading washers employed with them when viewed from below must be less than 7,500mm². The area of any single fastener plus its load spreading washer may not exceed 500mm².~~

~~No part of any fastener or load spreading washer may be lower than Z=8 mm if used to attach the skids referred to in Article C3.6.3 or lower than Z=6 if used to attach the skids referred to in Article C3.6.4. For the avoidance of doubt, the skids referred to in Articles C3.6.3 and C3.6.4 will not be treated as load spreading washers.~~

If used to attach a **Skid** to the car, the number of fixings for each type of **Skid** is defined as follows:

- a. **RV-SKID-FWD**: three fixings in each of the two forwardmost resulting **Skids** and two fixings for the rearward most resulting **Skid**.
- b. **RV-SKID**: two fixings in each of the resulting **Skids**.
- c. when viewed from below, no part of the **Skid** can be more than 50mm from the centre line of a fastener which passes through that **Skid**.
- d. the minimum wall thickness between an internal fixing hole, including any counterbore or countersink, and the external boundaries of the **Skid** must be no less than 5mm.

If used to attach the **Plank** to the car:

- e. May use a load spreading washer if required.
- f. the area of any single fastener plus its load-spreading washer may not exceed 500mm².
- g. no part of any load-spreading washer may be below Z = -7. The **Skids** referred to in C3.6.3 are not considered as load spreading washers.

The following provisions apply to each single fastener

- h. the shanks of the fasteners (which may be no less than 6mm diameter) must be the weakest point in the attachment of the **Skids** to the car.
- i. no part of any fastener may be below Z = -7.5.

C3.7 Front Bodywork

C3.7.1 Nose

“Nose” Bodywork must:

- a. lie in its entirety within **RV-NOSE**.
- b. when viewed from above, fully obscure **RS-NOSE** ahead of $X_A = 0$.

Nose Aerodynamic Surfaces, must be **Tangent Continuous**, and in any X-Plane must:

- c. contain no concave radius of curvature.
- d. between $X_F = -950$ and $X_A = 0$, have a section that when viewed from above:
 - i. is tangent to the Z-Axis at its outermost extremity.
 - ii. contains no radius of curvature less than 45mm at $X_A = 0$.
 - iii. contains no radius of curvature less than 20mm forward of $X_A = 0$.

Furthermore, the following will be exempt from the above:

- e. Cameras in Position 2.
- f. Mounting brackets defined in Article C8.16.7.

C3.7.2 Forward Chassis

“Forward Chassis” Bodywork must:

- a. lie in its entirety within **RV-CH-FRONT**.
- b. **completely fully** enclose **RV-CH-FRONT-MIN**.

- c. have up to two sections in any Z-Plane.

Forward Chassis Aerodynamic Surfaces, in any X-Plane, must contain:

- d. no convex radius less than 45mm.
- e. no concave radius less than 500mm.

C3.7.3 Mid Chassis

“Mid Chassis” Bodywork must:

- a. lie in its entirety within **RV-CH-MID**.
- b. have up to two sections in any Z-Plane.

Mid Chassis Aerodynamic Surfaces must contain:

- c. no concave radius of curvature less than 50mm, except for regions within:
 - i. 50mm of the **Secondary Roll Structure** ~~as defined in Article C12.4.2.~~
 - ii. 25mm of the **Aperture** defined in Article C3.16.810.
- d. no convex radius of curvature less than 25mm below Z = 200.

C3.7.4 Roll Hoop

“Roll Hoop” Bodywork is exempt from Article C3.2.4, but must:

- a. lie in its entirety within **RV-ROLL-HOOP**.

C3.7.5 Mirror

“Mirror Body” Bodywork must:

- a. lie in its entirety within **RV-MIRROR-BODY**.
- b. fully enclose an individual instance of **RV-LATERAL-SAFETY-LIGHT** which may be freely translated along any axis, and rotated up to +/-5deg about any Z-axis only.
- c. have an external surface coincident with the highlighted surface of **RV-LATERAL-SAFETY-LIGHT**.

“Mirror Inner Stay” Bodywork must:

- d. lie in its entirety within **RV-MIRROR-ISTAY**.
- e. intersect **Mirror Body** and **Mid Chassis**.

“Mirror Rear Stay” bodywork must:

- f. lie in its entirety within **RV-MIRROR-RSTAY**.
- g. intersect **Mirror Body** and **Sidepod**.
- h. in any X-Plane, measure less than:
 - i. 50mm in Z.
 - ii. 10mm in Y.

“Mirror” results from the Trim and Combination of the following components:

- i. **Mirror Body.**
- j. **Mirror Inner Stay.**
- k. **Mirror Rear Stay.**

A **Fillet Radius**, no greater than 10mm, may be applied along the intersections between the remaining component parts.

Once fully defined, **Mirror** must:

- l. be a single volume with no overlapping regions.

C3.7.6 Driver Cooling

“**Driver Cooling**” **Bodywork** must:

- a. lie in its entirety within **RV-DRI-COOL**.
- b. be fully visible from either above or below, such that any surface obscured from one direction is visible from the other.

Driver Cooling Aerodynamic Surfaces must:

- c. contain no radius of curvature less than 10mm.

C3.7.7 Front Bodywork Assembly

“**Front Bodywork Assembly**” results from the **Trim and Combination** of the following components:

- a. **Nose.**
- b. **Forward Chassis.**
- c. **Mid Chassis.**
- d. **Roll Hoop.**
- e. **Mirror.**
- f. **Driver Cooling**, if present.

A **Fillet Radius**, no greater than ~~10mm~~ **15mm**, may be applied along the intersections between the remaining component parts.

Once fully defined, **Front Bodywork Assembly** must:

- g. be a single volume, with no overlapping regions.

C3.7.8 Front Bodywork Group

Once the components defined in Articles C3.7.1 to C3.7.7 have been constructed in accordance with these provisions, including any sub-assembly operations, the resulting union is defined as “**Front Bodywork**”.

C3.8 Rear Bodywork

C3.8.1 Sidepod

“**Sidepod**” **Bodywork** must:

- a. lie in its entirety:
 - i. within **RV-SIDEPOD**.
 - ii. ~~in its entirety, lie~~ more than 50mm from **Floor Board**.

Sidepod Aerodynamic Surfaces must contain:

~~b. contain no radius of curvature less than:~~

- ~~i. 50mm in a convex direction;~~
- ~~ii. 100mm in a concave direction;~~

- b. no convex radius less than 50mm.
- c. no concave radius less than 100mm.

Furthermore, compliance with:

- d. (b) and (c) is not required within 20mm of the upper **Side Impact Structure**, ~~defined in Article C13.5.1~~, where the radius of curvature must not be less than 10mm.
- e. (b) ~~(c)~~ is not required within 25mm of the Aperture C3.16.79.

c3.8.2 Engine Cover

“**Engine Cover**” **Bodywork** must:

- a. lie in its entirety within **RV-EC**.
- b. have up to two sections in any Z-Plane.
- c. when viewed from the side, fully obscure **RS-EC**.

Engine Cover Aerodynamic Surfaces, in any X-Plane outboard of $Y = 5$, must contain:

- d. no convex radius of curvature less than 75mm.
- e. no concave radius of curvature less than 50mm.

Furthermore, when considering **Aerodynamic Surfaces** only:

- f. compliance with (d) and (e) is not required:
 - i. within 20mm of the upper and lower **Side Impact Structures**, ~~defined in Article C13.5.1~~, where the radius of curvature, ~~measured independent of direction~~, must not be less than 10mm.
 - ii. inboard of $Y = 25$, where the radius of curvature, ~~in any X-Plane~~, must not be less than 25mm.
- g. rearward of $X_R = -300$ and below $Z = 350$, the X component of any normal to the surface visible from the side must not be negative.
- h. there must be no ~~Aerodynamic Surfaces~~ surface parallel to an X-Plane ahead of $X_R = -55$.

c3.8.3 Rear Bodywork Assembly

“**Rear Bodywork Assembly**” results from the **Trim and Combination** of the following components:

- a. **Sidepod**.

b. **Engine Cover.**

Once fully defined, **Rear Bodywork Assembly** must:

- c. be a single, simply connected volume, with no overlapping regions.

C3.8.4 Rear Bodywork Group

Once the components defined in Articles C3.8.1 to C3.8.3 have been constructed in accordance with these provisions, including any sub-assembly operations, the resulting union is defined as “**Rear Bodywork**”.

C3.9 Tail and Exhaust Tailpipe**C3.9.1 Tail**

“**Tail**” **Bodywork** must:

- a. lie in its entirety within **RV-TAIL**.
- b. when viewed from below, be fully obscured by **Floor Body** forward of $X_R = 295$.
- c. below $Z = 300$ ~~450~~, have up to ~~two~~ **three** sections in any Z-Plane.

C3.9.2 Exhaust Tailpipe

“**Exhaust Tailpipe**” **Bodywork** is exempt from Article C3.2.4 (a), but rearwards of $X_R = -55$ must:

- a. lie in its entirety within **RV-TAILPIPE**.
- b. have up to two sections in any Y and Z-Plane.
- c. have a wall thickness of between 0.5mm and 1.2mm.
- d. have an exit whose entire circumference lies:
 - i. between $X_R = 390$ and $X_R = 400$.
 - ii. above $Z = 350$.
- e. over its last 370mm, have a circular internal cross-section of a constant diameter between 90mm and 130mm.
- f. remain unobstructed internally and in full compliance with the provisions of this Article after Final Assembly of all **Bodywork** groups and application of **Apertures**.

When considering both sides of the car, over its last 150mm it must:

- g. comprise of a single tailpipe and a support.
 - i. The support must lie in its entirety within an individual instance of **RV-TAILPIPE-BRACKET**.
 - ii. **RV-TAILPIPE-BRACKET** may have a free orientation in space but must intersect both **Exhaust Tailpipe** and **Tail**.
- h. have an internal surface which is a right circular cylinder and has a single axis that:
 - i. lies on $Y = 0$.
 - ii. forms an angle between 0.0 and 2.5° to the X-Axis.

C3.10 Front Wing (FW)**C3.10.1 Front Wing Profiles**

“**Front Wing Profiles**” **Bodywork** is exempt from C3.2.4 (b) but must:

- a. lie in its entirety within **RV-FW-PROFILES**.
- b. comprise of up to three, non-intersecting, simply connected volumes.
- c. have up to three sections in any Y-Plane.
- d. when viewed from above, fully obscure **RS-FW-PROFILES**.

In any Y-Plane:

- e. the rearmost point of every section must be visible when viewed from below.
- f. except for the rearmost section, the rearmost point of every section must not be visible when viewed from above.
- g. assessing each section independently, within 40mm of the rearmost point of each section:
 - i. a line tangent to any part of the section visible from below must have a positive slope. The slope of this line will be considered in the Y-Plane.
 - ii. no part of the section visible from above may be more than 10mm distant from the section visible from below, if outboard of $Y = 400$, or 15mm if inboard of $Y = 400$.

~~Front Wing Profiles Aerodynamic Surfaces must:~~

- h. ~~in any Y-Plane~~ contain:
 - i. no concave radius of curvature visible from below.
 - ii. no concave radius of curvature less than 50mm visible from above.

Furthermore:

- i. when measured against a vertical plane normal to **RS-FW-SECTION**, contain no normal to any point on the surface that subtends an angle greater than 30° .

Furthermore:

- j. compliance with (i) is not required for surfaces that lie exactly on $Y = 0$ or $Y = 675$.
- k. outboard of $Y = 475$, compliance with (h) and (i) is not required within 15mm of **FW SLM Linkage**, provided the linkage lies in its entirety within **Front Wing Bodywork Profiles** or **Front Wing Endplate**.
- l. At all points along the span, the minimum distance between adjacent **Front Wing Profiles** volumes must be between 5mm and 15mm when measured with a spherical gauge.
- m. The rearmost point of every individual Y-section, when projected in Z onto a plane through $Z = 0$, must produce a single tangent continuous curve with no radius of curvature less than 200mm.

Once the **Front Wing Profiles** ~~are~~ **bodywork** is fully defined, **Gurneys** up to 10mm in height may be fitted to the trailing edge of the upper surface of the rearmost section. These **Gurneys** are considered to be part of the **Front Wing Profiles** and must satisfy the provisions of this Article

except for (g) and (h) and, for the inner extremity of the innermost **Gurney** and outer extremity of the outermost **Gurney**, (i).

C3.10.2 Front Wing Endplate Body

“**Front Wing Endplate Body**” **Bodywork** must:

- a. lie in its entirety within **RV-FWEP-BODY**.
- b. have up to two sections in any Y-Plane.

Front Wing Endplate Body Aerodynamic Surfaces must contain:

- c. no convex radius of curvature less than 5mm.
- d. no concave radius of curvature less than 100mm.

C3.10.3 Front Wing Outboard Footplate

“**Front Wing Outboard Footplate**” **Bodywork** must:

- a. lie in its entirety within **RV-FWEP-OFP**.
- b. below $Z = 160$, have up to two sections in any Z-Plane.
- c. rearwards of $X_F = -425$, have up to two sections in any X-Plane.

Front Wing Outboard Footplate Aerodynamic Surfaces must contain:

- d. no radius of curvature less than 5mm.
- e. no concave radius of curvature less than 50mm visible from below.
- f. no concave radius of curvature less than 50mm outboard of $Y = 825$ mm.

C3.10.4 Front Wing Inboard Footplate

“**Front Wing Inboard Footplate**” **Bodywork** must:

- a. lie in its entirety within **RV-FWEP-IFP**.

C3.10.5 Front Wing Endplate Diveplane

“**Front Wing Endplate Diveplane**” **Bodywork** must:

- a. lie in its entirety within:
 - i. an axis aligned cuboid of the following dimensions $[X, Y, Z] = [300, 325, 50]$.
 - ii. **RV-FWEP-DIVEPLANE**.

Front Wing Endplate Diveplane Aerodynamic Surfaces must contain:

- b. no convex radius of curvature less than 5mm.
- c. no concave radius of curvature less than 50mm.

C3.10.6 Front Wing Endplate

“**Front Wing Endplate**” results from the **Trim and Combination** of the following components:

- a. **Front Wing Endplate Body**.
- b. **Front Wing Outboard Footplate**.

- c. **Front Wing Inboard Footplate.**
- d. **Front Wing Endplate Diveplane, if fitted.**

Before trimming, any **Front Wing Endplate Body** remaining below **Front Wing Inboard Footplate** must be discarded.

A **Fillet Radius**, no greater than 40mm, may be applied along the intersections between **Front Wing Endplate Body** and **Front Wing Diveplane**. A **Fillet Radius**, no greater than 10mm, may be applied along the intersections between the remaining component parts.

Once fully defined, **Front Wing Endplate** must:

- e. be a single, simply connected volume, with no overlapping regions.
- f. be no less than 10mm thick (being the minimum distance when measured normal to the surface), if visible from the side.
- g. when viewed from above, fully obscure **RS-FWEP-TOP**:
- h. when viewed parallel to the Y-Axis from inboard, fully obscure **RS-FWEP-SIDE** and **Front Wing Endplate Diveplane**.

C3.10.7 Front Wing Pylon

“Front Wing Pylon” **Bodywork** must:

- a. lie in its entirety within **RV-FW-PYLON**.
- b. in any Z-Plane:
 - i. have a total area no greater than 6000 mm².
 - ii. measure no more than 35mm in the Y direction.

C3.10.8 Front Wing Strake

“Front Wing Strake” **Bodywork** must:

- a. lie in its entirety within:
 - i. an axis aligned cuboid of the following dimensions [X, Y, Z] = [775, 20, 100].
 - ii. **RV-FW-STRAKE**.
- b. have up to two sections in any Y or Z-Plane.

C3.10.9 Front Wing Assembly

“Front Wing Assembly” results from the **Trim and Combination** of the following components:

- a. **Front Wing Profiles.**
- b. **Front Wing Endplate.**
- c. **Front Wing Pylon.**
- d. **Front Wing Strake, if fitted.**

Before trimming is applied, any **Front Wing Profiles** remaining outboard of **Front Wing Endplate** and any **Front Wing Pylon** remaining below **Front Wing Profiles** must be discarded.

A **Fillet Radius**, no greater than 10mm, may be applied along the intersections between the remaining component parts.

Once fully defined, **Front Wing Assembly** must:

- e. be a single volume, with no overlapping regions.
- f. when viewed from below, fully obscure **Front Wing Pylon**.
- g. when viewed from above, fully obscure **Front Wing Strake** forward of $X_F = -715$, if fitted.

C3.10.10 Front Wing Adjustment Adjuster System

The “**Front Wing Adjuster System**” is defined as follows:

- a. “**FW Primary Flap**”, if fitted, must:
 - i. be a continuous portion of ~~only the two rearmost volumes of~~ **Front Wing Profiles**, excluding the forwardmost volume.
 - ii. rotate about the “**Primary Axis**”, which must pass through **Point A** and **Point B** and be fixed relative to the forwardmost volume of **Front Wing Profiles**.
- b. “**FW Secondary Flap**”, if fitted, must:
 - i. be a continuous portion of only the rearmost volume of **Front Wing Profiles**.
 - ii. rotate about the “**Secondary Axis**”, which must pass through **Point C** and **Point D** and be fixed relative to either the **Primary Flap** if fitted, or the forwardmost volume of **Front Wing Profiles**.
- c. Both **FW Primary Flap** and **FW Secondary Flap** may include any fitted **Gurneys** and any parts of **Front Wing Auxiliary Components** that are attached to the respective volumes.
- d. “**Point A**” and “**Point B**” must lie:
 - i. within the volume of **FW Primary Flap**.
 - ii. no more than 25mm from the forwardmost point of **FW Primary Flap** at their respective Y positions.
- e. “**Point C**” and “**Point D**” must lie:
 - i. within the volume of **FW Secondary Flap**.
 - ii. no more than 25mm from the forwardmost point of **FW Secondary Flap** at their respective Y positions.
- f. **Point A** and **Point C** must lie inboard of $Y = 150$.
- g. **Point B** and **Point D** must lie between $Y = 475$ and $Y = 675$.

With **Front Wing Profiles** positioned to comply with Article C3.10.1, up to two pairs of rotation surfaces (four in total) must be defined as follows:

- h. “**Primary Rotation Surfaces**”, which must:
 - i. use the **Primary Axis** as their axis of revolution.
 - ii. pass through **Point A** for the first surface and **Point B** for the second surface.

- iii. extend over the complete chord of **FW Primary Flap**.
- i. “**Secondary Rotation Surfaces**”, which must:
 - i. use the **Secondary Axis** as their axis of revolution.
 - ii. pass through **Point C** for the third surface and **Point D** for the fourth surface.
 - iii. extend over the complete chord of **FW Secondary Flap**.
- j. No surface of rotation may have a normal which forms an angle greater than 30 degrees to the Y-Axis.

Compared to the position of **Front Wing Profiles** defined in Article C3.10.1, adjustment not controlled by the **FIA Standard ECU** must:

- k. not result in a decrease in incidence of the tangent lines defined in Article C3.10.1 (g) (i).
- l. result in a maximum deviation for any point of **Front Wing Profiles** no greater than:
 - i. 30mm for **FW Primary Flap**.
 - ii. 60mm for **FW Secondary Flap**.

Any adjustment of **Front Wing Profiles** controlled by the FIA Standard ECU must:

- m. be about one of the **Primary Axis** or **Secondary Axis** only.
- n. when commanded, switch to one of two fixed positions defined as follows:
 - i. a “**Corner Mode**” position, that conforms to a position defined in (k) and that remains identical following any **Straight-Line Mode** operation to its position beforehand.
 - ii. a “**Straight-Line Mode**” position that, when compared to the **Corner Mode** position, results in a decrease in incidence of **FW Primary Flap** and/or **FW Secondary Flap**. Furthermore, except when limited by a physical stop defined in (t), the magnitude of decrease must always remain identical.
- o. have a maximum transition time between the two fixed positions that does not exceed ~~600~~ 400ms.
- p. be driven by up to two actuators, across both sides of the car, which may be electrical or fluidic.
 - ~~i. must be equipped with a position sensor with an analogue output calibrated over the actuator travel that measures its position and is connected to the FIA Standard ECU as specified by the FIA.~~
 - ~~ii. may be electrical or fluidic.~~
- q. be measured by position sensors, one for each of the actuators defined in (p), which:
 - i. are mechanically linked to **Front Wing Profiles**.
 - ii. output analogue signals calibrated over the actuator travel.
 - iii. are connected to the **FIA Standard ECU** as specified by the FIA.
- ~~q. compared to Front Wing Profiles in Corner Mode, result in a maximum deviation for any point of Front Wing Profiles no greater than 120mm.~~

- r. be symmetrical about Y=0.

Furthermore:

- s. ~~Any~~ Irrespective of whether the adjustment is controlled by the **FIA Standard ECU**, ~~of any fitted~~ **FW Primary Flap** ~~or~~ and **FW Secondary Flap** must ~~maintain~~:
 - i. remain in their entirety within **RV-FW-PROFILES**.
 - ii. retain the geometric relationship between all ~~parts of within~~ elements of **FW Primary Flap** and **FW Secondary Flap**.
 - iii. retain the geometric relationship between all elements of **FW Secondary Flap**.
 - iv. ~~compliance~~ conform with all bodywork regulations except for Article C3.2.4 (b), Article 3.10.11 (g) (i) and sub-clauses (b) to ~~(g)~~ (m) of Article C3.10.1.
- t. Except for a failure of the **Front Wing Adjuster System**, or during the transition between **Corner Mode** and **Straight-Line Mode**, **FW Primary Flap** and **FW Secondary Flap** can only have the two positions defined in (n).
- u. Physical stops must be provided to prevent both ~~the~~ **FW Primary Flap** and ~~the~~ **FW Secondary Flap** from being rotated ~~beyond the limits defined in (l) and (q)~~ external to **RV-FW-PROFILES**.
- v. The design is such that failure of the system will result in it returning to its **Corner Mode** position.
- ~~v. Any adjustment permitted under this Article is only allowed when the car is stationary or when specifically permitted by Article B7.~~
- w. **FW Primary Flap** and **FW Secondary Flap** may only be in a **State of Deployment** when the car is stationary or fully inside an **Activation Zone** as defined by Article B7.1.1 (d).

C3.10.11 Front Wing Auxiliary Components

Once **Front Wing Assembly** has been fully defined, the following “**Front Wing Auxiliary Components**”, which, ~~unless otherwise stated~~, are exempt from Article C3.2.4, may be fitted:

- a. In order to ensure the necessary level of sealing, ~~Up~~ up to four sets of “**Front Wing Fishplates**”, each of which must:
 - i. lie in its entirety within 3mm of a **Primary or Secondary Rotation Surface** ~~defined in Article C3.10.10 (h) and (i)~~.
 - ii. not exceed the size necessary to allow 20mm of overlap between the adjustable and non-adjustable parts of **Front Wing Profiles**, throughout the range of deviation defined in C3.10.10 (l).
- b. Up to eight **Hangers**, each of which must:
 - i. intersect two adjacent volumes of **Front Wing Profiles**.
 - ii. be no closer than 150mm to any other **Hanger** that intersects the same two volumes of **Front Wing Profiles**.
- c. Up to three “**Front Wing Rotation Brackets**”, for each of **FW Primary Flap** and **FW Secondary Flap**, each of which must:

- i. lie in its entirety within an individual, freely positioned instance of **RV-HANGER**.
 - ii. intersect either the **Primary Axis** or the **Secondary Axis**.
- d. A single “**FW SLM Adjuster CL Fairing**”, ~~which, that may only be fitted to enclose the actuator defined in Article C3.10.10 (p), and~~ which must comply with Article C3.2.4 and:
- i. lie in its entirety within **RV-FW-SLM-CL-FAIRING**.
 - ii. have up to two sections in any Y-Plane.
- e. A single “**FW SLM Mid Fairing**”, that may only be fitted to enclose the actuator defined in Article C3.10.10 (p), and must:
- i. lie in its entirety within both an axis aligned cuboid of the following dimensions [X, Y, Z] = [250, 50, 100] and **RV-FW-SLM-MID**.
 - ii. comply with Article C3.2.4.
 - iii. be no less than 25mm thick (being the minimum distance when measured normal to the surface).
 - iv. contain no radius of curvature less than 5mm.
- f. A single “**FW SLM MID Pillar**”, that may only be fitted alongside **FW SLM Mid Fairing**, and must:
- i. lie in its entirety within both an axis aligned cuboid of the following dimensions [X, Y, Z] = [250, 50, 100] and **RV-FW-SLM-MID**.
 - ii. comply with Article C3.2.4.
 - iii. be arranged such that it is not visible from above with **FW SLM Mid Fairing** in place.
- g. A single “**FW SLM Linkage**” which must:
- i. lie in its entirety within an individual, freely positioned instance of **RV-FW-SLM-LINKAGE**.
 - ii. intersect both **Front Wing Profiles** and one of **Nose**, **FW SLM Mid Fairing** or **Front Wing Endplate Body**.
 - iii. if outboard of Y = 450, lie in its entirety within **Front Wing Bodywork**.
 - iv. if inboard of Y = 200, be fully obscured from above with **Nose** present.
- h. A single “**Front Wing Adjuster Fairing**” which must:
- i. lie in its entirety within an individual, freely positioned instance of **RV-FW-ADJUSTER**.
 - ii. intersect for the entire range of adjustment, the adjustable part of **Front Wing Profiles** not controlled by the **FIA Standard ECU** and the part of **Front Wing Profiles** that is either stationary or controlled by the **FIA Standard ECU**.
- i. A single “**Tyre Temperature Fairing**” which must:
- i. lie in its entirety within an individual, freely positioned instance of **RV-FW-SENSOR**.
 - ii. intersect either **Front Wing Profiles** or **Front Wing Endplate**.
 - iii. lie in its entirety below Z = 350.

Furthermore, once all **Front Wing Auxiliary Components** have been defined:

- j. they must be **Trimmed and Combined** with **themselves, Front Wing Assembly** or **Nose**.
- k. a **Fillet Radius** no greater than 10mm, may be applied along the intersection between **FW SLM CL Fairing** and **Nose**. Fillet radii, no greater than 4mm, may be applied along the intersections between all remaining **Front Wing Auxiliary Components** and **Front Wing Assembly**.
- l. the total of **Hangers** plus **Front Wing Rotation Brackets** fitted to **Front Wing Assembly** must not exceed ten.
- m. except for **FW SLM Adjuster CL Fairing** and **Front Wing Fishplates**, **they Front Wing Auxiliary Components** must be arranged such that they are not visible from below with **Front Wing Assembly** in place.
- n. **Aerodynamic Flexible Seals** ~~must~~ may be fitted between the adjustable and non-adjustable parts of **Front Wing Assembly**, covering the full range of deviation defined in Article C3.10.10.l.

C3.10.12 Front Wing Bodywork Group

Once the components defined in Articles C3.10.1 to C3.10.11 have been constructed in accordance with these provisions, including any subassembly operations, the resulting union is defined as **“Front Wing Bodywork”**.

C3.11 Rear Wing (RW)

C3.11.1 Rear Wing Profiles

“Rear Wing Profiles” Bodywork must:

- a. lie in its entirety within **RV-RW-PROFILES**.
- b. comprise of up to three, non-intersecting, simply connected volumes.
- c. when assessing each volume independently, contain no more than two sections in any Z-Plane and a single section in any X and Y -Plane.
- d. in any Y-Plane, within 40mm of the rearmost point of the forwardmost section, a line tangent to any part of the section visible from below, must not form an angle greater than 10 degrees when measured against the X-axis.

~~Rear Wing Profiles Aerodynamic Surfaces must:~~

- e. in any Y-Plane, contain:
 - i. no concave radius of curvature visible from below.
 - ii. no concave radius of curvature less than 100mm visible from above.

Furthermore, ~~when considering Aerodynamic Surfaces only:~~

- f. when measured against a Y-Plane, contain no normal to any point on the surface that subtends an angle greater than 20°.
 - i. **compliance with (f) is not required for surfaces that lie exactly on Y = 0 or Y = 575.**
- g. at all points along the span, the minimum distance between adjacent **Rear Wing Profiles** volumes must be between 8mm and 12mm and will be measured with a spherical gauge.

Furthermore:

Once the **Rear Wing Profiles** are fully defined, a **Gurney** of up to 10mm may be fitted to the trailing edge of the upper surface of the rearmost section. This **Gurney** is considered part of the Rear Wing Profiles and must satisfy the provisions of this Article except for (c), ~~(e)~~ (e) and ~~(f)~~ (f).

C3.11.2 Rear Wing Endplate Body

“Rear Wing Endplate Body” **Bodywork** must:

- a. lie in its entirety within **RV-RWEP-BODY**.
- b. have up to two sections in any Y-Plane
- c. when viewed from the side, fully obscure **RS-RWEP**.

Rear Wing Endplate Body Aerodynamic Surfaces must:

- d. contain no concave radius of curvature less than 100mm.

C3.11.3 Rear Wing Brace

“Rear Wing Brace” **Bodywork** must:

- a. lie in its entirety within:
 - i. an axis aligned cuboid of the following dimensions [X, Y, Z] = [100, 375, 40].
 - ii. **RV-RW-BRACE**.
- b. in any Y Plane:
 - i. have at least one axis of symmetry where the larger one will be called the ‘major axis’.
 - ii. have no dimension which exceeds 5mm larger than the major axis.

~~in any Y Plane:~~

~~b. have at least one axis of symmetry:~~

- c. contain no concave radius of curvature less than 100mm.

C3.11.4 Rear Wing Pylon

“Rear Wing Pylon” **Bodywork** must:

- a. lie in its entirety within **RV-RW-PYLON**.
- b. in any Z-Plane:
 - i. have a total area no greater than 5000 mm², except for regions within 30mm of **Exhaust Tailpipe**.
 - ii. measure less than 25mm in the Y direction, except for regions inside of **RV-TAILPIPE**.

Furthermore:

- c. no part of **Rear Wing Profiles** may be obscured by ~~Rear Wing Profiles~~ **Rear Wing Pylon** when viewed from above.

C3.11.5 Rear Wing Assembly

“**Rear Wing Assembly**” results from the **Trim and Combination** of the following components:

- a. **Rear Wing Profiles.**
- b. **Rear Wing Endplate Body.**
- c. **Rear Wing Brace.**
- d. **Rear Wing Pylon.**

Before trimming is applied, any **Rear Wing Profiles** and **Rear Wing Brace** remaining outboard of **Rear Wing Endplate Body** must be discarded.

A **Fillet Radius**, no greater than 10mm, may be applied along the intersections between the remaining component parts.

Once fully defined, **Rear Wing Assembly** must:

- e. be a single volume, with no overlapping regions.

C3.11.6 Rear Wing Adjuster System

The “**Rear Wing Adjuster System**” is defined as follows:

- a. “**RW Flap**” is constructed solely from **Rear Wing Profiles** and must:
 - i. exclude all the forwardmost volume.
 - ii. exclude all remaining volumes outboard of $Y = 535$.
 - iii. include all remaining volumes inboard of $Y = 530$.
 - iv. include any fitted **Gurney** and any parts of **Rear Wing Auxiliary Components** that are attached to any included volumes.
- b. Adjustment of **RW Flap** is about a fixed axis of rotation which must:
 - i. be aligned with a Y-Axis.
 - ii. lie within **RV-RW-PROFILES**.
 - iii. at $Y = 0$, lie between the rearmost point and the mid-point of **RW Flap**, measured in the X-direction.
 - iv. inboard of $Y = 535$, when viewed from below, be fully obscured by **RW Flap**.

Any adjustment of **RW Flap** may only be controlled by the FIA Standard ECU and must:

- c. when commanded, switch to one of two fixed positions defined as follows:
 - i. a “**Corner Mode**” position, that exactly conforms to the position of **Rear Wing Profiles** defined in Article C3.11.1 and that remains identical following any **Straight-Line Mode** operation to its position beforehand.
 - ii. a “**Straight-Line Mode**” position that, when compared to the **Corner Mode** position, results in a decrease in incidence of **RW Flap**. **Furthermore, the magnitude of decrease must always remain identical.**

- d. have a maximum transition time between the two fixed positions that does not exceed ~~600~~400ms.
- e. be driven by a single actuator which may be electrical or fluidic.
 - ~~i. must be equipped with a position sensor with an analogue output calibrated over the actuator travel that measures its position and is connected to the FIA Standard ECU as specified by the FIA.~~
 - ~~ii. may be electrical or fluidic.~~
- f. be measured by a position sensor which:
 - i. is mechanically linked to the **RW Flap**.
 - ii. outputs analogue signals calibrated over the actuator travel.
 - iii. is connected to the **FIA Standard ECU** as specified by the FIA.

Furthermore:

- f. Any adjustment of **RW Flap** must maintain:
 - i. the geometric relationship between all parts of **RW Flap**.
 - ii. compliance with all bodywork regulations except for Article C3.11.1.
- g. Except for a failure of the **Rear Wing Adjuster System**, or during the transition between **Corner Mode** and **Straight-Line Mode**, **RW Flap** can only have the two positions defined in (c).
- h. The design is such that failure of the system will result in **RW Flap** returning to its **Corner Mode** position.
 - ~~i. Any adjustment permitted under this Article is only allowed when specifically permitted by Article B7.1.~~
 - i. **RW Flap** may only be in a **State of Deployment** when the car is stationary or fully inside an **Activation Zone** as defined by Article B7.1.1 (d).
- j. Physical stops must be provided to prevent **RW Flap** from being rotated beyond these limits.

C3.11.7 Rear Wing Auxiliary Components

Once **Rear Wing Assembly** has been fully defined, the following “**Rear Wing Auxiliary Components**”, which are exempt from Article C3.2.4, may be fitted:

- a. When **RW Flap** has two volumes, up to four **Hangers**, each of which must:
 - i. intersect both volumes of **RW Flap**.
 - ii. be no closer than 140mm to any other **Hanger**.
- b. Up to five pairs of “**Rear Wing Separators**”, across both sides of the car, where between three and five pairs must be fitted and each pair must:
 - i. lie in its entirety within an individual, freely positioned instance of **RV-RW-SEPARATOR**.
 - ii. intersect both the forwardmost volume of **Rear Wing Profiles** and **RW Flap**.
 - iii. be no closer than 200mm to any other **Rear Wing Separator**.

- iv. be designed and arranged such that the relationship between volumes of **Rear Wing Profiles** can only change whilst the car is in motion in accordance to Article C3.11.6.
- v. be aligned to provide a bearing across at least 40mm² when the distance between **Rear Wing Profiles** and **RW Flap** is at its closest position.
- c. A single “**Rear Wing SLM Adjuster Fairing**”, across both sides of the car, which must lie in its entirety within **RV-RW-SLM-FAIRING**.
- d. Up to three “**Rear Wing Rotation Brackets**”, across both sides of the car, where each must:
 - i. lie in its entirety within an individual, freely positioned instance of **RV-RW-BRACKET**.
 - ii. lie inboard of Y = 20 or outboard of Y = 520.
 - iii. if outboard of Y = 520, intersect both the fixed volumes of **Rear Wing Profiles** and **RW Flap** for the entire range of adjustment.

Furthermore, once all **Rear Wing Auxiliary Components** have been defined:

- e. they must be **Trimmed and Combined** with **Rear Wing Assembly**.
- f. a **Fillet Radius** no greater than 10mm, may be applied along the intersection between **Rear Wing SLM Adjuster Fairing** and **Rear Wing Assembly**. **Fillet Radii**, no greater than 4mm, may be applied along all remaining intersections with **Rear Wing Assembly**.
- g. they must be arranged such that they are not visible from below with **Rear Wing Assembly** in place.

C3.11.8 Rear Wing Bodywork Group

Once the components defined in Articles C3.11.1 to C3.11.7 have been constructed in accordance with these provisions, including any sub-assembly operations, the resulting union is defined as “**Rear Wing Bodywork**”.

C3.12 Final Assembly

Prior to “**Final Assembly**”, all bodywork groups described in these Articles must be fully defined. Furthermore, each proceeding **Final Assembly** sub-section must be complete before moving onto the next.

C3.12.1 Front Bodywork to Rear Bodywork Assembly

The **Front Bodywork** and the **Rear Bodywork** must be trimmed to each other. The result of this assembly will be known as “**Upper Bodywork**”. A **Fillet Radius**, no greater than 50mm, may be applied along the intersections between these volumes.

C3.12.2 Upper Bodywork to Floor Bodywork Assembly

The **Upper Bodywork** and **Floor Bodywork** must be trimmed to each other. Furthermore:

- a. before trimming, any **Engine Cover** remaining below the **Floor Bodywork** must be discarded.
- b. the intersection formed by any remaining **Upper Bodywork** regions and **Floor Bodywork** must produce no more than one curve.
- c. a **Fillet Radius**, no greater than 50mm, may be applied along the intersection between these volumes.

- d. once all volumes are trimmed and filleted, no part of **Engine Cover**, the **Fillet Radius** between **Engine Cover** and **Floor Bodywork**, may be visible from below.

C3.12.3 Tail Bodywork to Floor and Upper Bodywork Assembly

The **Tail** and the **Upper Bodywork to Floor Assembly** must be trimmed to each other. A **Fillet Radius**, no greater than 25mm, may be applied along the intersections between these volumes.

C3.12.4 Front Wing Bodywork to Nose Bodywork Assembly

The **Front Wing Bodywork** and the **Nose** bodywork must be trimmed to each other. Furthermore:

- a. a **Fillet Radius**, no greater than 25mm, may be applied along the intersections between these volumes.
- b. except for **Front Wing Pylon** and **FW SLM Adjuster Fairing**, no part of **Front Wing Bodywork** may intersect **Nose** bodywork.

C3.12.5 Rear Wing Bodywork to Tail Bodywork Assembly

The **Rear Wing Bodywork** and the **Tail Bodywork** must be trimmed to each other. A **Fillet Radius**, no greater than 10mm, may be applied along the intersections between these volumes.

C3.13 Bodywork not defined in Articles C3.5 to C3.12

In addition to the **Bodywork** defined and regulated by Articles C3.5 to C3.12, the following components are permitted:

- C3.13.1** A transparent windscreen, that measures less than 30mm in Z, less than 300mm in Y, and is no more than 3mm thick, may be fixed to the forward face of the **Cockpit** opening and may extend above **RV-CH-MID**.
- C3.13.2** Antennae and pitot tubes may be mounted on the upper surface of the **Survival Cell** ahead of the **Cockpit** opening and may extend above **RV-BODY-FRONT**.
- C3.13.3** ~~The following A fairings~~ may be attached to the **Secondary Roll Structure** ~~defined in C12.4.2~~, or the cameras defined in Articles C8.9.3 and C8.16.6. ~~This fairing:~~
- ~~a. A fairing bonded to the Secondary Roll Structure which must:~~
 - ~~i. lie in its entirety within a 20mm offset from the Secondary Roll Structure or High Speed Camera;~~
 - ~~ii. be above Z=695mm;~~
 - ~~iii. be outside of RV-COCKPIT-HELMET;~~
 - a. must lie in **RV-HALO**.
 - b. must contain no convex radius less than 2mm.
 - ~~b. An additional fairing around the Secondary Roll Structure forward mounting and the camera defined in Article C8.16.6, which:~~
 - ~~i. must lie in its entirety within RV-SECONDARY-ROLL;~~
 - c. may be joined to Front Bodywork with a **Fillet Radius** no greater than 10mm.

C3.13.4 Ducts (as specified in C3.1.a.ii and C3.1.a.iii) and **Primary Heat Exchangers**, which must not be visible when viewed from the outside of the car, at any angle perpendicular to the X-axis. This is assessed with the bodywork defined in Articles C3.5 to C3.12 present but prior to the application of **Apertures** permitted in Articles C3.16.

C3.13.5 A slip sensor and its fairing may be mounted underneath the **Forward Chassis** provided it lies within **RV-SLIP**. The surface of the combined slip sensor and fairings in contact with the external airstream must form a single curve when intersected by any Z plane.

C3.14 Wheel Components

C3.14.1 General Principles

The following principles apply throughout Articles C3.14 and C3.15.

- a. Any **Bodywork** subject to **Wheel Bodywork Assembly** as per Article C3.15 must first be classified under one of the groups specified in Article C3.14.
- b. Unless otherwise specified, all **Bodywork** in Article C3.14 must be present and fitted after **Wheel Bodywork Assembly** as per Article C3.15.
- c. Compliance of each **Bodywork** component defined in Article C3.14 and Article C3.15 with Article C3 will be assessed independently and before any **Trim and Combination** operations and **Fillet** application described in Article C3.15, and any **Aperture** application described in Article C3.16.
- d. Compliance of the **Aerodynamic Surfaces** of each **Bodywork** component in Article C3.14 will be assessed independently and after their boundaries have been defined by **Trim and Combination** operations and **Fillet** application described in Article C3.15, and before any **Aperture** application described in Article C3.16.
- e. When referred to individually, Wheel Components will have the words “Front” or “Rear” prefixed to the Component name.
- f. The Wheel Component name on its own refers to both the Front and Rear Components simultaneously.
- ~~f. Any criterion of visibility will be considered in the Wheel Coordinate System (X_w, Y_w, Z_w) and will assume that the sprung mass, the suspension, the Drum, the Aerodynamic Seals and the complete wheels have been removed.~~

Furthermore, except for permitted **Aerodynamic Seals, Wheel Bodywork** and any **Aerodynamic Seats** must:

- g. be rigid and rigidly secured to the suspension uprights.
- h. not be rigidly secured to the suspension members.

Rigidly secured means not having any degree of freedom.

C3.14.2 Drum

“Front Drum” and “Rear Drum” **Bodywork**, the latter being exempt from Article C3.2.4 (b), must:

- a. be made to the geometry defined by **RS-FWH-DRUM** and **RS-RWH-DRUM** respectively.

Furthermore:

- b. **Drum Bodywork** must be fitted with an **Aerodynamic Seal**, in the outboard of the two annotated volumes, between the **Drum** and the axle. This **Aerodynamic Seal** must be circumferential, continuous (around an arc of 360°), concentric about the Y_W axis, and uniform.
- c. **Drum Bodywork** may be fitted with ~~an **Aerodynamic Seal**~~ a flexible seal or seals, in the inboard of the two annotated volumes, between the **Drum** and the **Wheel Rim**.

C3.14.3 Lip

The **“Front Lip”** and **“Rear Lip” Bodywork** must:

- a. lie in their entirety within **RV-FWH-LIP** and **RV-RWH-LIP** respectively.
- b. have up to two sections in any X_W and Y_W -Plane.
- c. be fully visible from either inboard or outboard, such that any surface obscured from one direction is visible from the other.

Furthermore, ~~Rear Lip bodywork must:~~

- d. **Front Lip Bodywork** is optionally fitted and exempt from Article C3.14.1 (b).
- e. **Rear Lip Bodywork** must have up to two sections in any Z_W -Plane below $Z_W = -210 - 170$.
- f. compliance with (c) is not required within regions obscured by **RS-RWH-DRUM** when viewed from outboard.

Lip Aerodynamic Surfaces must:

- ~~e. be fully visible from either inboard or outboard, such that any surface obscured from one direction is visible from the other.~~
- g. contain no concave radius of curvature less than 20mm.
- h. contain no convex radius of curvature less than 20mm.

Furthermore:

- ~~h. compliance with (c) is not required within regions which are obscured by **RS-RWH-DRUM** when viewed from outboard.~~
- i. compliance with (h) is not required within 10mm of the side-view boundary of the **Lip** when viewed from inboard or outboard.
- j. compliance with (g) and (h) is not required on the **Rear Lip** within a single transition between one and two Z_W sections that is contained within two Z_W -Planes up to 10mm apart.
- ~~j. **Front Lip** is optionally fitted and exempt from Article C3.14.1 (b).~~

C3.14.4 Scoop

The **“Front Scoop”** and **“Rear Scoop” Bodywork** must:

- a. lie in their entirety within **RV-FWH-SCO** and **RV-RWH-SCO** respectively.

Furthermore, **Rear Scoop Bodywork** rearwards of $X_W = 0$:

- b. is exempt from Article C3.2.4 (b).

Scoop Aerodynamic Surfaces must:

- c. be fully visible from inboard.
- d. contain no radius of curvature less than 20mm, except for regions of the **Rear Scoop** rearwards of $X_W = 0$.

C3.14.5 Rear Drum Deflector

“Rear Drum Deflector” Bodywork must:

- a. lie in its entirety within **RV-RWH-FDEF**.
- b. have up to two sections in any X_W , Y_W and Z_W -Plane below $Z_W = -170$.
- c. in any Z_W -Plane, within 50mm of the rearmost point, a line tangent to any part of the section visible from inboard must not form an angle greater than 5 degrees when measured against the X_W -axis.

Furthermore:

- d. **Rear Drum Deflector Bodywork** is optionally fitted and exempt from Article C3.14.1 (b).

Rear Drum Deflector Aerodynamic Surfaces must:

- e. contain no concave radius of curvature less than 50mm.

Furthermore:

- f. compliance with (e) is not required within a single transition between one and two Z_W sections that is contained within two Z_W -Planes up to 10mm apart.

~~f. compliance with (e) will be assessed prior to the application of any **Edge Radius** used to establish Tangency Continuity.~~

~~g. **Rear Drum Deflector** bodywork is optionally fitted and exempt from Article C3.14.1 (b).~~

C3.14.6 Front Drum Front Deflector

“Front Drum Front Deflector” Bodywork, if present, must:

- a. lie in its entirety:
 - i. within an axis aligned cuboid of the following dimensions $[X_W, Y_W, Z_W] = [150, 45, 25]$, which may be freely translated along any axis, and rotated about the Y_W axis only.
 - ii. below $Z_W = 0$.
- b. comprise of up to two, non-intersecting, simply connected volumes.
- c. have up to two sections in any X_W , Y_W or Z_W -Plane.
- d. not be visible from inboard with the **Front Lip** present.

Furthermore,

- e. **Front Drum Front Deflector Bodywork** is optionally fitted and exempt from Article C3.14.1 (b).

C3.14.7 Front Drum Rear Deflector

“**Front Drum Rear Deflector**” **Bodywork**, which is exempt from Article C3.2.4, results from the **Trim and Combination** of the following components:

- a. **RS-FWH-RDEF**.
- b. **Deflector Leading Edge**, which must:
 - i. lie in its entirety within **RV-FWH-RDEF**.
 - ii. contain no more than a single section in any X_w - ~~Y_w~~ and Z_w -Plane.
 - iii. obscure **RS-FWH-TOP** when viewed from inboard.

~~Deflector Leading Edge~~ **Front Drum Rear Deflector Aerodynamic Surfaces** must:

- c. in any X_w -Plane forward of $X_w = 150$, contain no concave radius of curvature:
 - i. less than 75mm visible from outboard.
 - ii. visible from inboard.
- d. in any X_w -Plane rearward of $X_w = 150$, contain no concave radius of curvature less than 50mm.
- e. be no more than 15mm thick (being the minimum distance when measured normal to the surface), if visible from inboard.

Furthermore:

- f. compliance with (e) is not required within 5mm of the side-view boundary of the **Aerodynamic Surfaces of Front Drum Rear Deflector** when viewed from inboard.

C3.14.8 Drum Deflector Stay

Up to three “**Front Drum Deflector Stays**” may be present, each of which must:

- a. lie in its entirety within a right circular cylinder of diameter no greater than 20mm.
- b. lie no closer than 20mm to any other **Front Drum Deflector Stay**.
- c. in any plane normal to the axis of the right circular cylinder defined in (a), have at least one axis of symmetry.

“**Rear Drum Deflector Stay**” **Bodywork** may be present, but must:

- d. lie in its entirety within both:
 - i. **RV-RWH-STAY**.
 - ii. an axis aligned cuboid of dimensions $[X_w, Y_w, Z_w] = [90, 150, 25]$, which may be freely translated **along any axis**, and rotated about the Y_w axis only.
- e. in any Y_w -Plane: ~~have at least one axis of symmetry~~
 - i. **have at least one axis of symmetry where the larger one will be called the ‘major axis’.**
 - ii. **have no dimension which exceeds 5mm larger than the major axis.**

Furthermore, all **Drum Deflector Stay Bodywork**:

- f. is optionally fitted and exempt from Article C3.14.1 (b).

C3.14.9 Wheel Auxiliary Components

The following “**Wheel Auxiliary Components**”, which are optional and exempt from Article C3.14.1 (b), may be fitted:

- a. Up to three **Hangers**, each of which must:
 - i. intersect the **Front Lip** and the union of **Front Drum** and **Front Scoop**.
 - ii. be no closer than 100mm to any other **Hanger**.
 - iii. not be visible from inboard with the **Front Drum**, **Front Lip** and **Front Scoop** present.
 - iv. in any Y_w -Plane, have at least one axis of symmetry where the larger one will be called the ‘major axis’.
 - v. in any Y_w -Plane, have no dimension which exceeds 2mm larger than the major axis.
- b. To protect the **Scoop** inlet from debris ingestion, a “**Front Debris Guard**” and “**Rear Debris Guard**”, which are exempt from Article C3.2.4, must:
 - i. lie in their entirety within **RV-FWH-SCO** and the union of **RV-RWH-SCO** and **RV-RWH-LIP** respectively.
 - ii. when assessing each **Debris Guard** individually, form one or more closed sections, each with a cross-sectional area no greater than 8mm² when intersected by any Y_w -plane.

C3.15 Wheel Bodywork Assembly

Prior to “**Wheel Bodywork Assembly**”, all **Bodywork** groups described in Article C3.14 must be fully defined. Furthermore, each proceeding **Wheel Bodywork Assembly** sub-section must be completed before moving on to the next.

C3.15.1 Scoop to Drum

“**Scooped Drum**” **Bodywork** results from the **Trim and Combination** of the respective **Drum** and **Scoop**. A **Fillet Radius** no greater than 20mm may be applied at the intersection between these volumes.

C3.15.2 Lip to Scooped Drum

“**Outboard Wheel**” **Bodywork** results from the **Trim and Combination** of the **Scooped Drum** and **Lip** components. A **Fillet Radius** no greater than 20mm may be applied at the intersection between these volumes.

Furthermore:

- a. if present, the **Front Drum Front Deflector**, defined in Article C3.14.6, must be **Trimmed and Combined** to the **Front Outboard Wheel**. **Fillet Radii** no greater than 5mm may be applied at the intersections between these volumes.
- b. if present, the **Hangers**, defined in Article C3.14.9 (a), must be **Trimmed and Combined** to the **Front Outboard Wheel**. **Fillet Radii** no greater than 4mm may be applied at the intersections between these volumes.

- c. if present, the **Debris Guard**, defined in Article C3.14.9 (b), must be **Trimmed and Combined** to the **Outboard Wheel**. **Fillet Radii** no greater than 4mm may be applied at the intersections between these volumes.

C3.15.3 Rear Drum Deflector to Rear Outboard Wheel

The **Rear Outboard Wheel**, **Rear Drum Deflector** and **Rear Drum Deflector Stay**, if present, must be **Trimmed and Combined** to each other and **Fillet Radii** no greater than 10mm may be applied at the intersections between these volumes.

After trimming, **Rear Drum Deflector Stay**, if present, must not be visible from inboard or outboard.

The result of this union will be known as “**Rear Wheel Bodywork Assembly**”, which must form a single, simply connected volume.

C3.15.4 Front Drum Rear Deflector to Front Outboard Wheel

The **Front Outboard Wheel**, **Front Drum Rear Deflector** and **Front Drum Deflector Stays**, if present, must be Trimmed and Combined to each other and a **Fillet Radius** no greater than 10mm may be applied at the intersections between these volumes.

After trimming, **Front Drum Deflector Stay**, if present, must not be visible from inboard.

The result of this union will be known as **Front Wheel Bodywork Assembly**.

C3.15.5 Internal Cooling Ducts

“**Internal Cooling Ducts**” are exempt from Article C3.2.4 ~~and the requirement to be Tangent Continuous~~, but must lie in their entirety within **Scooped Drum**. ~~Furthermore,~~ Once the **Apertures** in Article C3.16 have been applied, any flow linking the **Scoop Inlet** to the **Scoop Outlet** must:

- a. pass through ~~a Y_w the plane outboard of $Y_w = -50$, with the exception of~~ **except for** ducts that cool electrical components.

Furthermore, any flow which enters the **Scooped Drum** must:

- b. not have any resultant flux across a circular section 155mm in diameter with its centre lying on the Y_w axis in the plane $Y_w = -182$ and $Y_w = -211$ for the Front and Rear respectively.

C3.16 Apertures

Once the **Final Assembly** and **Wheel Bodywork Assembly** have been fully defined, the apertures listed in the following table may be applied. “**Apertures**” shall be interpreted as mathematical surfaces bound by their peripheries and can only be defined after their respective **Reference Volume** has been translated and rotated. Unless otherwise stated, each aperture may only be applied once, and must:

- a. lie in its entirety within the stated **Aperture RV**. Unless otherwise stated, each individual “**Aperture RV**”:
 - i. is an axis aligned cuboid that is bounded by a single internal diagonal extending from [0,0,0] to the stated co-ordinates.
 - ii. may be freely translated in space.

- iii. may be rotated about [0, 0, 0] within the prescribed limits. [X° Limit, Y° Limit, Z° Limit]. Any rotation must be applied before any translation.

All **Aperture RVs** are referenced to the **Car Coordinate System** except for the Wheel Bodywork **Aperture RVs** which are referenced to the **Wheel Coordinate System**.

- b. be a simply connected surface.
- c. be fully coincident with the surface of the stated **Bodywork** component and any permitted **Fillet** or **Edge Radius** applied to the associated **Bodywork** group.
- d. have a surface area no greater than the stated area, per side of the car.
- e. unless otherwise stated, and with only the corresponding **Bodywork** group and **Fillet** or **Edge Radius** defined in (c) present, be fully visible from the given direction, with the **Aperture** surface assumed to be non-transparent.
- f. respect all other stated criteria.
- g. not overlap any other **Aperture**, except for **C3.16.15**.
- h. except for ~~minor~~ incidental flows, which the FIA may request be demonstrated, only result in ~~the stated direction a majority of through~~ flux through the **Aperture** in the stated direction, when considered relative to the **Bodywork**. Furthermore, if no direction is stated, the flux direction will not be assessed.

	(c)	(a.i) / (a.iii)	(d)	(e)	(f)	(h)
C3.16.1 Nose	Nose	[15, 40, 20] [0°, ±10°, 0°]	750	Front	i. Must lie in its entirety forward of $X_F = -1100$.	Influx
C3.16.2 Driver Cooling	Driver Cooling	[20, 100, 20] [0°, ±10°, 0°]	1500	Front		Influx
C3.16.3 FW SLM Actuator	Front Wing Bodywork or Nose	[20, 20, 120] [10°, 10°, 10°]	see limb. (f) (i).	None	i. Must not exceed the size necessary to accommodate a 5mm offset of the Swept Bounding Volume of FW SLM Linkage across the combined range of deviation defined in C3.10.10 (l) and (n). ii. May be fitted with a flexible seal that does not exceed the minimum size necessary to fully close the Aperture.	
C3.16.4 FW SLM Adjuster	Front Wing Bodywork or Nose	[20, 20, 20] [0°, 0°, 0°]	200	None		
C3.16.5 FSU IB	Nose and Forward Chassis	[90, 10, 30] [0°, ±10°, ±10°]	2500	Side	i. Up to two apertures (one each for push/pullrod and trackrod) are permitted. ii. No point on the aperture may be more than 100mm from any other point.	
C3.16.6 F-Scoop Inlet	Front Scoop	[50, 125, 200] [0°, 0°, 0°]	15,000	None	i. Except for minimal incidental leakage, all air which enters the Front Scoop Inlet must exit the Front Scoop Outlet.	Influx

	(c)	(a.i) / (a.iii)	(d)	(e)	(f)	(h)
C3.16.7 F-Scoop Outlet	Front Scoop	[75, 125, 200] [0°, 0°, 0°]	15,000	Rear	i. Must lie in its entirety rearward of $X_w = 100$ and above $Z_w = -50$ and no closer than 180mm from the Y_w axis. ii. Except for minimal incidental leakage, only air which has entered the Front Scoop Inlet shall exit the Front Scoop Outlet.	Efflux
C3.16.8 Floor Auxiliary	Floor	[10, 80, 80] [0°, ±20°, 0°]	1500	Front	i. Must lie in its entirety above $Z = 100$ and forward of $X_F = 650$.	Influx
C3.16.9 Sidepod Inlet	Sidepod	[20, 475, 250] [0°, ±80°, ±35°]	80,000	Front	i. Must lie in its entirety above $Z = 275$.	Influx
C3.16.10 Cockpit Entry	Chassis Mid	[850, 200, 200] [0°, 0°, 0°]	175,000	Above	i. Visibility must be assessed with the Secondary Roll Structure removed.	
C3.16.11 EC Louvre Cooling	Engine Cover	RV-BW- APERTURE [0°, 0°, 0°]	150,000	None	i. RS-BW-APERTURE must be fully obscured when viewed through the aperture from above. ii. when viewed from the outside of the car, at any angle perpendicular to the X-Axis, any visible exposed surfaces must lie in their entirety within 50mm of the untrimmed surface. iii. Must not be translated.	Efflux
C3.16.12 EC Y25 Cooling	Engine Cover	[1200, 25, 50] [0°, ±20°, 0°]	30 000	Above	i. Must lie in its entirety inboard of $Y = 25$. ii. After the aperture has been applied, RS-EC must remain fully obscured when viewed from the side.	Efflux
C3.16.13 EC Rocket	Engine Cover	[10, 300, 350] [0°, 0°, 0°]	100,000	Rear	i. Must lie in its entirety rearward of $X_R = -55$.	Efflux
C3.16.14 R-Tyre Sensor	Floor or Engine Cover	[5, 60, 30] [0°, ±20°, ±45°]	1500	Rear	i. Must be fully obscured from below with Floor Body present.	
C3.16.15 RSU IB	Engine Cover	[200, 50, 140] [±90°, 0°, ±90°]	12 000	None	i. A single aperture is permitted for each suspension member and driveshaft. ii. No point on the aperture may be more than 200mm from any other point. iii. At the legality ride height defined in Art 10.1.4, for parts forward of $X_R = -55$, the aperture must enclose the suspension member or driveshaft, including its fairing.	Efflux
C3.16.16 R-Scoop Inlet	Rear Scoop	[50, 100, 175] [0°, 0°, 0°]	10,000	None	i. Except for minimal incidental leakage, all air which enters the Rear Scoop Inlet must exit the Rear Scoop Outlet.	Influx
C3.16.17 R-Scoop Outlet	Rear Scoop	[150, 100, 175] [0°, 0°, 0°]	10,000	Rear	i. Must lie in its entirety rearward of $X_w = 100$ and above $Z_w = -50$. ii. Except for minimal incidental leakage, only air which has entered the Rear Scoop Inlet shall exit the Rear Scoop Outlet.	Efflux

C3.17 Suspension and Driveshaft Fairings

C3.17.1 “**Suspension Fairings**” must be fitted to all suspension members defined in Article C10.3.6, except for those of circular cross section. Furthermore, **Suspension Fairings must be internally sealed to prevent any internal airflow.**

C3.17.2 Each **Suspension Fairing**, relative to its corresponding suspension member, must:

- a. fully cover the member and any components mounted to the member, over the span exposed to the **External Air Stream**.
- b. be rigid and have zero degrees of freedom relative to the member. Except for suspension conforming to Article C10.3.3, where minimal deformation or articulation will be allowed in shared cover sections to accommodate nominal misalignment of relevant suspension members through the suspension travel range.
- c. lie entirely ahead of $X_R = 300$.

C3.17.3 The surface bounded by the external cross-section of each **Suspension Fairing**, when taken normal to the corresponding suspension member’s load line defined in Article C10.3.6 (a) must:

- a. intersect the load line, except for front suspension elements, locally, for the sole purpose of ensuring minimum clearance with the **Wheel Rim** at full steering lock.
- b. have at least one axis of symmetry where the larger one will be called the "major axis."
- c. have no dimension which exceeds:
 - i. 100mm.
 - ii. 5mm larger than the major axis.
- d. have an aspect ratio no greater than 3.5:1, where aspect ratio is the ratio of the major axis to the maximum thickness, measured in the direction normal to the major axis.
- e. have an incidence (defined as the angle between the major axis and the plane $Z=0$ with the car at its legality ride height, as defined in Article C10.1.4) which lies within the following ranges:
 - i. For Front **Suspension Fairings**, between 10deg (nose down) and 0deg.
 - ii. For Rear **Suspension Fairings**, between 10deg (nose down) and -10deg (nose up).

C3.17.4 ~~Fairings of suspension~~ **Suspension Fairings** of members which share an attachment point will be considered by a virtual dissection into discrete components. Such fairings will be allowed ~~local~~ **minimally necessary** exceptions to Article C3.17.3 (b), (c.ii), (d) and (e) close to the junction of the suspension members, including minimal cut outs to allow the passage of a suspension member connected inboard to the rockers defined in Article C10.4.1. After application of any such cut out, the resultant fairings must still seal the internal volume of the fairings from the external airstream.

C3.17.5 A “**Driveshaft Fairing**” may be fitted around the driveshaft defined in Article C9.10 ~~and must cover the driveshaft and any component mounted to it, over the span exposed to the External Air Stream. This fairing must not vary the angle subtended by the major axis of its cross-section (C3.17.3.b) and the plane $Z=0$ by more than +5deg from that at Legality Ride Height over the range of suspension movement.~~ Furthermore, this fairing must be internally sealed to prevent any internal airflow.

Furthermore, The surface bounded by the external cross-section of this fairing, when taken normal to the driveshaft a single nominated legality axis must:

- a. respect the criteria of Article C3.17.3 except for:
 - i. part (a), which must instead intersect the driveshaft legality axis.
 - ii. part (c.i), which is increased to 150mm.
 - iii. part (e), where the range is between 10deg (nose down) and -10deg (nose up).

Furthermore, this fairing must not vary the angle subtended by the major axis of its cross section (~~C3.17.3.b~~) when taken normal to the legality axis, and the plane Z = 0 by more than ±5deg from that at **Legality Ride Height** over the range of suspension movement.

C3.17.6 The angle between the normal to any point of the surface of a **Suspension** or **Driveshaft Fairing** and a plane normal to the corresponding suspension member's load line or driveshaft axis must not exceed 15 degrees. Except for, regions close to inner and outer attachment points, or close to the junction between suspension members that share an attachment.

C3.17.7 In order to permit suspension travel while maintaining an **Aerodynamic Seal**, minimal flexible components may be fitted between a **Suspension** or **Driveshaft Fairing** and the following components:

- a. **Wheel Bodywork**, as defined in Article C3.15.
- b. **Front Bodywork**, as defined in Article C3.7.
- c. **Engine Cover Bodywork**, as defined in Article C3.8.2.
- d. **Tail Bodywork**, as defined in Article C3.9.
- e. **Gearbox Case**, as defined in Appendix C1.
- f. **Rear Wing Pylon**, as defined in Article C3.11.4.
- g. The **Suspension Fairing** covering the suspension member connected inboard to the rockers defined in Article C10.4.1.

With the car at its Legality Ride Height, these flexible components must:

- h. contain a **Fillet Radius** of up to 30mm between the components they are sealing.
- i. except for the **Fillet Radius** defined in (h), conform with the shape restrictions of the two components they are sealing. For clarity, parts of these components may be replaced with the flexible component.
- j. be designed in such way as to maintain their shape integrity with the car in motion, and as much as possible, with the suspension at another position than that of the Legality Ride Height.

When the suspension is at the Legality Ride Height and the Wheels are in the straight-ahead position, exceptions to (h) and (i) are permitted in regions internal to the volume bounded by the **Fillet Radius** defined in (h) between:

- k. **Suspension Fairings** and **Front Wheel Bodywork**.
- l. the Front Trackrod **Suspension Fairing** and **Front Bodywork**.

C3.17.8 **Suspension Fairings** may be united with the ~~and~~ **Driveshaft Fairing** ~~may be united~~ to form a solitary fairing. Such a fairing will be considered by a virtual dissection into discrete **Suspension** or **Driveshaft Fairings**. Furthermore, the discrete **Suspension** and **Driveshaft Fairings** which form the solitary fairing, may have minimally necessary exceptions to Article C3.17.3 (b), (c.ii), (d) and (e), Article C3.17.5 (a.iii) and Article C3.17.6, close to a single junction where these fairings transition from virtually discrete to physically discrete.

C3.18 Aerodynamic Component Flexibility

C3.18.1 Introduction of load/deflection tests

Bodywork subjected to load/deflection tests in this Article must be of rigid construction and exhibit nominally linear elastic behaviour up to the maximum load applied whilst running on track, unless stated otherwise.

Any system, mechanism, or procedure, that achieves, seeks to, or is suspected of, circumventing the tests defined in this Article is prohibited.

In order to ensure that the requirements of Article C3.2.2 are respected, the FIA reserves the right to introduce further load/deflection tests, **modify existing tests**, or require **F1 Teams** to provide further evidence as stated in Article C1.7, for any part of the bodywork which appears to be, or is suspected of, moving whilst the car is in motion.

Further details about the implementation of each test are given in [FIA-F1-DOC-C037](#).

C3.18.2 Front Wing Bodywork Flexibility

The flexibility of **Front Wing Bodywork** will be tested by applying a load of [0, 0, -1000] N at points $[X_F, Y, Z] = [\text{~~-800, +550, 300~~ or } [-1000, +550, 300] [-925, +525, 300]$.

The load will be applied in a downward direction using a 50mm diameter ram on a rectangular adaptor measuring 350mm in the X-direction and 100mm in the Y-direction. This adaptor must be supplied by the team and should:

- have a flat top surface without recesses.
- be fitted to the car to apply the full load to the bodywork at the test point and not to increase the rigidity of the parts being tested.
- be placed with the inner face ~~525mm~~ 475mm from $Y = 0$.
- be placed with its forward face at $X_F = \text{~~-1065} - 1100~~$.
- be placed with its top face at $Z=300$.
- have a mass of no more than 2kg.

The deflection will be measured relative to the **Survival Cell** and along the loading axis.

When the load is applied symmetrically to both sides of the car the vertical deflection must be no more than 15mm.

When the load is applied to only one side of the car the vertical deflection must be no more than 20mm.

C3.18.3 Front Wing Flap Flexibility

Any part of the trailing edge of ~~any Front Wing Flap~~ either **FW Primary Flap** or **FW Secondary Flap** may deflect no more than 10mm, when measured along the loading axis, when a 60N point load is applied normal to the flap.

When tested, the flap must be in **Cornering Mode**.

The load will be applied through a 25mm diameter rubber pad which will be entirely on the flap surface.

Deflection will be measured relative to the forward-most element of **Front Wing Profiles**.

C3.18.4 Front Wing Endplate Flexibility

~~a. The Front Wing End Plate may deflect no more than 5mm, when measured along the loading axis, when a 50N vertical load is applied at points $[X_c, Y_c]$ $[-380, +875]$.~~

~~Teams must provide a suitable means of applying the load to the upper surface of the bodywork. The load will be applied through a rod of diameter 2.3mm. Details of this arrangement are provided in the document FIA F1 DCC Cxxx. The contact of any load spreader with the bodywork must lie within a cylinder of diameter 15mm, coaxial with the load application axis. If the Team's preferred method requires through holes, these holes must be sealed on either or both of the upper and lower surfaces at all times the car is on the circuit and during any assessment of any visibility from above around load application points.~~

- a. The **Front Wing Endplate** may deflect no more 7mm when a 60N load is applied vertically downwards anywhere on its periphery.
- b. The **Front Wing Endplate** may deflect no more 7mm when a 60N load is applied in the Y-direction, anywhere on its periphery.

The load will be applied through a 25mm diameter rubber pad which will be entirely on the bodywork surface.

Deflection will be measured relative to the forward-most element of **Front Wing Profiles**.

C3.18.5 Front Floor Flexibility

Bodywork flexibility will be tested by applying a load vertically upwards through ~~two~~ a 10mm diameter pad. The load will be applied anywhere on the lower surface of **RV-SKID-FWD**. ~~pads mounted diametrically opposite on the edges of a 48mm diameter pad with a gimble interface to the loadcell. The centre of the pad will be positioned at $[X_c = 500, 0]$~~

The deflection will be measured along the loading axis. ~~and the deflection limits below must be respected for all rotational orientations of the 48mm pad about the Z axis:~~

At all times during the test, the load at a given deflection must exceed the load given by a straight-line graph defined by connecting the following coordinates in order:

(0mm, 0N), (8mm, 8000N) (25mm, 8000N).

This must be the case whether the deflection is increasing, decreasing, or held constant. The test will have no more than a maximum load of ~~8000N~~ **10000N** or a maximum deflection of 15mm

(whichever is reached first) unless specifically requested by the FIA to investigate behaviour above these limits.

The load deflection relationship must be strictly monotonic with both increasing and decreasing deflection.

C3.18.6 Outboard Floor Flexibility

The ~~outboard edge of the~~ **Floor Bodywork Group** may deflect no more than 8mm in Z, ~~at any point between $X_R = 1260$ and $X_R = 350$,~~ when a ~~distributed~~ load of $[0, 0, -500]$ N is applied to each side of the car.

The loads will be applied simultaneously ~~at five points on each side of the car, nominally at $[X_R, Y = 650]$, $[X_R = -525, Y = \pm 550]$.~~

Loads will be applied using weights. The **F1 Team** must provide 50mm diameter adapters, centred on the load axis. Bodywork must have holes to allow a 2.3mm diameter rod to pass through. All holes required must be sealed on both upper and lower surfaces whenever the car is on the circuit.

~~a. $[-480], [-635], [-790], [-945], [-1100]$.~~

~~A 2mm tolerance on position will be permitted for manufacturing reasons:~~

~~When viewed from above, and with the **Floor Bodywork Group** as fully defined in Article C3.5.8 in place, nothing other than the bodywork may be visible within 15mm of any load application point. A load application point that does not meet this requirement may be moved, in X and/or in Y, by the minimum amount necessary to comply. The FIA may require load points to be moved if, in their view, the load location or the floor shape has been specifically designed to permit greater levels of outboard floor flexibility in untested regions of the floor.~~

~~Once the load application positions are fully defined, Teams must provide a suitable means of applying the load to the upper surface of the bodywork. The load will be applied through a rod of diameter 2.3mm. Details of this arrangement are provided in the document FIA-F1-DOC-Cxxx. The contact of any load spreader with the bodywork must lie within a cylinder of diameter 25mm, coaxial with the load application axis. If the Team's preferred method requires through-holes, these holes must be sealed on either or both of the upper and lower surfaces at all times the car is on the circuit and during any assessment of any visibility from above around load application points.~~

Loads will be applied to these rods in two stages:

- a. ~~$[0, 0, -50]$ N to each load application point to give 250N per side.~~
- b. ~~$[0, 0, -100]$ N to each load application point to give 500N per side.~~

Deflection will be measured relative to the rear scrutineering supports defined in C3.3.4. ~~by laser scanning of the bodywork at each loading stage.~~

C3.18.7 Central Floor Flexibility

Local bodywork flexibility within RV-PLANK will be tested by applying a load vertically upwards through ~~two~~ three 10mm diameter pads equispaced on a 45mm pcd ~~mounted diametrically opposite on the edges of a 45mm diameter pad with a gimble interface to the loadcell. The 45mm pad will be positioned by the FIA such that it is~~ centred on one of the holes in RV-PLANK between $X_F = 800$ and X_R . The pads will have a gimble interface to the loadcell.

The deflection will be measured along the loading axis and the deflection limits below must be respected for all rotational orientations of the pads about the axis of the hole. ~~45mm pad about the Z-axis.~~

At the hole positioned between $X_c = -600$ and $X_c = -800$, the stiffness must exceed 3kNmm^{-1} and must show a linear relationship to displacement up to and beyond 6kN.

At the hole positioned at the rear of the plank, the stiffness must exceed 6kNmm^{-1} and must show a linear relationship to displacement up to and beyond 10kN.

Deflection will be measured relative to the scrutineering supports defined in C3.3.4.

~~At all times during the test, the load at a given deflection must exceed the load given by a straight line graph defined by connecting the following coordinates in order:~~

~~(0 mm, 0 N) (1mm, 8000N).~~

C3.18.8 Floor Board Flexibility

- a. The **Floor** bodywork may deflect no more than 5mm, when measured along the loading axis, when a 100N vertical load is applied at points $[X_F, Y] = [695, \pm 720]$.

Loads will be applied using weights. The **F1 Team** must provide 25mm diameter adapters, centred on the load axis. Bodywork must have holes to allow a 2.3mm diameter rod to pass through. All holes required must be sealed on both upper and lower surfaces whenever the car is on the circuit.

Deflection will be measured relative to the front scrutineering supports defined in C3.3.4.

- b. **Floor** bodywork must deflect no more than 7mm when a load of $[0, \pm 60, 0]\text{N}$ (inboard or outboard) at any point around its periphery. The load will be applied through a 25mm diameter rubber pad which lies entirely on the bodywork.

Deflection will be measured relative to the front scrutineering supports defined in C3.3.4.

C3.18.9 Diffuser Flexibility

- a. **Floor Bodywork** must deflect no more than 5mm when two loads of $[0, 0, -100]\text{N}$ are applied symmetrically at $Y = \pm 320$ or $Y = \pm 215$ and 15mm forward of the rearward extremity of the Floor Bodywork at these planes.

Loads will be applied using weights. The **F1 Team** must provide 25mm diameter adapters, centred on the load axis. Bodywork must have holes to allow a 2.3mm diameter rod to pass through. All holes required must be sealed on both upper and lower surfaces whenever the car is on the circuit.

Deflection will be measured relative to the **RIS**.

- b. **Floor Winglet** bodywork must deflect no more than 7mm when a 60N load is applied normal to the surface at any point.

The load will be applied through a 25mm diameter rubber pad which lies entirely on the bodywork.

Deflection will be measured relative to the **RIS**.

C3.18.10 Rear Wing Bodywork Flexibility

Bodywork may not deflect more than 6mm along the loading axis and 1.0° in a Y-Plane, when two loads of [325, 0, -1465] N each, are applied simultaneously to the **Rear Wing Profiles**. The loads will be applied at [$X_R = 835, \pm 325, 390$]

The loads will be applied through adaptors, supplied by the team, that lie between 275mm and 375mm from $Y=0$ and between $X_R = 200$ and at least $X_R = 450$. The upper surface each adaptor must lie at $Z = 835$ and should have a counterbore of 52mm diameter for the application of the load in (b). The adaptor must only contact the forward most volume of **RW PROFILES**.

The angular deflection will be measured on the rear wing profiles, at [X_R, Y] [375, ± 450] and relative to the Rear Impact Structure.

~~b. Two loads of [513, 0, -1410]N will be applied to the volumes in **RW PROFILES** at $Y = \pm 325$. The load will be distributed so that 75% is applied to the forward most volume at 50% of the chord and 25% will be applied to each of the other section or sections at 25% of the chord. Clarification of the positions is given in the document FIA-F1-DOC-Gxxx. Under this load:~~

~~i. deflection along the loading axis must be less than 6mm;~~

~~ii. rotation in a Y plane must be less than 1° when measured on the rear wing profiles, at [X_R, Y] [375, ± 450] and relative to the Rear Impact Structure;~~

~~iii. The minimum distance between any two adjacent volumes must not change by more than 2mm at any point along the span.~~

~~F1 Teams will be responsible for providing loading pads and loading yoke.~~

C3.18.11 Rear Wing Flap Flexibility

The RW Flap may deflect no more than 7mm horizontally when a 500N load is applied horizontally. The load will be applied in the plane $Z = 800$ at one of three separate points which lie within 50mm of the car centre plane and 300mm either side of it. The loads will be applied in a rearward direction using a suitable 25mm wide adaptor which must be supplied by the relevant team.

The deflection will be measured along the loading axis and relative to the forward part of the Rear Wing Mainplane at the same Y-station.

C3.18.12 Rear Wing Mainplane Trailing Edge

The forward-most aerofoil element of Rear Wing Profiles may deflect no more than 3mm along the line of load application, when a 200N load is applied normal to the lower surface. The load will be applied in line with the trailing edge of the element at $Y = 0$, $Y = \pm 150$, or at $Y = \pm 450$.

The deflection will be measured relative to the forward part of the Rear Wing Mainplane at the same Y-station.

The loads will be applied using a suitable adaptor, supplied by the relevant team, which:

- a. may be no more than 50mm wide.
- b. which extends no more than 10mm forward of the trailing edge.
- c. incorporates an 8mm female thread in the underside.

C3.18.13 Rear Wing Endplate Flexibility

The Rear Wing Endplates described in Article C3.9.2 may deflect no more than 10mm, when measured along the loading axis, when a 50N point load is applied in an inward direction normal to the car centre plane using a spherical 15mm diameter tip at $[X_R, Z] = [675, 550]$. For this measurement, the contribution of the rigid-body rotation of the whole wing assembly will be removed.

C3.18.14 Rear Wing Skins

The skins of the Rear Wing Profiles may deflect no more than 2mm when a 60N force is applied to the skin normal to and away from the element.

The force will be applied using a vacuum cup of 50mm diameter and the deflection will be measured at the outer diameter of the cup.

C3.18.15 Additional Diagnostics

To allow the behaviour of Bodywork to be monitored, **F1 Teams** are required, as determined by the FIA, to apply contrasting markers to Bodywork and may be required to run additional cameras provided by the FIA. Details and positions of these markers and additional Cameras are given in the document [FIA-F1-DOC-Cxxx](#).

An **F1 Team** may be required by the **FIA** to run **an** additional camera **specified by the FIA** in **Position 2 RHS (C8.16.7) and/or Position 3 (as defined in C8.16)** in any free practice session. Such a camera will not be considered as Bodywork.

C3.19 Aerodynamic Component construction**C3.19.1 Front Wing Endplate**

The bodywork declared as Front Wing Endplate in Article C3.10.6 must be made to the laminate **PL-ANTISPLINTER**.

Fasteners and related inserts, for the purpose of attaching the front wing endplate to the profiles must be positioned at least 30mm rearward of the leading edge of the endplate.

C3.19.2 The **Secondary Roll Structure** fairings, defined in Article C3.13.3, must be made to the laminate **PL-HALO**.

C3.19.3 Floor

Metallic components or metallic inserts are not permitted in the following areas:

- The parts of the bodywork declared as **Floor Bodywork**, which lie forward of $X_R = -335$, outboard of $Y = 400$, and when viewed along the Z-axis, within 50mm of the outboard edge of this bodywork.
- The parts of bodywork declared as **Floor Sidewall** and **Floor Fence** which lie below $Z = 75$.

The following exceptions are permitted:

- Brackets for the stays described in Article C3.5.13 (a) and associated fasteners. No bracket may have a mass greater than 0.1kg.

- d. Wires or rods of 2mm diameter or less, and brackets of the minimal dimensions required for the purpose of holding these in place.
- e. Metallic components added for wear protection provided that:
 - i. No component has a mass of more than 0.03kg.
 - ii. Adjacent components are neither bonded nor mechanically fastened to either each other.
 - iii. All components must be bonded and mechanically fastened to the floor structure.
 - iv. The combined mass of these components is no more than 0.3kg on each side of the car.

C3.19.4 **Bib**

Within 50mm of the Fillet that joins **Floor Bib** to **Main Floor**, isolated sections of either compliant material or thin laminate are permitted to accommodate the motion of the **Floor Bodywork**, as described in Article C3.18.6, and resulting from contact between the plank assembly and the ground.

ARTICLE C4: MASS

Advisory Committee: TAC

Governance: F1 Commission / WMSC

C4.1 Minimum mass

During the **Sprint Qualifying** and **Qualifying** sessions, The **Minimum Mass** is 726kg plus the **Nominal Tyre Mass**. In all other sessions, the **Minimum Mass** is 724kg plus the **Nominal Tyre Mass**.

At all times during the **Competition**, **Car Mass** must not be less than the **Minimum Mass**.

When a **Heat Hazard** is declared, the **Minimum Mass** will be increased by the Heat Hazard Mass Increase.

If, when required for checking, a car is not already fitted with dry-weather tyres, its mass will be determined using a set of dry-weather tyres selected by the FIA technical delegate.

C4.2 Mass distribution

At all times during the **Qualifying** and **Sprint Qualifying** Sessions, with the car resting on a horizontal plane:

- i. the mass measured at the front axle must not be less than the **Minimum Mass** specified in Article C4.1 factored by 0.44.
- ii. the mass measured at the rear axle must not be less than the **Minimum Mass** specified in Article C4.1 factored by 0.54.

If, when required for checking, a car is not already fitted with dry-weather tyres, its mass will be determined using a set of dry-weather tyres selected by the FIA technical delegate.

If, when required for checking, a Heat Hazard has been declared, the increase in mass will not be considered.

C4.3 Ballast**C4.3.1 General**

Ballast can be used provided it is secured in such a way that tools are required for its removal and that it remains immobile with respect to the **Sprung Mass** in its entirety. It must be possible to fix seals if deemed necessary by the FIA technical delegate.

F1 Teams must show by calculation that any ballast fitted within the cockpit would be retained in place if any one of its fixings were removed and it were subjected to a 100g acceleration in any direction.

C4.3.2 Driver Ballast

Ballast designated for the purpose of achieving the driver mass specified in Article C4.5.2 must:

- a. Be entirely located to the car between the front and rear extent of the **cockpit** entry template.
- b. Be attached securely to the **Survival Cell** and sealed by the FIA.
- c. Be clearly identified.

- d. Have a density greater than 7500Kg/m³.
- e. Perform no additional function.

A nominal such mass of 10kg should be present for the impact test described in Article C13.2.

C4.3.3 Ballast Ahead of X_A=0

Any **Ballast** mounted ahead of X_A=0, that is not mounted within the forward-most profile of **Front Wing Profiles**, must be present during the Front Impact Structure Dynamic Test defined in Article C13.6.3.

C4.4 Adding during the Race or Sprint Session

With the exception of compressed gases, no substance may be added to the car during the **Race** or **Sprint Session**. If it becomes necessary to replace any part of the car during the **Race** or **Sprint Session**, the mass of the new part must not be more than that of the original part.

C4.5 Reference Mass of the driver and Driver Ballast

C4.5.1 The reference **Mass of the Driver** will be established by the FIA technical delegate **in accordance with the procedure defined in FIA-F1-DOC-C035** at the first **Competition** of the Championship, this reference mass may be amended at any time during the Championship season if deemed necessary by the FIA technical delegate.

C4.5.2 The reference **Mass of the Driver** plus the mass of any **Driver Ballast** must not be less than 82kg at any time during the **Competition**.

C4.6 Heat Hazard Mass Increase

- a. The Heat Hazard Mass Increase is 5kg.
- b. The sum of the masses of the following items must be no less than 5kg;
 - i. The difference in mass between the driver's personal equipment normally used and that used for a Heat Hazard session.
 - ii. The mass of any driver cooling system not included in (i) above.

C4.7 Determination of Nominal Tyre Mass

To determine the **Nominal Tyre Mass**, the masses of new, production, dry weather, tyres will be measured by the tyre provider and published after the final day of **TCC** opportunity (as defined in Article B11.2.7.b) prior to the start of the **Championship** and will be the mean mass of sample of 50 tyres per axle.

In the case of a change in tyre specification during the **Championship**, the **Nominal Tyre Mass** will be adjusted if required.

ARTICLE C5: POWER UNIT

Advisory Committee: PUAC

Governance: PU Manufacturers' Governance Agreement / WMSC

C5.1 Engine specification

C5.1.1 Only 4-stroke engines with reciprocating pistons are permitted.

C5.1.2 Engine cubic capacity must be 1600cc (+0/-10cc).

C5.1.3 All engines must have six cylinders arranged in a 90° "V" configuration and the normal section of each cylinder must be circular.

All six cylinders must be of equal capacity.

C5.1.4 Engines must have two intake and two exhaust valves per cylinder.

Only reciprocating poppet valves with axial displacement mechanically actuated by the camshafts are permitted.

The sealing interface between the moving valve component and the stationary engine component must be circular. The sealing surfaces on the stationary engine component must be either the **Cylinder Head** itself defined by 15.78.8 g), any coating on the **Cylinder Head** permitted by 15.67.2, or the conventional **Inserts** permitted by 5.19.7 a).

C5.1.5 Engine exhaust gases may only exit the **Cylinder Head** through outlets outboard of the cylinder bore centre line and not from within the "V" centre.

C5.1.6 The crankshaft may only have three connecting rod bearing journals.

C5.1.7 In a **Cylinder Head**, only **Inserts** approved by the FIA Technical Department will be allowed. ~~The total volume of the inserts listed in a. to c. below cannot be more than 3% of the total volume of each Cylinder Head and this these~~ must be confined to:

- a. Conventional valve seat **Inserts** up to a maximum diameter of 4mm larger than the corresponding valve heads
- b. Conventional valve guide **Inserts**
- c. An **insert** whose part residing in the cylinder head is wholly contained in a cylinder of external diameter 15 mm coaxial with the axis of the spark plug concentric to the spark plug axis with a maximum outside diameter of 15mm

The total volume of the inserts listed above in a. and b. cannot be more than 3% of the total volume of each **Cylinder Head**.

An additional allowance of 1% of the total volume (including all inserts) of each **Cylinder Head** is permitted for **Inserts** other than those mentioned above, including helicoils, but none of these **Inserts** can be exposed to the **Combustion Chamber**.

C5.1.8 Unless specified otherwise, the total volume of **Inserts** within **ICE** components related to items 1 and 4 of the Appendix C4 table1 cannot be more than 10% of the total volume (including all inserts) of the component. **Inserts** in other components are not restricted.

C5.1.9 Dismountable components assembled to the **Cylinder Head** exposed to the combustion chamber must be approved by the FIA Technical Department and are confined to:

- a. The Fuel Injectors
 - b. The spark plugs
 - c. The poppet valves (Article 5.3.4)
 - d. A single component per cylinder to replace an In-Cylinder pressure sensor with a maximum outside diameter of 7mm.
 - e. A component whose part residing in the cylinder head is wholly contained in a cylinder of external diameter 15 mm coaxial with the axis of the spark plug
- C5.1.10** All **Power Unit** breather fluids may only vent to atmosphere and must pass through a single orifice which is positioned behind $X_R=0$, inboard of $Y=100$ and below $Z=400$. No breather fluids may re-enter the **Power Unit**.
- C5.1.11** With the exception of leakage through joints (either into or out of the system) all and only the air entering the **Compressor Inlet** must enter the **Combustion Chambers**.
- C5.1.12** The **Power Unit** may be equipped with a maximum of two **Wastegates** and two **Pop-Off Valves**. Only poppet valves with a circular sealing interface and axial displacement are permitted for the **Wastegate** and **Pop-Off Valves**.
- C5.1.13** Engine oil consumption must never exceed 0.30l/100km in normal operating conditions.
- C5.1.14** All **Wastegate** exit fluids must pass through a **Wastegate** tailpipe which must be connected to the turbine tailpipe, downstream of the turbine wheel.
- C5.1.15** For the purpose of **Component Classification** in Table 1 of Appendix C4, **Thermal Insulation** that is permanently attached to another component or assembly (such as by riveting, bonding, welding, brazing, or plating) will be considered part of that component or assembly.
- C5.1.16** The **Clutch** assembly, including but not limited to friction plates, springs, cover plate, may be fitted to the **Flywheel** but will not contribute to the mass of the **Flywheel**. A **clutch** basket connected directly to the rear of the crankshaft will be classified as a **flywheel**.
- C5.2 Power Unit Energy Flow**
- C5.2.1** The use of any device, other than the engine described in C5.1 above, and the **ERS-K**, to propel the car and/or harvest energy, is not permitted.
- C5.2.2** Energy flows, power and ES state of charge limits are shown in the energy flow diagram below: When the car is on the track a lap will be measured on each successive crossing of the timing line, however, when entering the pits the lap will end, and the next one will begin, at the start of the **Pit Lane**

2026 POWER UNIT ENERGY FLOW
 Legend: **Engine** – **ERS** – **Other**

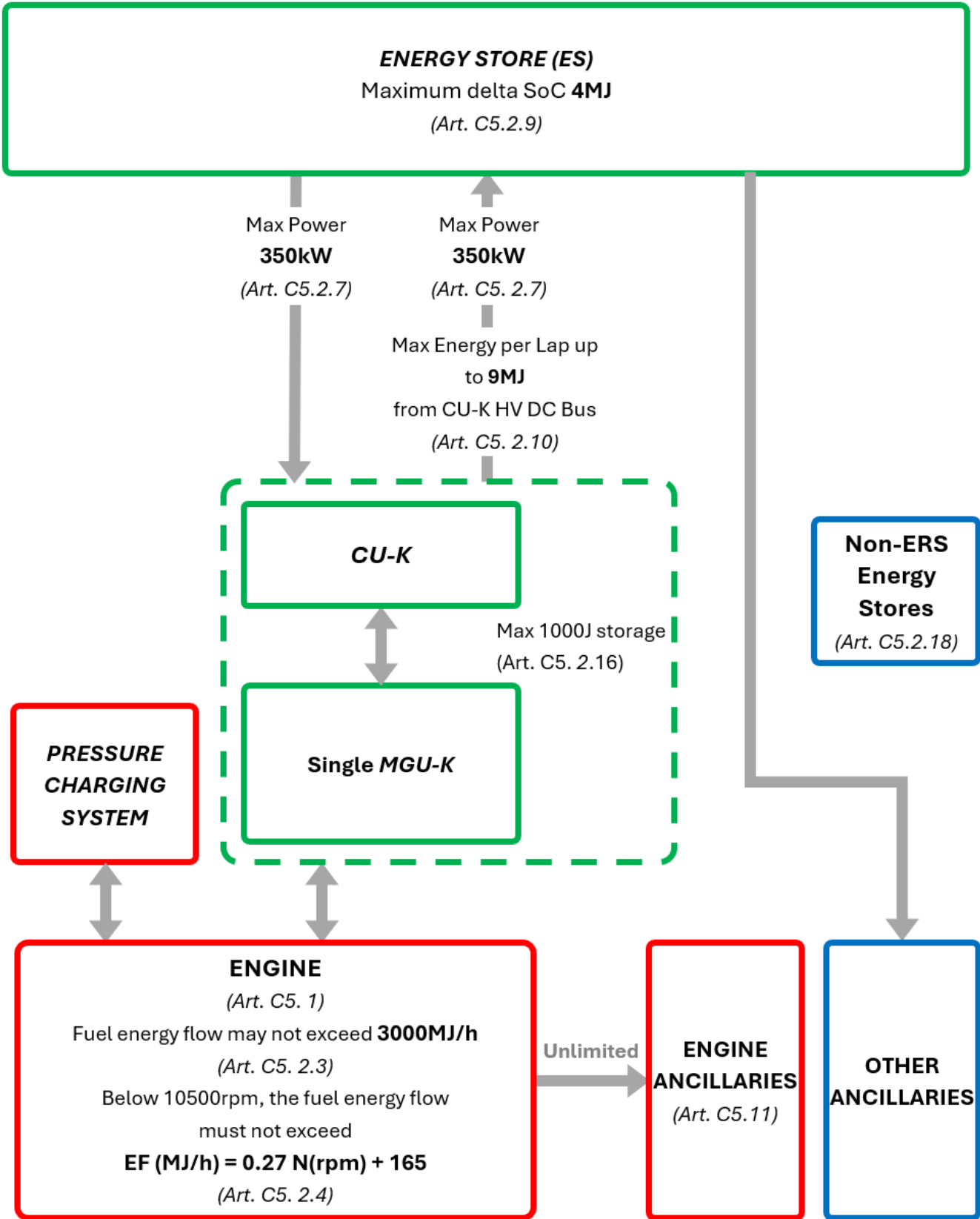

- C5.2.3** Fuel energy flow must not exceed 3000MJ/h.
- C5.2.4** Below 10500rpm the fuel energy flow must not exceed $EF(\text{MJ/h})=0.27*N(\text{rpm})+ 165$
- C5.2.5** At partial load, the fuel energy flow must not exceed the limit curve defined below:
 $EF (\text{MJ/h}) = 380$ when the engine power is equal to or below -50kW
 $EF (\text{MJ/h}) = 9.78 \times \text{engine power (kW)} + 869$ when the engine power is above -50kW

[**Note:** Further discussions will take place to fully evaluate the benefits and consequences of art. C5.2.5 and whether modifications are necessary.]

- C5.2.6** When assessing compliance with the above two articles, the fuel mass flow rates measured by the **Fuel Flow Meter** will be converted in the SECU in fuel energy flow rates using the energy density and the LHV of the fuel as measured by the FIA. The procedure which will be used to determine these values may be found in the document **FIA-F1-DOC-Cxxx**.
- C5.2.7** The absolute electrical DC power of the **ERS-K** may not exceed 350kW.
- C5.2.8** Additionally, and subject to Article B7.2.1, the electrical DC power of the **ERS-K** used to propel the car may not exceed:
- i. $P(\text{kW}) = 1800 - 5 * \text{car speed (kph)}$ when the car speed is below 340kph
 $P(\text{kW}) = 6900 - 20 * \text{car speed (kph)}$ when the car speed is equal to or above 340kph
 $P(\text{kW}) = 0$ when the car speed is equal to or above 345kph
 - ii. In **Override Mode** up to:
 $P(\text{kW}) = 7100 - 20 * \text{car speed (kph)}$ when the car speed is below 355kph
 $P(\text{kW}) = 0$ when the car speed is equal to or above 355kph.
- C5.2.9** The difference between the maximum and the minimum state of charge of the ES may not exceed 4MJ at any time the car is on the track.
- C5.2.10** The energy harvested by the **ERS-K**, as measured at the CU-K **HV DC Bus**, must not exceed 8.5MJ in each lap, subject to the following additional conditions:
- i. ~~Exceptionally, this limit on energy harvested in each lap~~ may be reduced to 8MJ at **Competitions** where the FIA determines that the maximum possible energy harvested per lap under braking and in partial load is no more than 8MJ. ~~These Competitions and the vehicle fundamentals used for the calculation of maximum energy harvested will be provided in the Appendix to the Technical and Sporting Regulations.~~
 - ii. This limit may be further reduced to no less than 5MJ for **Sprint Qualifying** and **Qualifying** sessions at **Competitions** where the FIA determines that the harvesting strategies required to achieve the above limit are excessive, subject to the conditions specified in Article B7.2.
 - iii. Up to 0.5MJ additional energy may be harvested in each lap subject to the conditions specified in Article B7.2 ~~of FIA 2026 F1 Regulations – Section D [Sporting]~~.

The vehicle fundamentals used to determine the above limits will be provided in the document **FIA-F1-DOC-Cxxx**.

- C5.2.11** The MGU-K mechanical torque magnitude may not exceed 500Nm. The torque will be referenced to the crankshaft speed.
- C5.2.12** During a standing start from the grid the MGU-K may only be used once the car has reached 50 km/h.
- C5.2.13** The amount of stored energy in the ES may not be increased by more than 100kJ whilst the car is stationary in the garage during the **Sprint Qualifying** and **Qualifying Sessions**.

C5.2.14 ERS Policing

- a. In order to verify that the energy and power requirements of the ERS are being respected, all cars must be fitted with two DC sensors. Those sensors may only be installed outside the sealed perimeter of any **PU-CE** and used as specified below:

One DC sensor must be connected to the **ES High Voltage** negative DC pole to measure all electrical energy into and out of the **Energy Store** via the **HV DC Bus**.

The other DC sensor must be connected to the **CUK High Voltage** positive DC pole to measure all electrical energy and power into and out of the **ERS-K** via the **HV DC Bus**.

The DC sensors voltage sense wire must be connected to the dedicated measurement point defined by the FIA Technical department.

- b. Electrical energy may not flow from or into the ES and CU-K without being directly measured by one of the two DC sensors, previously listed. This must be guaranteed by design and verifiable by inspection.
- c. The design of the ERS and the installation of the two DC sensors must be approved by the FIA.
- d. An airgap of 1mm must be present between the CU-K and any other consumer fitted inside the **ES main enclosure**. The links allowed to cross the airgap separation volume include, but are not limited to: the elements of the **HV DC bus**, **ERS-K phase conductors**, cooling system components, mechanical support(s), low voltage looms and connectors dedicated for communication lines, low voltage power supply, interlock loop systems, temperature sensors, MGU position sensors, EMC screening and any other sensor used by the **ERS-K**. Those links must be minimal and essential to the CU-K operation.
- e. Details of each **ERS auxiliary circuit** and its connection to any pole of the ERS **high voltage** DC bus must be present in the technical dossier, as stated in Article C5.2.14.c. It shall include circuit diagrams and a table with maximum and minimum values of the electrical current that can flow from or into the **HV DC bus** under normal operating conditions.
- f. With exception of auxiliary circuits, electrical energy with an instantaneous power higher than 2W may not flow from CU-K logic or driver boards (usually low voltage parts) into the CU-K power stage (usually HV). This must be guaranteed by design and verifiable by inspection.
- g. The CU-K must exclusively perform functionalities related to the operation of any MGU-K sensor and to the power conversion between the CU-K DC poles input and the CU-K output going into the MGU-K.
- h. A preliminary technical dossier must be submitted to the FIA before the 21st of March of the year preceding the year of introduction. It must include details justifying all the points

mentioned in this article. They will be pre-homologated by the FIA. Any further modification following the pre-homologation must also be submitted to the FIA.

- C5.2.15** Cars must be fitted with homologated sensors which provide all necessary signals to the FIA data logger in order to verify the requirements defined in this article are being respected.
- C5.2.16** With exception of the ES, the cumulative amount of stored energy on ERS electronic components supplied by voltage sources should not be higher than 1000J.
- C5.2.17** When the car is on the track the maximum instantaneous electrical power linked to the operation of auxiliary circuits (C5.2.28) connected on the ES side of the ES DC Sensor and drawn by the **BMS** directly from the **ES cells** must not exceed 50W in total. This must be guaranteed by design and verifiable by inspection.
- C5.2.18** With the exception of the ERS, the cumulative amount of energy stored in the **Power Unit** should not be higher than 300kJ. Additionally, no more than 20kJ can be recovered per lap at a rate greater than 2kW.
- C5.2.19** When the car is stationary on the grid prior to a standing start the MGU-K torque may only be negative (i.e. charging the ES) except for torque requested by an MGU-K active damping strategy whose sole purpose is to protect the **MGU-K Mechanical Transmission**.
- C5.2.20** No off-board ES charger of any kind may be used whilst the car is in the pitlane
- C5.2.21** A fixed efficiency correction of 0.97, ~~or its inverse where appropriate, will be used wherever it is necessary to convert electrical into mechanical torque.~~ applied when converting electrical physical quantity values into mechanical values

C5.3 Turbo Charger

- C5.3.1** **Pressure charging** may only be affected by the use of a sole single stage, single sided **Turbo Charger** compressor with a single inlet linked to a sole single stage **Turbo Charger** turbine by a shaft assembly. The compressor blades must be attached to a common hub surface and all air entering the **Combustion Chamber** must pass through the single exducer of these blades. The shaft must be designed so as to ensure that the shaft assembly, the compressor and the turbine always rotate about a common axis and at the same angular velocity. With the exception of incidental heat transfer from the **Engine exhaust system** to its surroundings, the energy extracted from the exhaust fluid by the turbocharger turbine is the sole permitted means of transferring energy into the rotating parts of the **Turbo Charger**. The energy of the rotating parts of the **Turbo Charger** turbine may not be transferrable to any other component.

Only parts approved by the FIA Technical Department may be used. Further to the provisions of the Article C18.2.5, the approval of the FIA Technical Department is conditional upon the PU manufacturer, intending to use such parts during a Championship season undertaking not to conclude any **Exclusivity Agreement** (as defined by Article C5.1.30) for the supply of such parts with the supplier of these parts. The approval request form must be sent by the PU Manufacturer to the FIA before the 1st of November of the preceding year.

- C5.3.2** Engine intake air pressure must be less than 4.8 barA at all times. The pressure of the air will be measured by two FIA approved and sealed devices through which all air destined for combustion must flow. These devices must be installed in FIA approved locations situated in the engine intake air system downstream of the charge air cooling system (as described in Article C5.25.2).
- C5.3.3** The axis of the turbocharger shaft must be parallel to Y=0, inboard of Y=25 and at an angle of 0 +/- 1 degree to X=axis.
- C5.3.4** The total mass of the turbocharger (TC) must be no less than 12kg.
- C5.3.5** Referring to Drawing 4 of Appendix C3, the turbocharger compressor and turbine must satisfy the following dimensional constraints. Only compressor and turbine wheels approved by the FIA Technical Department will be allowed:
- The compressor exducer blade outer diameter (A) must lie between 100mm and 110mm. For the avoidance of doubt, no part of the compressor wheel (including blades, hub and any blade/hub fillet radius) can have a diameter more than the upper limit and the maximum diameter of the compressor wheel (including blades, hub and any blade/hub fillet radius) cannot have a diameter smaller than the lower limit.
 - The compressor axial distance from the outside diameter of the inducer blade edge to rear plane of exducer, at its outer diameter (B) must lie between 30mm and 35mm
 - The turbine inducer blade outer diameter (C) must lie between 90mm and 100mm. For the avoidance of doubt, no part of the turbine wheel (including blades, hub and any blade/hub fillet radius) can have a diameter more than the upper limit and the maximum diameter of the turbine wheel (including blades, hub and any blade/hub fillet radius) cannot have a diameter smaller than the lower limit.
 - The turbine axial distance from the outside diameter of the exducer blade edge to forward plane of inducer, at its outer diameter (D) must lie between 35mm and 40mm
 - The maximum distance between the rear of the compressor exducer and the front of the turbine inducer (E) will be 175mm
- C5.3.6** The rotational speed of the turbocharger may not exceed 150,000rpm.
- C5.3.7** The **Compressor Inlet** must extend upstream of any part of any variable geometry device permitted by Article C5.7.
- C5.4 Power unit geometrical constraints and dimensions**
- C5.4.1** The cylinder bore diameter must be 80mm (± 0.1 mm).
- C5.4.2** The cylinder bore spacing must be 101.0 ± 2 mm.
- C5.4.3** No cylinder of the engine may have a geometric compression ratio higher than 16.0. The procedure which will be used to determine this value may be found in the document [FIA-F1-DOC-Cxxx](#).
- C5.4.4** Each cylinder centreline must pass through the crank axis ± 0.1 mm.
- C5.4.5** The crankshaft centre line must lie at Y=0 and Z=90 (± 0.5 mm) and be parallel to the X axis. The **Power Unit** may only transmit torque to the **Gearbox** by means of a single output shaft that must be co-axial with the crankshaft. The output shaft must rotate clockwise when viewed from the front of the car.

- C5.4.6** The crankshaft main **Journal Bearing Diameter**, measured on the crankshaft, must be no less than 44.95mm. The main **Journal Bearing Width** excluding chamfer must be no less than 18.95mm.
- The surface area of the main journal bearing, calculated using all surfaces within 0.06mm of the maximum radial thickness must be no less than 2500mm². This will be verified by design.
- C5.4.7** The crankshaft crank pin **Journal Bearing Diameter**, measured on the crankshaft, must be no less than 41.95mm. The crank pin bearing width excluding the chamfer must be no less than 17.95mm
- The surface area of the crank pin journal bearing, calculated using all surfaces within 0.06mm of the maximum radial thickness must be no less than 2200mm². This will be verified by design.
- C5.4.8** The **Deck Height** must be a minimum of 168mm.
- C5.4.9** The connecting rod length measured between the centre of the crankshaft journal bore and the piston pin bore must lie between 119.5mm and 120.5mm.
- C5.4.10** Each piston must have three piston rings, two compression rings and one oil control ring.
- C5.4.11** The piston pin diameter must lie between 18.0 and 19.0mm.
- C5.4.12** The valve stem diameter must be no less than 4.95mm.
- C5.4.13** The intake valves' head diameter must lie between 32.5mm and 34.5mm. All intake valves must have an identical design.
- C5.4.14** The exhaust valves' head diameter must lie between 27.0mm and 29.0mm. All exhaust valves must have an identical design.
- C5.4.15** For each cylinder, the following three planes are defined (see Drawing 5 of Appendix C-3):
- The "Lateral plane", which passes through the cylinder centreline and is normal to the crank axis
 - The "Longitudinal plane", which passes through both the cylinder centreline and the crank axis
 - The "Transverse plane", which is normal to the cylinder centreline and coincident with the **Top Deck**
- Referring to the above-defined planes, the following conditions apply:
- a. The axes of the two intake valves must intersect the Transverse plane inboard of the Longitudinal plane, and be symmetrically arranged about the Lateral plane
 - b. The axes of the two exhaust valves must intersect the Transverse plane outboard of the Longitudinal plane, and be symmetrically arranged about the Lateral plane
 - c. The spark plug axis must intersect the Transverse plane within a quadrilateral defined by the four intersection points defined in points (a) and (b) above
 - d. The injector axis must lie on the lateral plane, outside the longitudinal plane, and the angle between the injector axis and the cylinder centreline must be 70deg (± 5 deg).
- C5.4.16** All elements of the **Power Unit** specified in the relevant column of the table in Appendix C4 must be installed in the Reference Volumes defined in Appendix C2 and prefixed with **RV-PU-**. Elements must be installed entirely within the relevant Reference Volume. Where Reference Volumes intersect, elements from any of the intersecting volumes will be permitted within the intersection.

Referring to the “REFERENCE VOLUME” column of the Appendix C4:

- a. All the items listed as “**ICE**” must be installed within **RV-PU-ICE**
- b. All the items listed as “**ERS**” must be installed within **RV-PU-ERS**
- c. All the items listed as “**TC**” must be installed within **RV-PU-TC**
- d. All the items listed as “**OT**” must be installed within **RV-PU-OT**

Additionally, the following elements must be installed entirely within **RV-PU-ERS**:

- e. HV connections and **ERS-K Phase Conductors**.
- f. All elements within the **ES Main Enclosure** (defined in Article C5.19.7).

C5.4.17 **Engine (ICE)** mountings may only comprise six M12 studs for connection to the **Survival Cell** and either four or six M12 studs for connection to the **Gearbox Case**. These studs may be fitted on the **Survival Cell, Power Unit** or **Gearbox Case**, their installed end must be M12 and their free end may be a different diameter. Every stud must have a tensile strength greater than 100kN.

The six mounting faces of the studs for connection to the **Survival Cell** must lie at $[X_{PU}, Y, Z]=[0, \pm 270, 25], [0, \pm 360, 270]$ and $[0, \pm 190, 440]$. All six of these studs must be used.

The four mounting faces of the studs for connection to the **Gearbox Case** must lie at $[X_{PU}, Y, Z]=[480, \pm 125, 25]$ and $[480, \pm 265, 360]$. All four of these studs must be used. Optionally, an additional two studs may be used, provided their coordinates are at $[X_{PU}, Y, Z]=[480, \pm 150, 140]$.

A tolerance of +/- 0.2mm will be permitted on all of the above dimensions, all dimensions refer to the centre of the studs. All dimensions in this Article refer to studs fitted symmetrically about the car centre plane.

Any part which provides additional load path, aside from the path through the studs defined above, from the **Survival Cell** to the **ICE** or from the **ICE** to the **Gearbox Case**, is prohibited unless this is incidental to its principal purpose. Furthermore, any such part may provide no greater structural connection between these pairs of assemblies than is reasonable for the safe and reliable fulfilment of its purposes.

C5.4.18 No part of **RV-PU-ERS** that lies above $Z=51$ may lie forwards of **RS-FWD-FUEL-LIMIT**.

[Note: this item may be moved to the Chassis Regulations at a future date.]

C5.5 Mass and centre of gravity

C5.5.1 Depending on where the **MGU-K Mechanical Transmission** (as defined in item 276 of Appendix C4) is located, the overall mass of the **ICE** “PU Mass group” elements as referred to in Appendix C3 must be no less than the values defined below:

- a. If all of the speed ratio of the **MGU-K Mechanical Transmission** is located in the **RV-PU-ERS** the total mass of the **ICE** must be no less than 130.0kg.
- b. If all of the speed ratio of the **MGU-K Mechanical Transmission** is located in the **RV-PU-ICE** the total mass of the **ICE** must be no less than 134.0kg.
- c. If part of the speed ratio of the **MGU-K Mechanical Transmission** is located in both the **RV-PU-ICE** and the **RV-PU-ERS** the total mass of the **ICE** must be no less than 132.0kg.

- C5.5.2** The overall mass of the PU must be a minimum of **185 kg**.
- C5.5.3** The centre of gravity of the **Power Unit** must be above $Z=200$. The parts considered are listed as “**ICE**” and “**TC**” in the “**PU MASS GROUP**” column of Appendix C3, with the exception of items 6 (**ICE** intake air system components), 20 (ICE-mounted electrical components), 29~~8~~ (MGU-K Torque sensor), 30~~29~~ (SCM), 41~~0~~ (Powerbox), 43~~2~~ (General electrical devices outside of the ESME) 44~~9~~ (source of energy independent of the ES), 70~~69~~ (PU air valve regulators) and 71~~0~~ (PU air valve system equipment).
- C5.5.4** The mass of a piston (with piston -pin, piston -pin retainers and piston rings) may not be less than 350g.
- C5.5.5** The mass of a connecting rod (with fasteners, small and big end bearings) may not be less than 320g.
- C5.5.6** The mass of the complete crankshaft assembly between the mid positions of the front and rear main bearing journals (including balance masses, bolts, bungs, O-rings between the boundaries), may not be less than 5800g. See drawing 1 in Appendix C3.
- C5.5.7** When establishing conformity with Articles C5.5~~7~~.1, C5.5~~7~~.2, C5.5~~7~~.3 and Appendix C5, the homologated **Power Unit** perimeter will be defined in accordance with the table shown in Appendix C4~~9~~.
- C5.5.8** **ICE Ballast** may be fitted to the ICE in order to achieve the required mass subject to the following restrictions:
- It must have no function other than to add mass to the **ICE**.
 - The sum of all **ICE Ballast** components will have a maximum mass of 2kg and homologated within a range of +/-~~100~~ 200 gram.
 - ICE Ballast** must be secured in such a way that tools are required for its removal and that it remains immobile with respect to the **Sprung Mass** in its entirety. It must be possible to remove the **Ballast** without breaking seals on any other part of the **ICE**. It should also be possible to affix a FIA security label to the **Ballast** if deemed necessary by the FIA technical delegate.
 - Have a density greater than 7500Kg/m³.
- C5.6 Engine intake air**
- C5.6.1** With the exception of incidental leakage through joints or cooling ducts in the engine intake air system (either into or out of the system), all air entering the engine must enter the bodywork through a maximum of two inlets which are located on a single X plane between $X_C = -850$ and $X_R = -500$ and above $Z=200$.
- Furthermore, any such inlets must be visible in their entirety when viewed from the front of the car without the driver seated in the car and with the secondary roll structure and any parts attached to it removed (see Article C12.4.2).
- C5.6.2** The addition of any substance other than fuel, as described in Article C5.11.3, into the air destined for combustion is forbidden. Exhaust gas recirculation is forbidden.
- C5.6.3** There must be no more than one butterfly or rotating barrel, as described in Article C5.1.33, in the geometrical path of air exiting the **Compressor Outlet** and going to any cylinder.

C5.7 Variable geometry systems

- C5.7.1** With the exception of **Wastegates**, variable geometry exhaust systems are not permitted. No form of variable geometry turbine (VGT) or variable nozzle turbine (VNT) or any device to adjust the gas throat section at the inlet to the turbine wheel is permitted.
- C5.7.2** Variable valve timing and variable valve lift profile systems are not permitted.
- C5.7.3** Moveable **Trumpets** are not permitted, and any geometry conveying the air from the **Compressor Outlet** to the cylinder inlet must be fixed, except the **Throttles** and the pop-off valves.
- C5.7.4** Variable geometry intake device(s) are permitted in the compressor housing.

C5.8 Exhausts

- C5.8.1** With the exception of incidental leakage through joints (either into or out of the system) and **Power Unit** breather fluids, all and only the fluids entering the **Compressor Inlet** and **Fuel Injectors** must exit from the **Engine Exhaust System**.
- C5.8.2** All turbine exit and all **Wastegate** exhaust fluids must pass through the **Exhaust Tailpipe** "tailpipe" defined in Article C3.9.2.
- C5.8.3** ~~A minimum wall thickness of 1.0mm of the exhaust pipe is required for~~ The wall thickness of all exhaust pipes from the **Cylinder Head exhaust flange** to the turbine and **Wastegate** must be a minimum of 1.0mm and will be verified by design. The measured component mass must not be less than 97% of the mass calculated from the homologated CAD model. The procedure which will be used to assess compliance of an **Engine Exhaust System** with this article may be found in the document FIA-F1-DOC-Cxxx.
- C5.8.4** The engine must be equipped with lambda sensors either fitted into each exhaust secondary, one per cylinder bank, or a single lambda sensor fitted into the turbine tailpipe. These lambda sensors must be connected to the **FIA Standard ECU** in a manner specified by the FIA and their measurement must be supplied to the FIA at all times.

C5.9 Fuel systems

- C5.9.1** The pressure of the fuel supplied to the **Fuel Injectors** may not exceed 350barG.
- C5.9.2** There may only be one **Fuel Injector** per cylinder and no **Fuel Injectors** are permitted upstream of the intake valves or downstream of the exhaust valves. Bespoke injector nozzle designs are permitted.
- C5.9.3** All cars must be fitted with a **Fuel Flow Meter**, wholly within the fuel tank. This sensor may only be installed and used as specified by the FIA Technical Department. Furthermore, all fuel delivered to the **Power Unit** must pass through this homologated sensor and must all be delivered to the **Combustion Chambers** by the **Fuel Injectors** described by Article C5.9.2.
- C5.9.4** Homologated sensors which directly measure the pressure and temperature of the fuel supplied to the **Fuel Injectors** must also be fitted, these signals must be supplied to the FIA data logger.

- C5.9.5** Any device, system or procedure the purpose and/or effect of which is to increase the flow rate or to store and recycle fuel after the measurement point is prohibited. Additional measurements in each sub-circuit of the fuel system may be requested in order to check compliance. When fuel flow rate is above 90% of the maximum fuel flow defined in C5.4.3, fuel pressures must remain constant in each sub-circuit.
- C5.9.6** A maximum of 0.25 litres of fuel may be kept outside the **Survival Cell**, but only that which is necessary for the normal running of the engine.
- C5.9.7** The **High pressure fuel pump** may only be driven by one of the camshafts actuating the intake or exhaust valves
- C5.10 Ignition systems**
- C5.10.1** Ignition is only permitted by means of a single **Ignition Coil** and single spark plug per cylinder. No more than one spark per cylinder per engine cycle are permitted.
- C5.10.2** Only conventional spark plugs that function by electrical potential discharge across an exposed gap are permitted.
- Spark plugs are not subject to the materials restrictions described in Articles C15.6 and C15.7.
- C5.10.3** The spark energy per ignition is limited to a maximum of 120.0mJ.
- C5.11 Ancillaries**
- C5.11.1** Unless specified otherwise, **Ancillaries** must be mechanically or electrically driven. Any electrically driven ancillary cannot be linked mechanically to any drivetrain, including the **Power Unit**. **Ancillaries** cannot be used to propel the car.
- C5.11.2** With the exception of batteries of less than 100 kJ total capacity used for safety and control purposes during ERS start-up and shut-down operations, which must be prevented from supplying energy under normal ERS operation; electrical energy may not flow from any ancillary in the direction of any DC pole of the ERS High Voltage DC bus. This must be guaranteed by design and verifiable by inspection.
- C5.11.3** For the **ICE** and the TC, all fuel pumps delivering more than 10 barG, coolant pumps (including pumps used to circulate the fluid(s) which cool the air destined for combustion), oil pumps, scavenge pumps, oil/air separators and hydraulic pumps must be mechanically driven directly from the engine and/or MGU-K with a fixed speed ratio.
- C5.11.4** For the ESME, the MGU-K and the **PU-CE**, all **Ancillaries** (including pumps) may be mechanically or electrically driven
- C5.12 Power unit torque or power demand**
- ~~**C5.12.1** The only means by which the driver may control acceleration torque to the driven wheels is via a single foot (accelerator) pedal mounted inside the **Survival Cell**.~~
- ~~**C5.12.2** Designs which allow specific points along the accelerator pedal travel range to be identified by the driver or assist the driver to hold a position are not permitted.~~
- C5.12.1** At any given engine speed the driver torque demand map must be monotonically increasing for an increase in accelerator pedal position.

- C5.12.2** At any given accelerator pedal position and above 4,000rpm, the driver torque demand map must not have a gradient of less than – (minus) 0.045Nm/rpm.
- C5.12.3** At any given engine speed, the minimum torque in the driver torque demand map must be a negative value greater than the minimum curve defined as Torque (Nm) = $-0.0027 * \text{engine speed (rpm)} - 30$.
- C5.12.4** Except for conforming to Article C5.24.8, the driver maximum power demand cannot be reduced by more than 150kW at the start of any full **Throttle** period and the power reduction will remain fixed for a minimum of 1s.
- C5.12.5** The driver maximum power demand cannot be increased during any full **Throttle** period, except when the overtake mode, as specified in the Appendix to the Regulations, is selected by the driver.
- C5.12.6** The driver maximum power demand must not be reduced at any greater than the rates defined below:
- 50kW in any 1s period at **Competitions** where the FIA determines that the power limited distance exceeds 3500m. These **Competitions** and the vehicle fundamentals used for the calculation of the power limited distance may be found in the document **FIA-F1-DOC-Cxxx**.
 - 100kW in any 1s period at all other **Competitions**.

Furthermore, the total power reduction is limited to a maximum of 450kW and the resulting electrical DC power of the **ERS-K** must remain above –100kW. **These limits are changed respectively to 600kW and -250kW for the Sprint Qualifying and Qualifying sessions.**

- C5.12.7** The electrical DC power of the ERS-K may not be reduced at rates greater than those specified in Article ~~C5.14.8~~ C5.12.6, unless:
- the theoretical MGUK power resulting from reduction at rates equal to those specified in Article ~~C5.14.8~~ C5.12.6 is negative;
 - the **ICE** power is negative and the **ERS-K** power needs to be reduced further to achieve the driver demand;
 - the **ERS-K** power needs to be reduced further to achieve the maximum power permitted by Article C5.24.8;
 - the driver power demand is negative;
 - a gearshift is in progress.
 - car speed is below 210kph.

[**Note:** Further discussions will take place to fully evaluate the benefits and consequences of art. C5.12.7 and whether modifications are necessary, with the aim of preventing by-pass of article C5.12.6 without being too penalising from an energy point of view]

- C5.12.8** Details of the implementation in the **FIA Standard ECU** of the application and monitoring of Article C5.124 may be found in the document **FIA-F1-DOC-Cxxx**.

C5.13 Power unit control

- C5.13.1** The maximum delay allowed, computed from the respective signals as recorded by the **FIA ADR** or **FIA Standard ECU**, between the accelerator pedal position input signal and the corresponding output demands being achieved is 50ms.

C5.13.2 Teams may be required to demonstrate the accuracy of the **Power Unit** configurations used by the **FIA Standard ECU**.

C5.13.3 **Power unit** control must not be influenced by **clutch** position, movement or operation.

C5.13.4 The idle speed control target may not exceed 4,000rpm.

C5.13.5 A number of **Power Unit** protections are available in the **FIA Standard ECU**.

A minimum of nine seconds hold time should be configured for the **power unit** protections enabled during qualifying and **Race**. The configuration of the air tray fire detection and **throttle** failsafe are exceptionally unrestricted in order to allow each team to achieve the best level of safety.

C5.13.6 The **Power Unit** must achieve the torque demanded by the FIA standard software.

C5.13.7 Regulatory torque sensors must be fitted to measure the following output torques:

- a. The PU torque output (Ref Appendix C4 Item 21)
- b. The MGU-K torque output (Ref Appendix C4, item 298)

The installation and the connectivity of each of these torque sensors to the **FIA Standard ECU** must be approved by the FIA.

~~For reference, torque sensors will also be fitted to each driveshaft. These will be defined in future versions of 2026 Technical Regulations that also cover the 2026 car.~~

C5.13.8 Engine plenum air temperature must be more than ten degrees centigrade above ambient temperature. When assessing compliance, the temperature of the air will be the lap average recorded, by an FIA approved and sealed sensor located in an FIA approved location situated in the **Engine Plenum**, during every lap of the **Sprint Qualifying Session**, the **Sprint Session**, the **Qualifying Session**, and the **Race**. The first lap of the race, laps carried out whilst the safety car is deployed, laps with a time at least 20% greater than the fastest lap of the session, pit in and out laps and any laps that are obvious anomalies (as judged by the FIA) will not be used to assess the average temperature. The ambient temperature will be that recorded by the FIA appointed weather service provider. This information will also be displayed on the timing monitors.

C5.13.9 Any pressure sensor used to measure pressure of any fluid necessary to ensure the **Power Unit** functions correctly at all times (including but not limited to coolant, oil, fuel and air) will be classified as a regulatory sensor (reference item 22 Appendix C4).

C5.13.10 With the exception of exhaust temperature sensors and temperature sensors embedded in **Electronic Boxes**, any temperature sensor used to measure temperature of any fluid necessary to ensure the **Power Unit** functions correctly at all times (including but not limited to coolant, oil, fuel and air) will be classified as a regulatory sensor (reference item 22 Appendix C4).

C5.13.11 A maximum of one **Knock Sensor** per cylinder is permitted. This sensor must be an accelerometer-type.

C5.13.12 No sensor of any kind, designed or installed to measure or infer internal cylinder pressure, temperature, or to determine the heat release characteristics will be permitted, with the exception of the standard **Knock Sensors** permitted by Article C5.15.11 with standard signal processing by the **FIA Standard ECU**.

Any other sensor which is incidentally capable of measuring or inferring internal cylinder pressure, temperature, or determining the heat release characteristics must have an attenuation of no less than 40dB above 1kHz at any point in the measurement chain and will be subject to the homologation required by Article 8 (TR 2023).

C5.14 Engine high rev limits

Engine high rev limits may vary for differing conditions provided all are contained within a band of 750rpm. However, a lower rev limit may be used when:

- a. The **Gearbox** is in neutral.
- b. Stall prevention is active.
- c. The driver **Clutch** request is greater than 95% of the total available travel of the driver **Clutch** actuation device, used only to protect the engine following a driver error.
- d. An engine protection is active.
- e. The bite point finder strategy is active.
- f. The safety car is deployed or during the formation lap.

Except for the above conditions, **Power Unit** actuators may not be used to artificially control the **Power Unit** speed or alter the **Power Unit** response in a rev range more than 750rpm below the final rev limit.

C5.15 Starting the engine

The car must be fired up with its on-board system (MGU-K) at any time.

C5.16 Stall prevention systems

If a car is equipped with a stall prevention system, and in order to avoid the possibility of a car involved in an accident being left with the engine running, all such systems must be configured to stop the engine no more than ten seconds after activation.

The sole purpose of such systems is to prevent the engine stalling when a driver loses control of the car. If the car is in second gear or above when the system is activated multiple gear changes may be made to either first gear or neutral, under all other circumstances the Clutch alone may be activated.

Each time such a system is activated the Clutch must be fully disengaged and must remain so until the driver de-activates the system by manually operating the Clutch with a request greater than 95% of the total available travel of the drivers Clutch actuation device.

C5.17 Energy Recovery System (ERS)

C5.17.1 The system will be considered shutdown when no **High Voltage** will be present on the portion of the **HVDC Bus** located on the CU-K side of the ES main contactors, across any capacitor belonging to the CU-K or outside of the RV-PU-ERS.

It must be possible to shut down the ERS by all the following means:

- a. The driver Master Switch required by Article C8.7.1.

- b. The handles required by Article C8.7.2.
- c. The CDS button required by Article C9.3.

The shutdown process must take no longer than two seconds from activation and must be started immediately when the electrical circuits to the ignition are cut off by any of the means described in articles C8.7.1, C8.7.2, or when the CDS, defined in Article 9.5, is activated.

C5.17.2 The ERS must shut down when the **FIA Standard ECU** initiates an anti-stall engine shut off.

C5.17.3 All cars must be fitted with two ERS status lights which:

- a. Have been supplied by an FIA designated manufacturer and fitted to the car in accordance with the instructions in the document **FIA-F1-DOC-Cxxx**.
- b. Are in working order throughout the **Competition**.
- c. Must remain powered for at least 15 minutes following the start of the shutdown process. The **FIA ADR** internal battery will be responsible for power supply to those lights once the ERS is shutdown.
- d. Are marked with a “**HIGH VOLTAGE**” symbol according to ISO3864 of at least 30mm along the triangle side and no more than 50mm away from the lights.

C5.17.4 Placeholder for an article pre-approved for 2027.

~~All cars must be fitted with one ERS Status Buzzer unit which:~~

- ~~a. Have been supplied by an FIA designated manufacturer and fitted to the car in accordance with the instructions in the document **FIA-F1-DOC-Cxxx**.~~
- ~~b. Are in working order throughout the **Competition**.~~
- ~~c. Remains powered for at least 15 minutes following the start of the shutdown process. The **FIA ADR** internal battery will be responsible for the power supply to the unit once the ERS is shutdown.~~

C5.17.5 All cars must provide signals regarding the current car operating safety status to the **FIA ADR** in order to facilitate control of the ERS status lights ~~and ERS Status Buzzer unit~~. The status of the car must be based at least on the insulation measurement, cells voltage, cells temperature, contactors and the systems defined in C5.23.4. The systems which provide these signals managed by the **BMS** must remain powered and working 15min after the shutdown process has been started. They must be connected to a source of energy independent of the ES and ensure that these systems remain powered in the event of reasonably foreseeable ES issues.

C5.17.6 The **Maximum Working Voltage** on the car must never exceed 1000V.

C5.17.7 The following elements of the **Power Unit** must be fitted inside the **ES Main Enclosure** installed within the ERS Reference Volume (RV-PU-ERS):

- a. ES elements as defined in items 354 (ES) and 387 (HV elements) of Appendix C4.
- b. The HV safety elements and sensors defined in items 365 (DC sensor, IMD) and 376 (safety devices) of Appendix C4.
- c. The **DC-DC Unit** and its connection to the ES **HV DC bus**. Includes active parts, enclosure, brackets and supports.

- d. CU-K. Includes active parts, enclosure, brackets and supports.
- e. HV DC connections between ES and CU-K/**DC-DC Unit**. Includes all conductors, insulation, EMC screening, mechanical and thermal shielding.

C5.17.8 In addition to the components listed in Article C5.19.7, the following elements may also be fitted within the **ES Main Enclosure**:

- a. Low voltage Power Distribution Board (PDB).
- b. PU Electric pump Driver units and non **ICE**-mounted ERS cooling systems as defined in item 598 of Appendix C4.
- c. Low Voltage systems passive protection devices - Fuse box.
- d. Low Voltage looms exclusively used: for **PU** functionalities or power supply to non-PU devices.
- e. General electrical devices exclusively used for **PU** functionalities, as defined in item 424 of Appendix C4

With the exception of wiring or any mechanical supports for these components, no additional elements may be fitted in the **ES Main Enclosure**.

C5.17.9 The minimum mass for the **ES Main Enclosure** PU Mass group elements as defined in Appendix C4 is 35.0kg. The procedure which will be used to determine this value may be found in the document [FIA-F1-DOC-Cxxx](#).

C5.17.10 Any significant debris resulting from a failure of the elements located inside the RV-PU-ERS and defined in Appendix 3 items 265 (MGU-K) and 276 (MGU-K mechanical power transmission) must be contained by and within the housing(s) hosting those parts. Documents demonstrating compliance with this requirement must be part of the PU Manufacturer homologation dossier. Additional guidance may be found in the document [FIA-F1-DOC-Cxxx](#).

C5.18 MGU-K

C5.18.1 The MGU-K must be mechanically fixed to the **Survival Cell**, the **ICE** or both.

C5.18.2 Under normal operating conditions all MGU-K rotating parts must be permanently mechanically linked to the **ICE** with a fixed speed ratio to the crankshaft. The MGU-K and its drive axis must be parallel to the crankshaft axis.

C5.18.3 All mechanical power to and from the MGU-K must pass through a single shaft to the MGU-K transmission. The connection to the **ICE** crankshaft must be ahead of $X_{PU}=100$.

C5.18.4 An in-line, passive, dissipative energy torque limitation device may be incorporated in this link which temporarily allows the speed ratio to change for the sole purpose of protecting the components from dynamic torque overshoots. This device may only act above 520Nm when referred to crankshaft speed.

C5.18.5 The relative rotational speed between any two parts of the MGU-K may not exceed 60,000rpm.

C5.18.6 The thickness of the stack magnetic soft alloy laminated sheets may not be less than 50µm.

C5.18.7 Depending on where the **MGU-K Mechanical Transmission** is located, the total mass of the MGU-K "PU Mass group" elements as referred to in Appendix C4 must be no less than the values defined below:

- a. If all of the speed ratio of the **MGU-K Mechanical Transmission** is located in the RV-PU-ERS the total mass of the MGU-K must be no less than 20.0kg.
- b. If all of the speed ratio of the **MGU-K Mechanical Transmission** is located in the RV-PU-**ICE** the total mass of the MGU-K must be no less than 16.0kg.
- c. If part of the speed ratio of the **MGU-K Mechanical Transmission** is located in both the RV-PU-**ICE** and the RV-PU-ERS the total mass of the MGU-K must be no less than 18.0kg.

The total mass of item 298 (MGU-K torque sensor) and item 318 (K torque sensor shaft and mechanical connection between MGU-K and **ICE**) must be allocated to either the MGU-K or the **ICE** to assess compliance with this article and article C5.57.1.

C5.18.8 All rotating parts of the MGU-K and its mechanical transmission must have a fixed inertia by design. Any system other than that permitted by article C5.1826.4, the effect of which is to vary the inertia, is prohibited.

C5.18.9 The elements defined in item 318 (MGU-K torque sensor shaft) of Appendix C4 must be dismountable from their respective PU elements without breaking any FIA permanent seal.

C5.19 Energy Store

C5.19.1 Only cells approved by the FIA Technical Department may be used in the ES. Subject for provision of the Article C18.2.5, the approval of the FIA Technical Department is conditional upon the PU manufacturer, intending to use such parts during a Championship season undertaking not to conclude any **Exclusivity Agreement** (see definition article C5.1.30) for the supply of such parts with the supplier of these parts. The approval request form must be sent by the PU Manufacturer to the FIA before the 1st of November of the preceding year.

C5.19.2 Solely a single specification of cell may be homologated, including the same exiting position of the cell connection terminals (**Cell Tabs** - Article C5.2.26). The **Cell Tabs** may have different shapes for integration purposes inside the ES.

C5.19.3 Any non-ERS energy storage and components supplied by it will be considered an ancillary and subject to Article C5.13.1.

C5.19.4 A diode must be fitted, in series, at the DC-DC Unit positive high voltage pole to ensure that electrical energy cannot flow from the DC-DC Unit into the ES. This must be guaranteed by design and verifiable by inspection.

C5.19.5 The **DC-DC Unit HV DC Bus** branch must have a **DC-DC Unit** fuse, and, additionally, **DC-DC Unit** relay(s) if connected on the ES side of the ES Main contactors. Those protective devices will insulate the **DC-DC Unit** from the **HV DC Bus** DC+ and DC- poles and protect the installation in case of short circuit.

The **DC-DC Unit** relay(s) must provide a dielectric strength:

- a. between the relay control circuit and any of the **High Voltage** contacts and;
- b. across **High Voltage** contacts, when the **High Voltage** circuit is open.

For each of (a) and (b) above:

- c. A dielectric withstanding voltage test must be performed with a DC voltage at least equal to the ES maximum DC voltage plus 1200V. The device must withstand the DC voltage for 60

seconds with a leakage current lower than 1mA and without flashover. The test must be performed on both HV terminals polarities if solid-state relays are used.

- d. The electrical resistance measured by applying a DC voltage of 500VDC when the circuit is open must be higher than 50MΩ.

Once commanded to open, the **DC-DC Unit** relays must be able to keep the **DC-DC Unit** insulated from the ES **HV DC Bus** branch.

C5.19.6 With the exception of the ES safety systems, the **ES Cells** defined in C5.2.25 are the only energy storage source allowed in the ES.

C5.20 ES design and installation

C5.20.1 **High Voltage** must not be present or accessible by any reasonable means between the **ES Main Enclosure** and any ES off-board charging connector when the off-board charger is not connected.

C5.20.2 No **High Voltage** is permitted outside of the RV-PU-ERS, except:

- a. For the **High Voltage** inside the power box where the boost converter can generate up to 80V DC.
- b. When an off-board charger is connected to charge or discharge the ES.

C5.20.3 The ES must be equipped with a **BMS** which:

- a. Must detect internal faults and must trigger power reduction delivered from/to the battery or shutdown the ERS if it considers that the ES is operating unsafely.
- b. Must be capable of reducing the voltage dispersion between each cell to its minimal level without breaking any FIA seal.
- c. Must only be capable of consuming energy and cannot transfer energy from any **PU-CE** into the ES. This must be guaranteed by design and verifiable by inspection.

C5.20.4 The ES must be equipped with a fuse to protect the system in case of a short circuit. The fuse shall be located as close as possible to the cells.

The fuse must be tested and demonstrated to work in realistic load cases.

C5.20.5 The ES must have at least two contactors, one per positive and negative pole. Those ES main contactors must insulate the CU-K from the **High Voltage** parts of the ES once the shutdown process is completed.

Contactors must provide a dielectric strength:

- a. between the contactor's control circuits and any of the **High Voltage** contacts and;
- b. across **High Voltage** contacts, when the **High Voltage** circuit is open.

For each of (a) and (b) above:

- c. A dielectric withstanding voltage test must be performed with a DC voltage at least equal to the ES maximum DC voltage plus 1200V. The device must withstand the DC voltage for 60 seconds with a leakage current lower than 1mA and without flashover.
- d. The electrical resistance measured by applying a DC voltage of 500VDC when the circuit is open must be higher than 50MΩ.

Once commanded to open, contactors must be able to keep the **High Voltage** circuit open.

The contactors must be tested and demonstrated to work in realistic load cases, as described in the document [FIA-F1-DOC-Cxxx](#).

- C5.20.6** Only Fuses and Contactors for ERS application approved by the FIA Technical Department will be accepted. The approval of the FIA Technical Department is conditional upon such parts being available on a non-exclusive basis and under normal commercial terms to all **F1 Teams**. The approval request form must be sent by the component supplier to the FIA before the 1st of November of the year preceding the year of introduction.
- C5.20.7** In addition to the contactors mentioned in C5.20.5, the ES HV DC+ and DC- poles must be capable of being isolated from the **PU-CE** (~~C5.2.10~~) consumers by means of a manual action(s). The operator must be able to perform the manual operation(s) before opening any **ERS-K Phase Conductors** connection or interface giving access to **Live Parts** while the ERS is fitted to the car.
- C5.20.8** Interfaces must be present on the ESME and may be present on the MGU-K to allow the connection of the **ERS-K Phase Conductors** between the ESME and the MGU-K. Should such interfaces not be present on the MGU-K then the parts that fulfil the function of the **ERS-K Phase Conductors** will be considered to be part of the MGU-K.
- C5.20.9** The **ES Main Enclosure** must be equipped with a gas evacuation system which in case of **ES Cell(s)** venting or electronic components explosion prevents irreversible mechanical damage to the ESME. The design and operating conditions of such a system are of responsibility of each PUM and must be detailed in their respective FMEA. This venting system must be approved by the FIA Technical Department before the 21st of March of the year preceding the year of introduction.
- C5.20.10** The **ES Main Enclosure** material(s) must satisfy a minimum fire protection equivalent of UL94 V0 unless the **ES Cells** are proven to not be susceptible to self-heating phenomenon. A document demonstrating compliance with this article must be included in the PU Manufacturer homologation dossier. Guidance on how to demonstrate that **ES Cells** aren't prone to thermal runaway behaviour may be found in the document [FIA-F1-DOC-Cxxx](#).
- C5.20.11** The ES must have only two poles, the ES HV DC+ and ES HV DC-, that are connected to the **HV DC Bus**. Additionally, the CU-K, the **DC-DC Unit** and any other **PU-CE** may only be connected to the **HV DC bus** via the ES HV DC+ and ES HV DC- poles.

C5.21 ERS General electrical safety

C5.21.1 Principles

- a. A single point of failure of the electric system or ERS cannot result in a person being exposed to a **Live Part**.
- b. The components used cannot cause injury under any circumstances or conditions, whether during normal operation or in reasonably foreseeable cases of malfunction.
- c. If a single fault can predictably generate multiple failures, they must be considered as a single point of failure.

C5.21.2 Protection of cables, lines, connectors, switches, electrical equipment

The following design practices must be adhered to for all electrical parts external to the **ES Main Enclosure** or accessible and which operate at **High Voltage**:

- a. Protection against electrical shock via **Basic Insulation** combined with equipotential bonding, **Double Insulation** or **Reinforced Insulation**
- b. Protection against risks of mechanical damage
- c. Parts should be secured with cable guides, enclosures and conduits if exposed to stress (mechanical, vibration, thermal)
- d. Each cable must be rated to the respective circuit current and must be insulated adequately for the environment and operating conditions
- e. Sections of looms containing **High Voltage** wiring must be coloured orange
- f. Connectors must be IP2X when not connected and IP65 when mated
- g. A connector plug must physically only be able to mate with a single correct socket of any sockets within reach
- h. Comply with creepage and clearance distances according to IEC-60664. Connectors which are opened in the garage must be considered PD3 or higher. Clearance and creepage requirements can be verified by safety tests proposed in IEC-60664-1 session 6.
- i. If, under the provisions of Article C5.20.1, the MGU-K is fixed to the **ICE**, the PU manufacturer must provide proof that the **ERS-K phase conductors** and connectors would not lead to exposed **High Voltage** in case of foreseen damage conditions.

C5.21.3 The **ES Main Enclosure**, MGU-K and any HV box residing outside the **ES main enclosure** must be marked with a “Danger High Voltage” symbol according to ISO 7010. In addition to that, **at least 70% of the ES Main Enclosure external surface** must be orange coloured.

C5.21.4 All ERS **High Voltage** conductors outside of the **ES Main Enclosure** must be equipped with:

- a. A system to prevent **High Voltage** on the CU-K side of the ES contactors when **ERS-K Phase Conductors** are not connected or incorrectly mated. In the event of detection of any of those conditions, actions must be immediately taken to ensure safe operation. The list of actions must be pre-defined in a Failure Mode and Effect Analysis provided to the FIA by each **F1 Team**. To avoid spurious detections a software debounce of maximum one second may be used.
- b. A system to allow detection of insulation faults or damaged **High Voltage** lines by an isolation monitoring device.

C5.21.5 To mitigate the risk failure mode where a **High Voltage** is AC coupled onto the car’s low voltage system, bonding is required for any system component to which a wire, cable or harness connects, or passes in close proximity, and which is able to conduct current by means of AC coupling.

The bonding must protect against short circuit currents generated by an insulation failure and low currents generated by capacitive coupling. It can be achieved using wires or conductive parts of an appropriate dimension.

Any components that require equipotential bonding will be connected to the **Car Main Ground** and the resistance of potential equalization paths must not exceed 5.0 Ω .

In addition, the resistance measured between any two **Exposed Conductive Parts** of the high voltage system must not exceed 0.1 Ω .

C5.21.6 An insulation monitoring device must be used to measure the insulation resistance between the **Car Main Ground** and the entire conductively connected **High Voltage** system. The insulation monitoring device (reference item 365 Appendix C4) will be used as the primary source of measurement and the DC sensor connected to the ES **High Voltage** negative DC pole as a backup source. They must be connected on the ES side of the contactors.

C5.21.7 The UN38.3 **Energy Store** transportation certification must be shared with the FIA during the homologation of each **Energy recovery system** specification.

~~C5.22 Replacing power unit parts~~

~~Refer to the Article B2.1.10.~~

C5.22 Oil and coolant systems and charge air cooling

C5.22.1 Coolant Header Tanks

Any header tank used on the car must be fitted with an FIA approved pressure relief valve which is set to a maximum of 3.75 barG, details of the relief valve may be found in the document **FIA-F1-DOC-Cxxx**. If the car is not fitted with a header tank, an alternative position must be approved by the FIA.

C5.22.2 Cooling Systems

The cooling systems of the **Power Unit**, including that of the air destined for combustion, must not intentionally make use of the latent heat of vaporisation of any fluid with the exception of fuel for the normal purpose of combustion in the engine as described in Article C5.944.3.

C5.22.3 Oil Tank

All cars must be fitted with a single **Oil Tank**. Oil, as defined in article C16.1.5, may only be contained by the **Oil Tank** and associated lines, elements defined in item 476 of Appendix C4, **ICE**, oil radiators/heat-exchangers, Turbocharger, MGUK and MGUK transmission.

C5.22.4 Oil Tank Level Measurement

The **Oil Tank** must be fitted with an oil level sensor. The measurement of the oil level in the **Oil Tank** must be supplied to FIA at all times.

C5.22.5 Oil Injection

The use of active control valves between any part of the **PU** and the engine intake air is forbidden.

C5.22.6 The use of an **Auxiliary Oil Tank**, or other forms of oil storage other than the single **oil tank** defined in C5.225.3 is not permitted. Accumulation of oil in other volumes (such as catch tanks) may be deemed acceptable only if incidental.

~~C5.24~~ ~~Component Classification~~

~~05.24.1~~ All components belonging to the **power unit** (PU) are listed in Appendix C4. Their classification (“SSPUG”, “DSPUG”, “LPUG”, “OSPUG”), as defined in Article C18, is listed under column “COMPONENT CLASSIFICATION”.

C5.23 **Single ICE Mode**

The **Power Unit** must be operated in a single **ICE** mode during each competitive lap in all sessions of a **Competition**, with the exception of free practice sessions. All details concerning policing of this article may be found in the document [FIA-F1-DOC-Cxxx](#).

ARTICLE C6: FUEL SYSTEM

Advisory Committee: TAC

Governance: F1 Commission / WMSC

C6.1 Fuel tanks

C6.1.1 The fuel tank must be a single rubber bladder conforming to or exceeding the specifications of FIA Standard FT5-1999, the fitting of foam within the tank however is not mandatory. A list of approved materials may be found in the document [FIA-F1-DOC-C036](#).

C6.1.2 With the exception of the fuel out of the **Survival Cell** permitted under Article C5.9.6, all fuel on board the car must be stored within the following limits:

- a. Ahead of $X_{PU}=0$.
- b. Rearward of **RS-FWD-FUEL-LIMIT**.
- c. Inboard of $Y=450$.

C6.1.3 No fuel bladders shall be used more than 5 years after the date of manufacture.

C6.1.4 All fuel tanks must be fitted with a pressure relief valve to prevent overpressure, and with a fuel tank pressure sensor as specified in the diagram of Article C6.6.4. The FIA may request **F1 Teams** to demonstrate that the specification of all relevant parts of the fuel tank, and the strength of the surrounding structure, are consistent with the pressure that the pressure relief valve is set to.

C6.1.5 The maximum internal pressure exerted on the fuel bladder must not exceed 1.0 barG.

C6.2 Fittings and piping

C6.2.1 The total area of apertures in the fuel bladder must not exceed 35 000mm².

Circular apertures smaller than 35mm diameter may be closed with a fitting, secured with a single threaded fastener on the full diameter of the opening, provided that this threaded fastener is provided with mechanical secondary locking.

All other apertures in the fuel bladder must be closed by hatches or fittings which must:

- i. Be secured to metallic bolt rings bonded to the inside of the bladder.
- ii. Have bolt hole edges no less than 5mm from the edge of the bolt ring, hatch, or fitting.
- iii. Attach directly to the fuel bladder and have no part of the **Survival Cell** structure included in the closure.
- iv. Be secured with multiple fasteners in such a way that the absence of any single fastener does not compromise the security of the closure.

C6.2.2 Where the fuel bladder is attached to the **Survival Cell**, fixings must be designed so that if it is pulled away from the **Survival Cell**, the attachment will fail without compromising the integrity of the fuel bladder. For this assessment, the pull-out load for any fitting will be calculated from the clamp area between the fitting and the bladder (on one face of the bladder). Between a clamp area of 1650mm² and 9 500mm², the load will be a linear interpolation between points (1650mm², 11kN) and (9 500mm², 37.5kN). Below a clamp area of 1650mm², the load will be taken as 11kN. Above a clamp area of 9 500mm², the load will be taken as 37.5kN. No fitting may have a clamp area of less than 600 mm².

- C6.2.3** All fuel lines between the fuel tank and the engine must have a self-sealing breakaway valve. This valve must separate at less than 50% of the load required to break the fuel line fitting or to pull it out of the fuel tank.
- C6.2.4** No lines containing fuel may pass through the **Cockpit**.
- C6.2.5** All lines must be fitted in such a way that any leakage cannot result in the accumulation of fuel in the **Cockpit**.
- C6.2.6** All components containing fuel at a pressure greater than 10barG must be located outside the fuel tank.

C6.3 Fuel tank fillers

Fuel tank fillers must not protrude beyond the bodywork. Any breather pipe connecting the fuel tank to the atmosphere must be designed to avoid liquid leakage when the car is running, and its outlet must not be less than 250mm from the Cockpit opening.

All fuel tank fillers and breathers must be designed to ensure an efficient locking action which reduces the risk of an accidental opening following a crash impact or incomplete locking after refuelling.

C6.4 Refuelling

- C6.4.1** A cover must be fitted over any refuelling connector at all times when the car is running on the track. The cover and its attachments must be sufficiently strong to avoid accidental opening in the event of an accident.
- C6.4.2** The fuel in a car must not be colder than the lowest of: ten degrees centigrade below ambient temperature, or ten degrees centigrade, at any time when the car is running after leaving the **F1 Team's** designated garage area.

When assessing compliance:

- a. The ambient temperature will be that recorded by the FIA appointed weather service provider one hour before any practice session or three hours before the **Race** or **Sprint Session**, and will be displayed on the timing monitors.
- b. The temperature of the fuel (TFFMFuel) will be that recorded in the car by the **Fuel Flow Meter**.

- C6.4.3** The use of any device on board the car to decrease the temperature of the fuel is forbidden.
- C6.4.4** Fuel may not be added to nor removed from a car during a **Race**.
- C6.4.5** Any refuelling procedure must respect the provisions of Article B.1.6.9.

C6.5 Fuel draining and sampling

- C6.5.1** **F1 Teams** must provide a means of removing all fuel from the car.
- C6.5.2** **F1 Teams** must ensure that a 0.70 litre sample of fuel may be taken from the car at any time during the **Competition**.

After a practice session, if a car has not been driven back to the pits under its own power, it will be required to supply the above-mentioned sample plus the amount of fuel that would have been consumed to drive back to the pits. The additional amount of fuel will be determined by the FIA.

- C6.5.3** It must be possible to take a fuel sample drawn from the fuel collector as defined in the fuel system hydraulic schematic shown in Article C6.6.4. To facilitate fuel sampling the car must be equipped with a - Parker Stratoflex Slide-Lok -2 Nipple or the **F1 Team** must provide a suitable adaptor to connect an alternative fitting to this format. If an electric pump on board the car cannot be used to remove the fuel an externally connected one may be used provided it is evident that a representative fuel sample is being taken. If an external pump is used it must be possible to connect the FIA sampling hose to it and any hose between the car and pump must be –3 in diameter and not exceed 2m in length. Details of the fuel sampling hose may be found in the document [FIA-F1-DOC-Cxxx](#).
- C6.5.4** The sampling procedure must not necessitate starting the engine or the removal of bodywork (other than the nosebox assembly and the cover over any refuelling connector).
- C6.6 Fuel System Hydraulic Layout**
- C6.6.1** Parts listed in Appendix C6 sections 6A and 6E are classified as OSC.
- C6.6.2** The primer pump(s) and **Fuel Flow Meter** are SSC, the **High Pressure Fuel Pump** and the pressure and temperature sensors are SSPUC; as mandated by the FIA and specified in the document [FIA-F1-DOC-Cxxx](#).
- C6.6.3** All flexible pipes and hoses and their fittings between the primer pump and the **High Pressure Fuel Pump** are SSC, as mandated by the FIA. The specification and permitted lengths are given in the document [FIA-F1-DOC-Cxxx](#). Rigid pipes and manifolds and their fittings may be used instead of flexible pipes and hoses up to the inlet of the **Fuel Flow Meter**.
- C6.6.4** The hydraulic layout of the fuel system must functionally conform to the schematic given in the drawing below. Additional components (such as collector pressurisation system) are permitted, subject to the approval of the FIA if they are deemed necessary for the proper behaviour of the system.

Furthermore, fuel cell components, such as fuel cell pressurisation system and fill/drain hoses, are permitted provided they do not functionally interfere with the system shown.

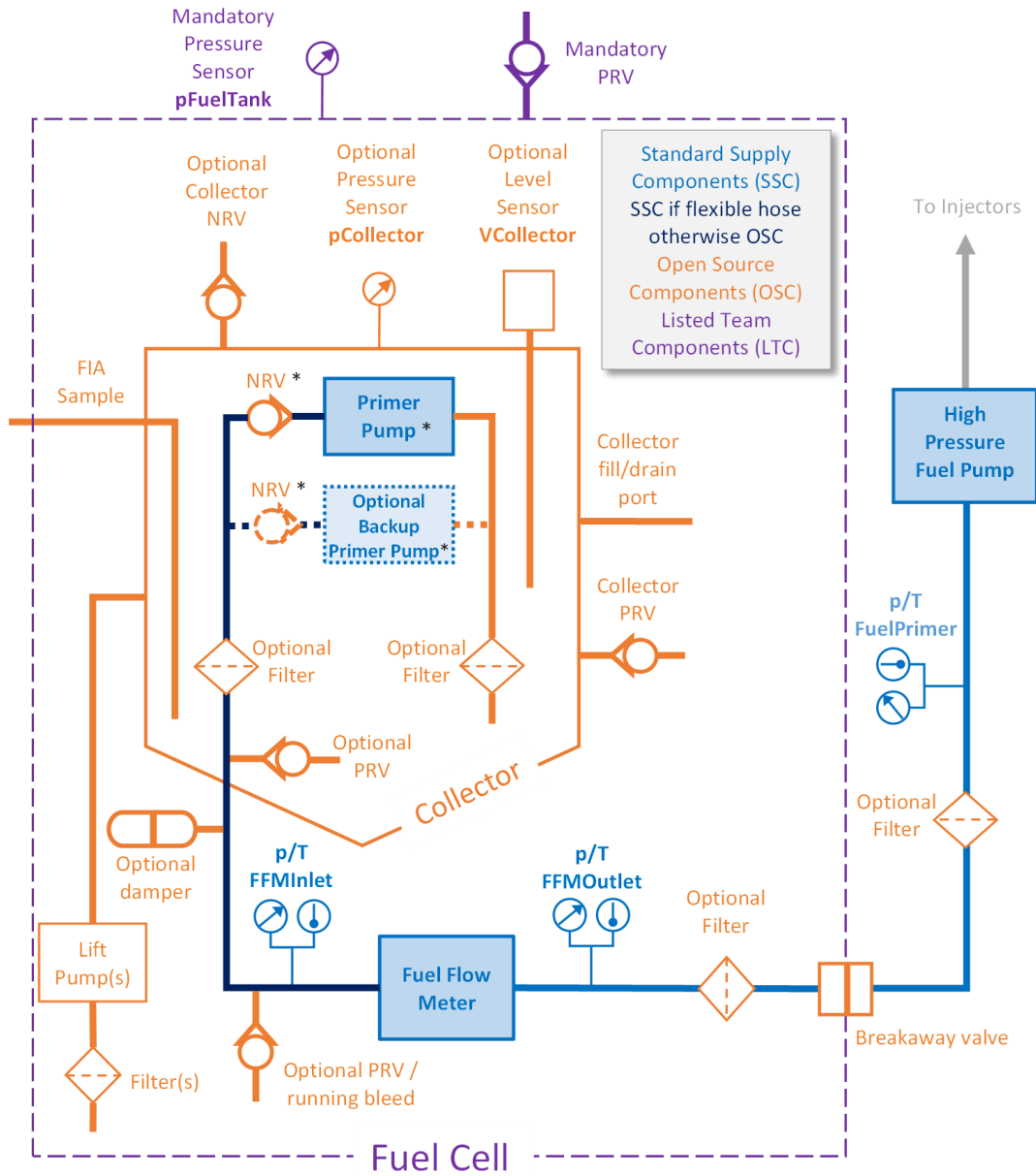

C6.6.5 If a fuel pressure damper is fitted it must be fitted upstream of the **Fuel Flow Meter** described in article C5.9.3.

- C6.6.6** The pressure of the fuel inside the collector may be increased relative to the pressure in the fuel cell volume by the lift pumps and/or either:
- air pressure acting on the free surface of the fuel,
 - or hydraulic oil or air pressure acting on a piston.

In all cases the increase in pressure in the collector must be for the sole purpose of maintaining the primer pump(s) inlet pressure above the cavitation point. And it must be demonstrated to the satisfaction of the FIA that any fluid used for this purpose cannot be used to change the composition of the fuel.

* The primer pump(s), the NRV(s), the damper, the filter and PRV downstream of the NRV(s) may be installed inside or outside the Collector.

ARTICLE C7: OIL AND COOLANT SYSTEMS AND CHARGE AIR COOLING

Advisory Committee: TAC

Governance: F1 Commission / WMSC

C7.1 Location of lubricating oil tanks

All oil storage tanks must be situated between $X_F=0$ and $X_{DIF}=150$, and must be no further outboard than the lateral extremities of the **Survival Cell**.

C7.2 Location of lubricating oil system

No other part of the car containing lubricating oil may be situated behind $X_{DIF} = 150$ or outboard of $Y=750$.

C7.3 Oil and coolant lines

C7.3.1 No lines containing coolant or lubricating oil may pass through the **Cockpit**.

C7.3.2 All lines must be fitted in such a way that any leakage cannot result in the accumulation of fluid in the **Cockpit**.

C7.3.3 No hydraulic fluid lines may have removable connectors inside the **cockpit**.

C7.4 Heat exchangers**C7.4.1 Primary heat exchanger specification and technology**

For **Primary Heat Exchangers** used on the car, the following restrictions apply:

- a. The **Heat Exchanger Core** and header tanks must be made from aluminium alloy.
- b. The **Heat Exchanger Core** must not be produced using additive manufacturing.
- c. **Heat Exchanger Tubes** must have a wall thickness of at least 0.18mm.
- d. The internal cross section of any **Heat Exchanger Tube** must have an area of at least 10mm², without considering structural stiffening ribs and the internal fins described in point (e) below.
- e. **Heat Exchanger Fins** fitted inside the tubes must have a thickness of at least 0.06mm. **Heat Exchanger Fins** fitted between the tubes must have a minimum thickness of 0.05mm.

C7.4.2 Secondary heat exchanger specification and technology

Secondary Heat Exchangers must be constructed from metallic materials with the exception of any sealing or bonding.

ARTICLE C8: ELECTRICAL SYSTEMS*Advisory Committee: TAC**Governance: F1 Commission / WMSC***C8.1 Software and electronics inspection**

C8.1.1 Prior to the start of each season the complete electrical and electronic system on the car must be examined and all on board and communications hardware and software must be inspected by the FIA Technical Department.

C8.1.2 The FIA must be notified of any changes prior to the **Competition** at which such changes are intended to be implemented.

C8.1.3 All re-programmable devices must have a mechanism that allows the FIA to accurately identify the software version loaded.

Acceptable solutions to verify the programmed software may be found in the document **FIA-F1-DOC-Cxxx**.

C8.1.4 All electronic units containing a programmable device, and which are intended for use at a **Competition**, must be presented to the FIA before each **Competition** in order that they can be identified.

C8.1.5 All on-car software versions must be registered with the FIA before use.

C8.1.6 The FIA must be able to test the operation of any compulsory electronic safety systems at any time during a **Competition**.

C8.1.7 **F1 Teams** may only run custom software that has been homologated by the FIA for their control applications hosted inside or outside the ECU described in Article C8.1.1.

Details of the homologation process can be found in the document **FIA-F1-DOC-Cxxx**.

C8.1.8 The number of versions used in any single championship season will be limited as shown in the table below. Figures are given per custom control application.

	2026 See Note 1	2027	2028	2029	2030
ECU F1 Team applications	5	4	3	3	3
ECU PU applications	5	4	3	3	3
ERS and PU-CE Applications	5	4	3	3	3

A version will be deemed to have been used once the car's timing transponder has shown that it has left the pit lane.

Changes made solely for reliability, bug fix, compatibility with standard or other custom applications or changes requested by the FIA will not increase the version counter.

Note 1: for the 2026 Championship season only, the limits defined in the above table will apply starting from the fifth **Competition**.

C8.2 Control electronics

C8.2.1 All components of the **Power Unit**, fuel system, transmission systems, brake system, tyre pressure monitoring system and adjustable bodywork in addition to all associated actuators, must be controlled by the **FIA Standard ECU**.

The **FIA Standard ECU** may only be used with FIA approved software and may only be connected to the control system wiring loom, sensors and actuators in a manner specified by the FIA.

Additional information regarding the **FIA Standard ECU** software versions and setup may be found in the document [FIA-F1-DOC-Cxxx](#).

C8.2.2 All ECUs, control sensors, actuators and FIA monitoring sensors will be homologated by the FIA. Details of the homologation process may be found in the document [FIA-F1-DOC-Cxxx](#).

Each and every component of the control system will be sealed and uniquely identified and their identities tracked through their life cycle.

These components and units may not be disassembled or modified in any way and seals and identifiers must remain intact and legible.

C8.2.3 The control system wiring loom connectivity must be approved by the FIA.

All wiring looms must be built to ensure that each control sensor and each control actuator is electrically isolated from logging-only sensors.

In general, there must be no active or passive electronic component in the control loom. Exceptions (e.g. termination resistors) must be approved by the FIA before use.

Additional wiring guidelines may be found in the document [FIA-F1-DOC-Cxxx](#).

C8.2.4 If sensor faults or errors are detected by the driver or by the on-board software, back-up sensors may be used and different settings may be manually or automatically selected. However, any back-up sensor or new setting chosen in this way must not enhance the performance of the car. Any driver default turned on during the start lockout period may not be turned off before the end of that period.

C8.2.5 Pneumatic valve pressure may only be controlled via a passive mechanical regulator or from the **FIA Standard ECU** and its operation will be monitored by the **FIA Standard ECU**.

C8.3 Start systems

C8.3.1 Any system, the purpose and/or effect of which is to detect when a race start signal is given, is not permitted.

C8.3.2 **The FIA Standard ECU** will implement a “lockout” period after each race start or pit stop during which a number of **Power Unit** and transmission related functions will be frozen or disabled. Details of the strategy may be found in the document [FIA-F1-DOC-Cxxx](#).

C8.4 Data acquisition

C8.4.1 To assist scrutineering, the FIA requires unlimited access to the following FIA Standard ECU information before, during and after any track session:

- a. Application parameter configurations.

- b. Logged data and events.
- c. Real-time **Telemetry** data and events.

Throughout the **Competition**, the logging memory and events buffer may only be cleared by an FIA engineer.

The FIA must have the ability to connect to the **FIA Standard ECU** via an **F1 Team**–provided standalone equipment using an FIA laptop. The **F1 Teams** should make a jump battery available at all times during the **Competition**.

The **F1 Teams** should transfer the real-time **Telemetry** data and events on the FIA network as requested by, and in the format defined by, the FIA.

Prior to the **Race** or **Sprint Session**, the **FIA Standard ECU** data logger must be configured in such a way that allows logging of data for at least two hours and fifteen minutes without exceeding the size of the logger memory.

C8.4.2 Any data acquisition system, **Telemetry** system or associated sensors additional to those provided by the **FIA Standard ECU** and **FIA ADR** must be physically separate and electrically isolated from any **Control Electronics** with the exception of:

- a. The primary regulated voltage supply.
- b. The car system ground.
- c. Communication links to the **FIA Standard ECU**, **Telemetry** unit and **FIA ADR**.
- d. Power supplies, provided they are not used to power any **Control Electronics**, control sensors or actuators.
- e. Time synchronisation lines.
- f. **Power Unit** synchronisation lines.
- g. An umbilical loom whose connector will remain disconnected when the car is moving.

Unless approved by the FIA, no junction box or break-out box may be shared between the **FIA Standard ECU** system and an **F1 Team** data acquisition system.

The use of any coupling, be it hard wired, magnetic, optical or other such link which allows the transmission of signals will not be considered as adequate isolation in the context of this Article.

C8.5 Telemetry

C8.5.1 All cars must be fitted with a car to **F1 Team Telemetry** system which has been manufactured by the FIA designated supplier to a specification determined by the FIA.

C8.5.2 **Telemetry** systems must operate at frequencies which have been approved by the FIA.

C8.5.3 **F1 Team** to car **Telemetry** is prohibited, with the exception of:

- a. The FIA Marshalling System defined in Article C8.11;
- b. Handshaking required by the car to **F1 Team** telemetry system defined in Article C8.5.1.

C8.6 Driver inputs and information

C8.6.1 With the exception of voice radio communication, all signals associated with driver information and driver input devices must be generated by the **FIA Standard ECU**.

C8.6.2 Any single input device, including but not limited to switch, button, paddle or pedal, used by the driver must be connected to a single analogue or digital input of the **FIA Standard ECU**.

Exceptions will be considered to handle the following:

- a. A spare **clutch** paddle sensor.
- b. A spare accelerator pedal sensor.
- c. A separate "kick-down" sensor which indicates that the accelerator pedal has been deliberately depressed past full travel.
- d. Multiplexed shift signals.
- e. A spare brake pressure and pedal sensor.

Any interface between such driver input devices and the **FIA Standard ECU** must be approved by the FIA.

C8.6.3 Any alteration of the driver's inputs may only be commanded by direct, deliberate and primary driver actions.

The logged raw signals from the **FIA Standard ECU** inputs must provide a true representation of the driver's actions.

C8.6.4 Accelerator Pedal

The only means by which the driver may control acceleration torque to the driven wheels is via a single foot (accelerator) pedal mounted inside the **Survival Cell**.

~~Designs which allow specific points along the accelerator pedal travel range to be identified by the driver or assist the driver to hold a position are not permitted.~~

The design or installation of any component, surface finish, or feature, the purpose or effect of which allow specific points between the 0% and 100% calibrated references of the accelerator pedal travel range to be identified by the driver or to assist the driver to hold a position are not permitted.

C8.7 Master switch

C8.7.1 The driver, when seated normally with the safety belts fastened and the steering wheel in place, must be able to cut off the electrical circuits to the ignition, all fuel pumps and the rear lights by means of a spark proof circuit breaker switch.

This switch must be located on the dashboard and must be clearly marked by a symbol showing a red spark in a white edged blue triangle.

C8.7.2 There must also be two exterior horizontal handles which are capable of being operated from a distance by a hook. These handles must be situated at the base of the main roll over structure on both sides of the car and have the same function as the switch described in Article C8.7.1.

The handles must enclose a circle of diameter 40mm and be red or yellow if the surrounding bodywork is predominantly red.

The handles must be marked with a letter "E" in red at least 80mm tall, with a line thickness of at least 8mm, inside a white disc of at least 100mm diameter with a red edge with a line thickness of at least 4mm.

C8.8 Driver radio

C8.8.1 All cars must be fitted with a voice radio communication system which has been manufactured by the FIA designated supplier to a specification determined by the FIA.

C8.8.2 Other than authorised connections to the **FIA Standard ECU**, any voice radio communication system between car and pits must be stand alone and must not transmit or receive other data. All such communications must be open and accessible to both the FIA and broadcasters.

C8.9 Accident analysis

For the purpose of accident analysis and driver rescue, during each **Competition** and all tests which are attended by more than one **F1 Team**, each car must be fitted with:

- a. One **FIA ADR**;
 - b. One external 500g accelerometer;
 - c. One high speed camera;
- and each driver must wear:
- d. In-ear accelerometers;
 - e. Biometric devices subject to Article C8.9.5.

F1 Teams must use their best endeavours to ensure that all those parts are in working order at all times.

C8.9.1 FIA ADR

The **FIA ADR** must be fitted and operated:

- a. In accordance with the instructions of the FIA.
- b. With its centre plane no more than 25mm from $Y=0$ and with its top facing upwards.
- c. With each of its 12 edges parallel to the coordinate system defined in Article C2.1.
- d. In a position within the **Cockpit** which is readily accessible at all times from within the **Cockpit** without the need to remove plank or floor.
- e. Positioned so that the entire unit lies:
either
 - i. Behind **RV-COCKPIT-DRIVER**, between $X_C = -475$ and $X_C = 100$ and below $Z=440$, with its connectors facing forward,or

- ii. Ahead of **RV-COCKPIT-DRIVER**, behind $X_c = -1075$ and below $Z=250$, with its connectors facing either forward or rearward.
- g. Via anti-vibration mountings giving a clearance of 5mm to all other objects.
- h. In order that the download connector is easily accessible when the driver is seated normally and without the need to remove bodywork.
- i. Within the operating limits specified by the supplier, in particular the maximum temperature limits.

The **FIA ADR** must be powered from a nominally 12V supply such that its internal battery can be recharged at all times when the car's electronic systems are powered and when the car systems are switched off, but a jump battery or umbilical is connected.

Details of the connections to the **FIA ADR** may be found in the document [FIA-F1-DOC-Cxxx](#).

C8.9.2 External accelerometer

The **FIA ADR** must be connected to one external 500g accelerometer which has been manufactured by a FIA designated supplier to a specification determined by the FIA.

The accelerometer must be fitted:

- a. In accordance with the instructions of the FIA.
- b. Within the **Cockpit**, solidly bolted to the **Survival Cell** using four 4mm bolts, with a body clearance of 5mm to all other objects.
- c. With each of its 12 edges parallel to and matching the coordinate system defined in Article C2.1.
- d. In order that the entire accelerometer body lies as close as possible to the plane $Y=0$ and within an axis-aligned cube with an internal diagonal bounded by points $[X_c, Y, Z]$ $[-500, -130, 0]$ and $[-250, 130, 150]$.
- e. In a position which is readily accessible at all times from within the **Cockpit** when the seat is removed.

Details of the accelerometer may be found in the document [FIA-F1-DOC-Cxxx](#).

C8.9.3 High speed camera

Each car must be fitted with a high speed camera which has been manufactured by the FIA designated supplier to a specification determined by the FIA.

The camera must be fitted in accordance with the instructions of the FIA, details of which may be found in the document [FIA-F1-DOC-Cxxx](#).

C8.9.4 In-ear accelerometers

Each driver must wear in-ear accelerometers which have been manufactured by the FIA designated supplier to a specification determined by the FIA.

C8.9.5 Biometric device

For the purpose of aiding driver rescue, the FIA may define biometric devices, to be worn by each driver and which have been manufactured by the FIA designated supplier to a specification determined by the FIA.

C8.10 Accident data

At any time following an accident or incident **F1 Teams** must make the **FIA ADR** available and accessible to the FIA. A representative of the **F1 Team** concerned may be present when data relevant to an accident or incident is being uploaded from the recorder. A copy of the data will be made available to the **F1 Team**.

Any conclusions as to the cause of an accident, or any data relevant to an accident, may only be published in the form of a report which has been agreed between the **F1 Team** concerned and the FIA.

C8.11 FIA Marshalling system

C8.11.1 All cars must be fitted with a marshalling system, comprising a car positioning system and a bidirectional race control to car communication system, which has been manufactured by the FIA designated supplier to a specification determined by the FIA.

No other parts which, in the opinion of the FIA are capable of performing a similar function, may be fitted to any car.

C8.11.2 Car Positioning Unit

The Car Positioning Unit must be positioned in the forward part of the **Survival Cell** respecting the requirements of **FIA-F1-DOC-Cxxx**.

- ~~i. With its upper surface at $Z=855$~~
- ~~ii. With the cover positioned symmetrically about $Y=0$~~
- ~~iii. With its forward face at $X_e=638$~~

C8.11.3 Details of the marshalling system may be found in the document **FIA-F1-DOC-Cxxx**.

C8.12 Track signal information display

All cars must be fitted with red, blue and yellow **Cockpit** lights, supplied as part of **the FIA Standard ECU**, the purpose of which are to give drivers information concerning track signals or conditions. The lights must be fitted directly in the driver's normal line of sight.

C8.13 Impact warning system

In order to give rescue crews an immediate indication of accident severity each car must be fitted with a warning light which is connected to the **FIA ADR**.

The light must face upwards and be recessed into the top of the **Survival Cell** and be positioned according to Drawing 10 of Appendix C3.

Details of the light and its control system may be found in the document **FIA-F1-DOC-Cxxx**.

C8.14 Installation of electrical systems or components

- C8.14.1** Exceptionally, each car may be equipped with a maximum of five test sensor installations, which do not comply with Article C3, during P1 and P2, provided:
- They could not materially affect the outcome any of the impact tests described in Article C13.
 - They lie entirely within an axis-aligned cuboid with an internal diagonal bounded by points $[X_F = -1350 -1300, -950 -925, -200]$ and $[X_{DH} = 1000, X_R = 1000, -950 900, 1100 1050]$.
 - No part of any sensor may lie above a triangular surface with vertices at $[X_C = -200, 0, 655]$, $[X_F = -1350 -1300, 1300 1225, 655]$ and $[X_F = -1350 -1300, 1300 -1225, 655]$.
 - They do not obstruct on-board camera views.
 - If attached to either the **RIS** or the **FIS**, they may only use fixings that were present at the homologation of the structure.

Any such test sensor installations do not need to be homologated.

The FIA technical delegate must be notified of any intended test sensor installations prior to the **Competition** at which they are first used.

- C8.14.2** **F1 Teams** must be notified of any changes to the installation instructions for any FIA specified systems or components before 1 March of the previous season.

- C8.14.3** Notwithstanding the provisions of Article C8.14.1, the use in testing of any system designed to adjust the ride height of the car in a way that is not compliant with Article C10 is prohibited.

C8.15 Timing transponders

All cars must be fitted with two timing transponders supplied by the officially appointed timekeepers. These transponders must be fitted in strict accordance with the instructions detailed in the document **FIA-F1-DOC-Cxxx**. **F1 Teams** must use their best endeavours to ensure that the transponders are in working order at all times.

C8.16 Cameras and camera housings

- C8.16.1** At all times throughout the **Competition**, cars must be equipped with six positions in which cameras or camera housings can be fitted. Referring to Drawing 2 of Appendix C3, all cars must carry:

- a camera in positions 4, and 5.
- a camera or camera housing in positions 1 and 2

If requested by the Commercial Rights Holder, a car must carry;

- a camera fitted in the driver's helmet and pointing forward,
- a camera in position 6.

- C8.16.2** Details concerning the technical specification of all cameras may be found in the document **FIA-F1-DOC-C022**.

C8.16.3 With the exception of the position in the driver's helmet, camera housings, when used, must be fitted in the same location as cameras, and satisfy all the relevant regulations. They must be identical in size, shape, and mass to the camera in lieu of which they are fitted, and must be supplied by the relevant **F1 Team**. Details concerning the shape and mass of all camera housings may be found in the document [FIA-F1-DOC-C022](#).

Any decision as to whether a camera or camera housing is fitted in those positions will be by agreement between the relevant **F1 Team** and the Commercial Rights Holder.

If a car is not required to carry either a camera in the helmet of the driver, or a camera in position 6, ballast of 0.35 kg must be securely fitted in the location of the Helmet Camera Processing Unit.

C8.16.4 **F1 Teams** must be notified of any changes to the camera or transponder installation instructions before 30 June of the previous season.

C8.16.5 Any camera fitted in positions 2, 3 or 4 shown in Drawing 2 of Appendix C3 must be mounted in order that its major axis does not subtend an angle greater than 1° to the plane Z=0, and its lateral axis is normal to the plane Y=0.

C8.16.6 **Position 1**

Any camera fitted in position 1 must be fitted above the **Survival Cell**, forward of the **Cockpit** opening, rearwards of the forward attachment of the **Secondary Roll Structure** ~~described in Article C12.4.2~~ and symmetrically with respect to the plane Y=0, with the camera pointing towards the driver. The electronic conditioning unit for this camera must be positioned within the **Survival Cell** and in accordance with the document [FIA-F1-DOC-C022](#).

C8.16.7 **Position 2**

On the left-hand side, a camera, or camera housing of the same mass must be fitted.

On the right-hand side, a lightweight camera housing, or a diagnostic camera defined in Article C3.18.15 (if required by the FIA) must be fitted symmetrically to the camera on the left-hand side.

The entire camera or housing in position 2 must lie within RV-CAMERA-2.

The camera fitted in position 2 shown in Drawing 2 of Appendix C3 must be mounted in order that its major axis where passing through the centre of the camera lens does not intersect any part of the car lying forward of the camera.

Any part provided by the **F1 Team** for the purpose of aligning the camera or housing in position 2 correctly will be considered part of the camera provided it does not exceed 25mm in width and is being fitted for that sole purpose.

C8.16.8 **Position 3**

The camera fitted in position 3 must be mounted in order that its forward-most point is situated between $X_c = 0$ and $X_c = 400$ 300 and between $Z = 890$ and $Z = 900$. The inner face of the camera should be between $Y = 120$ and $Y = 150$ 170.

Any part provided by the Competitor for the purpose of aligning the camera in position 3 must be an extrusion of the camera unit profile. A radius of up to 10mm will be permitted where this component meets the bodywork or survival cell.

C8.16.9 Position 4

The camera fitted in position 4 must be mounted in order that its forward-most point is forward of $X_c = 80$.

C8.16.10 Position 5

The camera fitted in position 5 must be mounted, symmetrically about $Y=0$, with the lens centre forward of $X_c = -1250$ and with its lower surface at an angle no greater than 6° to the plane $Z=0$. In order to not impinge on its 360deg image, any shrouding or cutout should be no higher than "Shoulder X", as defined in the document [FIA-F1-DOC-C022](#).

C8.16.11 Position 6

The camera fitted in position 6 must be mounted within the Rear Impact Structure with the face of the lens pointing rearwards at an angle no greater than 1° to the plane $X=0$.

C8.16.12 The CCU Antenna must be mounted; ~~with its lower surface at $Z=855$ and the centre of its connector on $Y=0$ and $X_c=-625$~~

- a. such that "Plane Y" (defined in [FIA-F1-DOC-C022](#)) is no more than 50mm in Z below the external surface of the Bodywork.
- b. Any part of the car above "Plane Y" and within ~~x~~mm of the periphery is not made of conductive material.
- c. symmetrically about the plane $Y=0$
- d. with the whole unit lying between planes either;
 - i. $X_c=240$ and $X_c=500$; or
 - ii. $X_c=-1050$ and $X_c=-1400$
- e. respecting the requirements of [FIA-F1-DOC-C022](#)

C8.17 Electromagnetic radiation

Electromagnetic radiation between 2.0 and 2.7GHz is forbidden save with the written consent of the FIA.

C8.18 Sensor signals

Any system, device or installation which is contrived or operated in a way to alter the measurement or the signal of a sensor used by the FIA to establish compliance with the Regulations is forbidden.

ARTICLE C9: TRANSMISSION SYSTEM

Advisory Committee: TAC

Governance: F1 Commission / WMSC

C9.1 Fundamental provisions**C9.1.1 Transmission type**

The transmission may only drive the two rear wheels.

C9.1.2 Traction control

No car may be equipped with a system or device which is capable of preventing the driven wheels from spinning under power or of compensating for excessive torque demand by the driver.

Any device or system which notifies the driver of the onset of wheel spin is not permitted.

C9.2 Clutch control

C9.2.1 **Clutch** operating devices must be in the form of paddles, which comply with the following principles:

- a. There should be a maximum of two, mounted on the steering wheel for direct access in all circumstances.
- b. They should be of pull-type, opening the **Clutch** when pulling the paddle towards the driver.
- c. Their travel should be in a plane nominally normal to the face of the steering wheel, with a maximum displacement of the driver's contact surfaces of 80mm between end stops.
- d. They should have only a single degree of freedom.
- e. Where two paddles are fitted, they must be a left and right handed pair, identical in function and ergonomics, mounted in a symmetrically opposite manner on either side of the steering wheel centre plane. For the avoidance of doubt, they must have the same mechanical travel characteristics and be mapped identically.

No interaction between them or the associated **FIA Standard ECU** inputs will be permitted and, furthermore, **F1 Teams** must be able to demonstrate beyond any doubt that each of the paddles may only be operated with only one hand.

- f. To ensure that the signals used by the **FIA Standard ECU** are representative of the driver's actions, each **F1 Team** is required to demonstrate that the paddle percentage calculated by the **FIA Standard ECU** does not deviated by more than $\pm 5\%$ from the physical position of the operating device measured as a percentage over its entire usable range.

In that context, the physical position of the paddle will be measured at the location operated by the fingers.

- g. **The paddle is the only device the driver may use to control the clutch demand. The position signal must not be altered by any other object including any insert within the driver's glove.**

C9.2.2 Designs which allow specific points along the travel range of the clutch operating device to be identified by the driver or assist the driver to hold a position are not permitted.

In order to prevent interaction between the clutch paddles and other driver control devices, at least one of the following arrangements must be respected:

- a. When pulled to its maximum travel position, any clutch paddle should not reach further than the driver's contact surfaces of any other paddle, lever or switch in any of their positions.
- b. The outboard 60% portion of any clutch paddle, measured from its mounting point to its outer edge by the driver's contact surface, should be a minimum of 50mm away over its entire travel range from any other paddle, lever or switch.
- c. A clutch paddle should be separated from any adjacent paddle, lever or switch by a physical stop preventing any practical interaction between them by the driver. Such stop should be sized and shaped so that it cannot be used as a reference point during paddle operation.

In addition, other parts of the steering wheel or chassis should not be practically usable as reference points for the driver to identify or hold a specific position.

C9.2.3 The minimum and maximum travel positions of the clutch operating device must correspond to the **Clutch** fully engaged normal rest position and fully disengaged (incapable of transmitting any useable torque) positions respectively.

C9.2.4 Designs or systems which are designed to, or have the effect of, adjusting or otherwise influencing the amount, or rate, of engagement being demanded by the **FIA Standard ECU**, are not permitted, with the exception of minimal inherent hydraulic and mechanical properties.

C9.2.5 The amount by which the **Clutch** is engaged must be controlled solely and directly by the driver with the exception of:

- a. Stall prevention.
- b. Gearshifts.
- c. Bite point finder where brake pressure, wheel speed and driver **clutch** demand safeguards are used.
- d. De-clutch protections.
- e. *Power train* protection on the track outside of any start lockout period or immediately following stall prevention activation only.
- f. Test signals enabled only when the car is connected to the garage system.

When commanded by the driver, the amount of clutch engagement will be expressed in the **FIA Standard ECU** as torque at the rear axle by applying a gain of 5200Nm / 90% to the clutch paddle position between 5% and 95%.

In that case the clutch torque controller implemented in the **FIA Standard ECU** must be used. Except for the first 70ms following the initial step in clutch torque demand during a launch, the control error, calculated using the **Power Unit** output shaft torque sensor, must be contained in a band of $\pm 150\text{Nm}$ when converted at the rear axle.

C9.2.6 When the clutch operating device is released from its maximum travel position it must return to its resting position within 50ms.

The maximum delay allowed, computed from the respective signals as recorded by the FIA ADR or **FIA Standard ECU**, between the clutch driver control input signal and the corresponding output demand being achieved is 50ms.

C9.2.7 Any device or system which notifies the driver of the amount of Clutch slip or engagement is not permitted.

C9.3 Clutch Disengagement System (CDS)

All cars must be fitted with a means of disengaging the **Clutch** for a minimum of fifteen minutes in the event of the car coming to rest with the engine stopped. This system must be in working order throughout the **Competition** even if the main hydraulic, pneumatic or electrical systems on the car have failed. This system must also shut down the ERS, as required by article C5.17.1.

In order that the driver or a marshal may activate the system in less than five seconds, the button which operates it must :

- a. Face upwards and be recessed into the top of the **Survival Cell** and be positioned according to Drawing 10 of Appendix C3.
- b. Be designed in order that a marshal is unable to accidentally re-engage the **Clutch**.
- c. Be marked according to Drawing 10 of Appendix C3.

C9.4 Homologated Gearbox and Component Classification

The design of the **Driveline Components** (with the exception of the gear ratios, for which the provisions of Article C9.6.2 apply), **Gear-Change Components** and **Auxiliary Components** must be homologated by each gearbox supplier before the start of the season following the season when they first supplied a **Gearbox** under these Regulations. The design must not be modified, except in exceptional circumstances, in subsequent seasons.

The **Gearbox Case** may be modified provided that the layout of the **Driveline Components**, Gear-Change components and **Auxiliary Components** is unchanged, except for a translation, as a group, in X.

A single upgrade to the **Gearbox** specification and layout will be permitted during this four-year period, such change only being permitted between two consecutive Championship Seasons. This then will be the only **Gearbox** design that can be used subsequently in the Championship by the **Supplying Team**. This upgrade must be made available to customer **F1 Teams**, who may opt to continue with the original specification and upgrade in a subsequent year.

Modifications may be made to the homologated **Gearbox** in the following cases:

- a. To resolve reliability problems.
- b. For cost saving, at the start of each season.
- c. In the case of materials, processes or proprietary parts becoming unavailable or having their use restricted for health and safety reasons.

In all cases; clear documentation justifying the change must be provided, prior approval must be obtained from the FIA, and the modification must not give any performance advantage. A summary of the modification will be circulated to all **F1 Teams** by the FIA.

The **Gearbox**, as defined in Appendix C1, is classified as **TRC**.

C9.5 Gearbox Dimensions

C9.5.1 Layout

The primary (lay) shaft must be concentric with the PU crankshaft centreline and must be driven at the same speed.

The secondary (main) shaft must lie within 30mm of $Y=0$, above the Primary Shaft and be parallel to it. The axes of the primary and secondary shafts must be between 90mm and 110mm apart.

The axis of any gear-change barrel must be above the axis of the secondary shaft.

The distance between the front lateral gear-tooth face of the forward-most forward gear ratio pair and the rear lateral gear-tooth face of the rearward-most forward gear ratio pair must be at least 175mm. The minimum distance must be respected by both the gears on the primary (lay) shaft and the gears on the secondary (main) shaft.

The axis of the final drive (at $X_{DIF}=0$) must be between $X_R=-60$ and $X_R=60$, between $Z=260$ and $Z=280$, and be between 390mm and 450mm behind the front lateral gear-tooth faces of both gears of the forward-most forward gear ratio pair.

The tip diameter of the final drive gear must be at least 205mm.

C9.5.2 Mass

The combined mass of driveline and gear-change components must be at least 22kg.

C9.6 Gear ratios

C9.6.1 The number of forward gear ratios must be 8. Continuously variable transmission systems are not permitted.

C9.6.2 Each **F1 Team** must nominate the forward gear ratios (calculated from engine crankshaft to drive shafts) to be employed within their **Gearbox**. These nominations must be declared to the FIA technical delegate at or before the first **Competition** of the Championship.

In the event the **F1 Team** obtains the **Gearbox** from another **F1 Team** as a **TRC**, the gear ratios used must be the same between those two **F1 Teams** unless the **Customer Team** opts to continue with the ratios used in the previous Championship Season.

During 2026 only, the nominated set of forward gear ratios may be changed once during the Championship Season.

Changes to the forward gear ratios under the provisions of this Article may involve changes to either the gear ratio pairs defined in Article C9.6.3, or to the final drive, but not both at the same time.

C9.6.3 No forward gear ratio pair may be:

- a. Less than 12mm wide when measured across the gear tooth at the root diameter or any point 1mm above or below the root diameter. Above this area each side of the gear teeth may be chamfered by a maximum of 10° . In addition, a chamfer or radius not exceeding 2.0mm may be applied to the sides and the tip of the teeth.

- b. Less than 600g in mass (excluding any integral shaft or collar). If an integral shaft or collar is to be excluded the mass of this may be shown by calculation assuming the gear to be 12mm wide and the shaft geometry to be the same as that where slide on gears are used.

C9.6.4 Gear ratio pairs must be made from steel.

C9.7 Reverse gear

All cars must be able to be driven in reverse by the driver at any time during the **Competition**.

C9.8 Gear changing

C9.8.1 Automatic gear changes are considered a driver aid and are therefore not permitted.

For the purposes of gear changing, the **Clutch** and **Power Unit** torque need not be under the control of the driver.

C9.8.2 Gear changing is restricted during the following periods:

One gear change is permitted after the **Race** or **Sprint Session** has started and before the car speed has reached 80km/h, provided every gear fitted to the car is capable of achieving at least 80km/h at 15 000rpm.

C9.8.3 The minimum possible gear the driver is able to select must remain fixed whilst the car is moving.

Each individual gear change must be separately initiated by the driver and, within the mechanical constraints of the **Gearbox**; the requested gear must be engaged immediately unless over-rev protection is used to reject the gear shift request. Once a gear change request has been accepted no further requests may be accepted until the first gear change has been completed.

Multiple gear changes may only be made under Article C5.16 or when a shift to **Gearbox** neutral is made following a request from the driver.

If an over-rev protection strategy is used this may only prevent engagement of the target gear, it must not induce a delay greater than 50ms. If a gear change is refused in this way, engagement may only follow a new and separate request made by the driver.

Any de-bounce time used to condition driver gear change requests must be fixed.

C9.8.4 The maximum permitted duration for down changes and up changes is 300ms and 200ms respectively. The maximum permitted delay for the latter is 80ms from the time of the driver request to the original gear being disengaged.

The duration of a gear change is defined as the time from the request being made to the point at which all gear change processes are terminated. If for any reason the gear change cannot be completed in that time the car must be left in neutral or the original gear.

C9.8.5 Distance channel or track position is not considered an acceptable input to gearbox control.

C9.9 Torque transfer systems

C9.9.1 Any system or device the effect of which is capable of transferring or diverting torque from a slower to a faster rotating wheel is not permitted.

C9.9.2 Any device which is capable of transferring torque between the principal axes of rotation of the two front wheels is prohibited.

C9.10 Driveshafts

Driveshafts must be made from steel. The bore, more than 150mm from the ends, must be of constant diameter. At one of the ends, the internal diameter of the final 150mm must be equal to or greater than the diameter of the bore of the constant diameter section.

Driveshafts must have the required features for the driveshaft torque sensor defined in Article C9.11

~~C9.11 Driveshaft Torque Sensors~~

~~Regulatory torque sensors must be fitted to measure the torque in each drive shaft.~~

~~The installation and the connectivity of each of these torque sensors to the **FIA Standard EGU** must be approved by the FIA.~~

C9.11. Structural Connection to Survival Cell

Any part which provides an additional load path, aside from the path through the studs defined under Art. C5.4.17, from the **Survival Cell** to the **Gearbox Case** is prohibited unless this is incidental to its principal purpose.

Furthermore, any such part must not provide a structural connection between this pair of assemblies beyond that which is reasonable for the safe and reliable fulfilment of its purposes.

ARTICLE C10: SUSPENSION, STEERING SYSTEMS, WHEELS AND TYRES

Advisory Committee: TAC

Governance: F1 Commission / WMSC

C10.1 Legality ride height

The attitude of the **Unsprung Mass**, in relation to the **Sprung Mass**, for the assessment of its compliance to the Regulations.

An **F1 Team** must define a unique legality ride height for the front axle and for the rear axle. These values:

- a. Must be physically attainable without changing or removing suspension components, with the exception of ride-height adjustment.
- b. Must be within ~~40mm~~ 15mm at the front and within 30mm at the rear of the ride height of the car when ~~presented for scrutineering~~ entering **Parc Ferme**.

C10.2 Sprung suspension

C10.2.1 Cars must be fitted with **Sprung Suspension**.

C10.2.2 The suspension system of each axle (front and rear) must be independent from the other axle and so arranged that its response results only from changes in load applied to the wheels of that axle.

C10.2.3 The suspension system comprises of:

- a. Outboard suspension: the suspension members connecting the uprights to the **Sprung Mass**, the upright and attachments, the wheel axles and bearings, wheel fasteners and the **Complete Wheels**.
- b. Inboard suspension: the mechanical arrangement of the components that provide the vertical suspension travel response of the suspension system to the changes in load applied to the wheels.

The inboard suspension is considered to be part of the **Sprung Mass**, whereas the outboard suspension is considered to be part of the **Unsprung Mass**.

C10.2.4 Any powered device which is capable of altering the configuration or affecting the performance of any part of any suspension system is forbidden.

C10.2.5 No adjustment may be made to any suspension system while the car is in motion.

C10.2.6 On each axle, the state of its suspension system must be uniquely defined by the angular position, and angular velocity of its two rockers. Inertial and hysteresis effects are acceptable provided they are incidental.

In addition, the following systems or configurations are not permitted:

- a. Any response of the suspension elements to body accelerations and/or angular acceleration of the rockers (e.g. any inerters, **Mass Dampers**, acceleration-sensitive valves in the dampers).
- b. Any coupling of the suspension systems to the braking or steering systems. Furthermore, any variation of ride height caused by the suspension geometry's kinematics must not exceed 2mm over the range of $\pm 12^\circ$, measured between the principal axis of rotation of the front wheel

and an X-plane. Compliance must be demonstrated using CAD with the vehicle at the legality ride height, using a rigid set-up wheel of spherical outer surface and diameter 700 mm with its centre point at $[X_w=0, Y_w=-168, Z_w=0]$.

For the avoidance of doubt, fixed suspension kinematic geometries which affect the reaction of contact patch forces such as “anti-dive”, “anti-squat”, “anti-lift” are permissible.

- c. Any form of ride height control or alteration via self-levelling systems or feedback loops.
- d. Any change of suspension characteristics resulting from track events acting as triggers with the exception of passive damping conforming to Article C10.4.3(b).
- e. Any storing of energy via any means for delayed deployment and/or any suspension system that would result in a non-incidentally asymmetry (e.g. hysteresis, time dependency, etc.) in the response to changes in load applied to the wheels.
- f. Coupling between suspension elements, such that the state of an element(s) is used to alter the response of another element(s).
- g. Any system such as spool valves, switches, ratchets, etc. intended to change the suspension elements' characteristics between different states. Valves within a suspension damper element are acceptable as long as the only function is to provide a passive change in the damper force response whilst conforming to Article C10.4.3(b).
- h. **Mass Dampers**, as defined in [Appendix C1 Article C10.1.5](#).

C10.3 Outboard suspension

C10.3.1 With the steering wheel rotation fixed, the position of each wheel centre and the orientation of its rotation axis must be completely and uniquely defined by a function of its principally vertical suspension travel, save only for the effects of reasonable compliance which does not intentionally provide further degrees of freedom.

Additionally, once the Wheel Coordinate System defined in Article C2.1.3 is applied, in side view, the [difference between the maximum and minimum](#) angle subtended between the Z_w axis and the Z axis [may must](#) not exceed 5 degrees [of variation](#) over the range of suspension vertical travel, with the steering wheel rotation fixed. Compliance must be demonstrated [by using CAD, using camber values of -3 degrees front and -1 degree rear](#).

C10.3.2 There must be six suspension members connecting each suspension upright to the **Sprung Mass**. Redundant suspension members are not permitted.

On the front axle, one suspension member per wheel must be connected to the steering system.

C10.3.3 Suspension members having shared attachment points will be considered by a virtual dissection into discrete members.

C10.3.4 The outboard attachment points of each suspension member (defined as the kinematic centre of rotation of the joint that allows relative rotation between a suspension member and its adjoining upright) must lie:

- a. outboard of $Y_w=0$.
- b. Above $Z_w=-100$ for the front axle and above $Z_w=-40$ for the rear axle

- c. Inside the Drum defined in Article ~~C3.13.2~~ C3.14.2.

Exceptionally, the outboard attachment point of a suspension member connected inboard, to the rockers defined in Article C10.4.1 and outboard, directly to another suspension member, may not satisfy the provisions of this Article, but must in any case:

- a. lie outboard of $Y_w=50$
- b. no more than 25mm from the load line of the suspension member it is attaching to
- c. together with the inboard attachment point of the same suspension member, lie on the same side of the suspension member it is attaching to when viewed from the front

C10.3.5 On the front axle only, considering the six suspension members connected to an upright, but excluding the members connected inboard to the steering system or the rockers defined in Article C10.4.1, they must form 2 independent pairs of members each with their inboard attachment points separated in X by no less than 300mm and above $Z=250$ mm. Furthermore to form a pair, each suspension member must also be accompanied by the suspension member with the closest outboard attachment point in Z_w .

C10.3.6 The structural part of each suspension member must:

- a. In any normal cross section relative to its load line (defined as a straight line between the inner and outer attachment point centres of the member) have two orthogonal axes of symmetry. Over the whole length of the member, the cross section must have a constant size, shape, and incidence to the plane $Z=0$ when assessed at the legality ride height.

Furthermore, the centroid may not be more than 5mm from the load line with the exception of front suspension elements locally for the sole purpose of ensuring minimum clearance with the **Wheel Rim** at full steering lock.

In the case of the suspension member connecting the front upright to the steering system this dimension may be up to 10mm.

Minimal exceptions will be permitted for the following:

- i. static ride height, camber, or toe adjustment components
 - ii. the passage of hydraulic brake lines, electrical looms, or wheel tethers.
 - iii. the attachment of flexures, rod ends or bearings.
 - iv. along the interface between members that are structurally connected to each other
 - v. Cut-outs to allow the passage of a suspension member connected at the inboard end to the rocker (Art C10.4.1)
 - vi. installation of strain gauge systems
- b. Not be in contact with the **External Air Stream**, unless it is of a circular cross section when measured normal to the load line.
 - c. Not vary the angle subtended by the major axis of the cross section in (a) and the plane $Z=0$ by more than ± 5 degrees from that at **Legality Ride Height** over the range of suspension vertical movement whilst Y_w remains parallel to the plane $X=0$ and by more than ± 1 degree from that at **Legality Ride Height** over the range of steering movement with the distance between the origin

of the wheel coordinate system and $Z=0$ held constant. Compliance must be demonstrated by CAD, using camber values of -3 degrees front and -1 degree rear.

d. One of the six rear suspension members per side may be exempt from part a) above.

C10.3.7 It must be possible to achieve a minimum angle of $+23^\circ/-21^\circ$ (positive angles mean toe in) between the principal axis of rotation of the front wheel and an X-plane. If necessary, the steering system may be disconnected from the suspension members or the steering arm may be changed to verify this requirement. The achievement of the minimum angles is intended at legality ride height and the bodywork defined in Articles ~~C3.13.3, C3.13.4 and C3.13.5~~ C3.14.3 through C3.14.9 may be removed.

C10.3.8 In order to help prevent a wheel becoming separated in the event of all suspension members connecting it to the car failing, flexible tethers as specified in Article C14.4.1 must be fitted. The sole purpose of the tethers is to prevent a wheel becoming separated from the car, they should perform no other function.

C10.3.9 Where any Suspension Member attaches to the **Survival Cell** behind $X_c=-1580$, **F1 Teams** should provide calculations showing that there would be no damage to the **Survival Cell** if a load of 1.25 times the compressive failure load of the leg is applied to the mounting, along the axis of the leg.

C10.4 Inboard suspension

C10.4.1 The inboard suspensions of the front and rear axles must only be actuated via a single rocker per wheel, with only a single outboard suspension connection to each rocker.

A rocker is a mechanical device that is rigidly supported on the **Sprung Mass** and rotates about a fixed axis on the **Sprung Mass** with no other relative degree of freedom.

C10.4.2 Suspension elements can only connect to the rockers or **Sprung Mass**, where any such connection is classified as a node, subject to the following restrictions :

- a. They only permit relative rotation at their nodes.
- b. They must be so arranged that any suspension element functions only in parallel to any other, even if multiple elements are physically combined into a single component and/or share physically coincident nodes.
- c. There is only one degree of freedom between the end nodes of each element. No functional connection may be used to any other part of the element in order to obtain, for example, a feedback signal for other parts of the suspension system.
- d. With the exception of sensors whose sole purpose is to provide data, no other device(s) may connect to a node or act on the rocker.

C10.4.3 The only permitted suspension elements are:

- a. Springs – the primary purpose of which is to absorb and release energy in a monotonically increasing load relationship with relative deflection between its nodes (or increasing torque with twist). Multiple springs may be combined in series or parallel to generate a single spring element entity between its nodes providing the result, as measured at the nodes, conforms to the monotonic requirement above and no part of the design has the purpose and/or effect of altering this relationship. Spring elements using a fluid medium are not permitted.

- b. Dampers – the primary purpose of which is to dissipate energy by generating an opposing force to the direction of motion as a function of the relative velocity between its nodes. Utilisation of heavily asymmetric damping forces for the purpose and/or effect of contravening Article C10.2.6 is not permitted. A gas spring as part of the functionality of a damper element, for the purposes of anti-cavitation, is acceptable as long as the spring rate, as measured between the nodes does not exceed 10N/mm.

Hysteresis is acceptable in an element providing it is at an incidental level and no attempt is made to utilise any inherent hysteresis to alter the response of the element relative to its primary purpose.

Links may be used to actuate the suspension elements that are mounted remotely from the rockers but cannot be used to circumvent or subvert the requirement of Article C10.2.6. Such links must be rigid and of minimal mass and design so as to achieve the linking mechanism. Links using a fluid medium are not permitted.

C10.5 Steering

- C10.5.1** The steering system is the mechanical system, on and part of the **Sprung Mass**, that converts the steering column demand into the outboard suspension position control for the re-alignment of only the two front *wheels* (the steered wheels).
- C10.5.2** The re-alignment of the steered wheels must be uniquely defined by a monotonic function of the rotation of a single steering wheel about a single axis. Furthermore, the inboard attachment points of the suspensions members connected to the steering system must remain a fixed distance from each other and can only translate in Y.
- C10.5.3** Power assisted steering systems may not be **Electronically Controlled** or electrically powered. No such system may carry out any function other than reduce the physical effort required to steer the car.
- C10.5.4** No part of the steering wheel or column, nor any part fitted to them, may be closer to the driver than a plane formed by the entire rear edge of the steering **Wheel Rim**. All parts fixed to the steering wheel must be fitted in such a way as to minimise the risk of injury in the event of a driver's head making contact with any part of the wheel assembly.
- C10.5.5** The steering wheel, steering column and steering rack assembly must pass an impact test, details of the test procedure may be found in Article C13.8.

C10.6 Suspension Uprights

- C10.6.1** The upright is the structural component, in the outboard suspension, which provides the physical mounting, kinematic restraint and load path connections of the wheel axle to the suspension member outboard attachments as well as the reaction of the brake calliper loads into the suspension.

There can only be one suspension upright per **Complete Wheel**.

- C10.6.2** The loads from the suspension members and wheel bearings must individually and entirely be carried by the suspension upright. Exceptionally up to three suspension members may be connected together by titanium, aluminium alloy or steel components before their load is passed into the upright. Any such components are in any case considered to be part of the upright assembly.

C10.6.3 No part of the upright assembly may be inboard of $Y_W=0$ except for parts solely for the attachment and fixing of a suspension member outboard attachment point, conforming to Article C10.3.4 (a) to (c), to the upright which may encroach no more inboard than a sphere of radius 25mm about the attachment point.

C10.7 Wheel rims

C10.7.1 Wheel rim material

With the exception of surface treatments for appearance and protection, **Wheel Rims** must be made from AZ70 or AZ80 magnesium alloy.

C10.7.2 Wheel rim dimensions

a. The **Wheel Rim** key dimensions are:

	Front Wheel	Rear Wheel
Rim Diameter	462.6 ± 0.1 462.5 / 463	462.6 ± 0.1 462.5 / 463
Tyre Mounting Width	315 ± 0.5	401.3 ± 0.5
Lip External Diameter	496 ± 0.5	496 ± 0.5
Overall Width	334 ± 0.5	420.3 ± 0.5
Outboard Lip Thickness	8.5 ± 0.2	8.5 ± 0.2
Inboard Lip Thickness	10.5 ± 0.2	10.5 ± 0.2

b. The **Wheel Rim** must be a solid of rotation formed by revolving a single profile around the axis of rotation of the **Wheel Rim**. The profile must be tangent continuous with a minimum radius of curvature of 8mm in the area:

i. more than 80mm from the axis Y_W

and

ii. outboard of $Y_W=-36$

and

iii. inboard of; $Y_W=-302$ for the front rim and $Y_W=-388$ for the rear rim

c. Once the revolved solid has been fully defined, material may be :

i. removed between $Y_W=-210$ and $Y_W=-392.5$ on the rear wheel and between $Y_W=-188$ and $Y_W=-319$ on the front wheel. Any new surface created must have no concave radius of curvature smaller than 6mm.

ii. removed in areas less than 80mm from the axis Y_W

iii. added or removed to form features for mounting the inflation valve and TPMS sensors

iv. removed on the outer flanges, between a radius of 238mm and a radius of 246mm from the axis Y_W and up to 1mm deep for wheel branding, logo, or part numbers.

v. added or removed to form features for mounting the disc described in Article C10.7.

- d. No part of the front or rear **Wheel Rim** may lie within **RV-F-RIM-MIN** or **RV-R-RIM-MIN** respectively.
- e. There must be no passage for air between the inboard and outboard cavities of the **Wheel Rim**. Any closing panel may either be integrated into the rim or may be a separate piece. **All separate closing panels must respect clauses (d), (j), and (k) of this Article. Closing panels which are not required to prevent airflow between the inner and outer cavities are not permitted.**
- f. The minimum **Wheel Rim** thickness is 2.5mm.
- g. The minimum bead thickness is 4.0mm (measured from hump to outer edge of the lip).
- h. The ETRTO standard bead profile is prescribed.
- i. The design of the wheel must meet the general requirements of the tyre supplier for the mounting and dismounting of tyres including allowance for sensors and valves.
- j. The **Wheel Rim** design cannot be handed between left and right designs.
- k. Features intended to influence the heat transfer characteristics of the **Wheel Rim** are not permitted. **F1 Teams** are required to submit designs to the FIA for approval.
- l. **Design guidelines for the Wheel Rims are set out in FIA-F1-DOC-C021. Any deviation from the guidelines must be agreed with the Tyre Supplier.**

C10.7.3 Wheel Rim Impact Test

All **Wheel Rims** must pass the impact test defined in Article C13.10.

C10.7.4 TPMS Sensor

All cars must be fitted with tyre pressure and temperature monitoring sensors which have been manufactured by an FIA designated supplier to a specification determined by the FIA.

The TPMS sensor must be mounted in accordance with the specification given in the document **FIA-F1-DOC-Cxxx**.

Wheel rims and tyre pressure and temperature sensors should be marked according to the corner colouring and labelling scheme defined in the document **FIA-F1-DOC-Cxxx**.

C10.7.5 Outboard Disc

A disc with an internal diameter of 310mm must be fitted to all wheels. Its outer face must be coincident with the outer plane of the revolution defined in Article C10.7.2.b.

No part of the disc or its fixings may lie within **RV-F-RIM-MIN** (front) or **RV-R-RIM-MIN** (rear).

With minimal exceptions for fasteners and access to the inflation valve, the disc must fully enclose **RS-F-RIM-DISC** on the front wheel and **RS-R-RIM-DISC** on the rear.

The outboard disc may only be made from materials listed in Articles C15.2.3 (Polymer Composites) or C15.2.4 (Polymers).

C10.7.6 Parts attached to the wheel rim

The only parts which may be physically attached to the wheel in addition to the tyre are listed below.

Item	Article	May enter RV-RIM-F/R-MIN	Additional Restrictions
Wheel Fastener	C10.9.1	Yes	
Disc and fixings	C10.7.5	No	
Drive Pegs	-	Yes	
Wheel Spacers	-	No	Must be equal thickness left and right on same axle.
Inflation Valve	-	Yes	
Closing Panels	C10.7.2.e	No	
Balance weights	-	Yes	Only as fitted by Tyre Supplier
Standard TPMS Sensor (Mandatory) and mounting	C10.7.4	Yes	
Standard Rim Temperature Sensor (Optional) and mounting	-	Yes	

C10.8 Tyres

C10.8.1 Tyre supply

- a. All tyres must be used as supplied by the manufacturer, any modification or treatment such as cutting, grooving, the application of solvents or softeners is prohibited. This applies to dry, intermediate and wet-weather tyres.
- b. If, in the opinion of the appointed tyre supplier and FIA technical delegate, the nominated tyre specification proves to be technically unsuitable, the stewards may authorise the use of additional tyres to a different specification.
- c. If, in the interests of maintaining current levels of circuit safety, the FIA deems it necessary to reduce tyre grip, it shall introduce such rules as the tyre supplier may advise or, in the absence of advice which achieves the FIA's objectives, specify the maximum permissible contact areas for front and rear tyres.

C10.8.2 Tyre specification

Tyre specifications will be determined by the tyre supplier, in agreement with the FIA, data will be divided into data blocks as defined in the document [FIA-F1-DOC-Cxxx](#) and according to the timetable given in that document.

Once determined in this way, the specification of the tyres will not be changed without the agreement of the Formula One Commission.

Notwithstanding the above, the FIA may decide to change the specification during the Championship season for safety reasons without notice or delay.

C10.8.3 Treatment of tyres

- a. Tyres may only be inflated with air or nitrogen.

- b. Any process the intent of which is to reduce the amount of moisture in the tyre and/or in its inflation gas is forbidden.
- c. A **Complete Wheel** must contain a single fixed internal gas volume. No valves, bleeds or permeable membranes are permitted other than to inflate or deflate the tyre whilst the car is stationary.
- d. The only permitted type of tyre heating devices are blankets that comply with the design prescriptions listed in Article C10.8.4.
- e. ~~With the exception of air entering through the apertures defined in C3.16.6 and C3.16.16, and the blankets permitted in (d) above.~~ Any ~~other~~ device, system or procedure (except for driving of the car) ~~the whose~~ purpose and/or effect ~~of which~~ is to heat, **cool**, or maintain the temperature of; the **Complete Wheels**, hubs, or brakes, ~~above the ambient air temperature, or to maintain their temperature if they are already warm;~~ is prohibited.

C10.8.4 Tyre heating systems design prescriptions

- a. Tyre heating systems may only use resistive heating elements and act upon the outer tyre surface.
- b. No more than three temperature controllable zones may be present on a single tyre blanket.
- c. A temperature controllable zone is at most composed of one heating element (the actuator) and one or more temperature sensor(s) solidly mounted on the blanket.
- d. The blanket temperature sensors may be used to control the delivered power of the actuator using a single-input single-output (SISO) feedback control strategy approved by the FIA. There should be no other sensors involved in the temperature control strategy.

If a temperature controllable zone contains more than one temperature sensor, the signals must be arbitrated by software prior to being used in the SISO feedback control loop. Additional software design guidelines may be found in the document [FIA-F1-DOC-Cxxx](#).

- e. At any time during a **Competition**, the heating system must provide mechanisms to:
 - i. Log and download an accurate record of the last 96 hours of operations. Information to be logged is defined in the document [FIA-F1-DOC-Cxxx](#) and will include power, and energy consumption.
 - ii. Accurately display in real-time the calibration, inputs and outputs of all control and arbitration strategies,
 - iii. Enable the FIA to test the operation of any tyre heating systems.
- f. All software, hardware and wiring must:
 - i. Be approved and homologated by the FIA prior to being used at a **Competition**,
 - ii. Provide a unique and unambiguous identification that enables the FIA to identify and compare the versions being used to the version presented in the homologation dossier at any time during a **Competition**.

Additional details may be found in the document [FIA-F1-DOC-Cxxx](#).

C10.9 Wheel attachment and retention

C10.9.1 The wheel must be attached to the car with a single fastener. The outer diameter of the fastener must not exceed 105mm and the axial length must not exceed 75mm. The wheel fastener may not attach or mount any part to the car except the wheel assembly described in Article C10.7.

C10.9.2 With the exception of manual torque wrenches, devices which are used to fit or remove wheel fasteners during the **Sprint Qualifying Session**, the **Qualifying Session**, **Sprint Session** or the **Race** may only be powered by compressed air or nitrogen or electricity.

Any sensor systems may only act passively.

C10.9.3 All cars, whilst under their own power, must be fitted with dual stage devices which will retain the wheel fastener in the event of it coming loose from both its full fitted position and from any angular position before the fastener begins to engage on the axle thread.

C10.9.4 Each **F1 Team** must provide test results which demonstrate that all dual stage devices must be able to :

- a. Withstand 20kN of axial tensile force exerted on the wheel nut in a direction away from the car centre line whilst the wheel nut is fully disengaged from the thread.
- b. Withstand 300Nm of torque exerted on the wheel nut in the unwinding direction whilst the wheel nut is partially engaged on the thread.

C10.9.5 Furthermore, the dual stage retaining systems must incorporate a means of allowing the wheel operator/fitter to visually identify an incorrectly fitted fastener.

~~**C10.9.6** No part of the axle, wheel nut, or wheel retention device may lie outboard of the outboard plane of the **Wheel Rim**.~~

C10.10 Dimensions**C10.10.1 Suspension Width**

The origin of the front Wheel Coordinate System may not lie outboard of Y=603 at Legality Ride Height.

The origin of the rear Wheel Coordinate System may not lie outboard of Y=525 at Legality Ride Height.

ARTICLE C11: BRAKE SYSTEM

Advisory Committee: TAC

Governance: F1 Commission / WMSC

C11.1 Brake circuits and pressure distribution

C11.1.1 With the exception of a **Power Unit**, all cars must be equipped with only one brake system. This system must consist of one pedal which operates two master cylinders. On the outlet side of the master cylinders the system must comprise of two hydraulic circuits, one circuit from one master cylinder to operate the two front wheels, the other circuit from the other master cylinder to operate the two rear wheels.

The rear braking system must be capable of providing at least 2500Nm of braking torque at each rear wheel without assistance from the **Power Unit** or MGUK. This torque must be achieved with a maximum calliper pressure of 150barG. **F1 Teams** are required to submit a test report demonstrating this requirement

The rear brake control system described in Article C11.6 will be regarded as part of circuit that operates the rear wheels. This system must be designed so that if a failure occurs in one circuit the pedal will still operate the brakes in the other.

The diameters of the master cylinders acting on the two rear wheels and the two front wheels must be within 3mm of each other and have the same available travel. The same principle must be applied in multi-stage master cylinder designs.

C11.1.2 The brake system must be designed so that within each circuit, the forces applied to the brake pads are the same magnitude and act as opposing pairs on a given brake disc. Any system or mechanism which can produce systematically or intentionally, asymmetric braking torques for a given axle is forbidden.

C11.1.3 Any powered device, other than the system referred to in Article C11.6, which is capable of altering the configuration or affecting the performance of any part of the brake system is forbidden.

C11.1.4 Any change to, or modulation of, the brake system, whilst the car is on the track must be made by the driver's direct physical input or by the system referred to in Article C11.6, and may not be pre-set.

C11.2 Brake callipers

C11.2.1 Brake callipers are defined as the parts of the braking system outside the **Survival Cell**, other than brake discs, brake pads, calliper pistons, components directly associated with the system referred to in Article C11.6, brake hoses and fittings, which are stressed when subjected to the braking pressure. Bolts or studs which are used for attachment are not considered to be part of the brake callipers.

C11.2.2 All brake callipers must be made from aluminium materials permitted in Article C15.2.1.b.

C11.2.3 No more than three attachments may be used to secure each brake calliper to the car.

C11.2.4 Each wheel must be equipped with one calliper. This calliper must have a minimum of one pair of opposing pistons and a maximum of four pairs of opposing pistons.

C11.2.5 The section of each calliper piston must be circular.

C11.3 Brake discs and pads

- C11.3.1** Each wheel must be equipped with one brake disc which must have the same rotational velocity as the wheel it is connected to.
- C11.3.2** All discs must have a maximum thickness of 34mm.
- C11.3.3** The diameters of the discs are between 325mm and 345mm for the front and between 260mm and 280mm for the rear.
- C11.3.4** The minimum diameter of cooling holes in the discs is 2.5mm.
- C11.3.5** Each wheel must be equipped with one or two opposing pairs of brake pads.

C11.4 Brake pressure modulation

- C11.4.1** No braking system may be designed to prevent wheels from locking when the driver applies pressure to the brake pedal.
- C11.4.2** No braking system may be designed to increase the pressure in the brake callipers above that achieved by the driver applied force to the pedal under all conditions except for the system referred to in C11.6.

C11.5 Liquid cooling

Liquid cooling of the brakes is forbidden.

C11.6 Rear brake control system

The pressure in the rear braking circuit may be provided by a powered control system provided that:

- a. The driver brake pedal is connected to a hydraulic master cylinder that generates a pressure source that can be applied to the rear braking circuit if the powered system is disabled.
- b. It does not exceed 1.2 times the pressure concurrently generated by the driver at the rear master cylinder.
- c. The powered system is controlled by the **Control Electronics** described in Article C8.2.

C11.7 Supply of Brake Friction and Brake System Hydraulic components

The Brake Disks and Pads described in Article C11.3, the Brake Calliper described in Article C11.2, the Master Cylinder described in Article C11.1 and Rear brake control system described in Article C11.6 are classified as OSC, in accordance with the provisions of Article ~~C17.6~~ C17.5.

ARTICLE C12: SURVIVAL CELL*Advisory Committee: TAC**Governance: F1 Commission / WMSC***C12.1 General Requirements****C12.1.2 Homologation**

The **Survival Cell** must be homologated in accordance with the provisions of Article C13.

C12.1.3 Demonstration by Calculation

Where the regulations require an **F1 Team** to demonstrate the strength of a component or structure by calculation, a reserve factor of 1.0 at ultimate failure should be used for metallic components and first-ply failure for composites.

The FIA may request **F1 Teams** to submit models and material properties used in these calculations for inspection.

C12.2 Survival cell specifications**C12.2.1 Cockpit Opening**

In order to ensure that the opening giving the driver access to the **Cockpit** is of adequate size; with the exception of the steering wheel, steering column, chassis mounted PCU8 display unit, seat and all padding required by Article C12.6.1 (including the forward most fixings), or the Windscreen defined in Article C3.11.1 and its fixings, no part of the **Survival Cell** or bodywork may lie within **RV-COCKPIT-ENTRY**.

With the secondary roll structure removed, **RV-COCKPIT-ENTRY** must be entirely visible from directly above.

The shape of the **Survival Cell** must be such that no part of this volume is visible when viewed from either side of the car.

The parts of the **Survival Cell** which are situated each side of the driver's head must be no more than 550mm apart.

C12.2.2 Survival Cell Dimensions

Before the openings and recesses allowed in Articles C12.2.1, C12.2.4 and C12.2.5 are created, a single volume, which is continuous, and has no apertures must be defined in accordance with the conditions laid out in (a)–(d), below. All parts of the **Survival Cell** in contact with the **External Air Stream** must comply with C3.2.3.

- a. No part of the **Survival Cell** may lie ahead of $X_A=0$.
- b. No part of the **Survival Cell** may lie behind $X_{PU}=0$.
- c. The minimum dimensions of the **Survival Cell** between $X_A=0$ and $X_C=0$ are defined by the union of **RV-CH-FRONT-MIN** and **RV-CH-MID-MIN**.
- d. The **Survival Cell** must fully enclose **RS-PU-ERS**.

- e. The maximum dimensions of the **Survival Cell** between $X_A=0$ and $X_C=-875$ are defined by the union of **RV-CH-FRONT** and the portion of **RV-FLOOR-BODY** that lies forward of $X_C=-875$ and inboard of $Y=\pm 210$.
- f. Material may be removed from the upper front part of the volume defined in (c) above. In order to do so, a Z-plane must be defined such that the remaining part of **RV-CH-FRONT-MIN** below it is at least 250mm high in every X-plane ahead of $X_C=-1600$. Material may only be removed above this Z-plane and ahead of $X_C=-1600$, in two stages:
 - i. After the first stage of material removal, the external surface of the **Survival Cell** forward of $X_C=-1590$, must enclose all mechanical components and associated brackets of the inboard front suspension at Legality Ride Height. Furthermore, any normal to this external surface must not subtend an angle greater than 25° to an X-plane, with the exception of the areas covered by the structural part of the front impact structure.
 - ii. In the second stage, further material may be removed down to the Z-plane defined above. In every X-plane, a cumulative total width of 100mm must remain from the surfaces created in the first stage of material removal. This may be either a single part 100mm wide, symmetrical about $Y=0$ or two parts, each 50mm wide, adjacent to each vertical side of the **Survival Cell**.

Structure that lies above the Z-plane and ahead of $X_C=-1600$ may be removable provided that the fastenings can resist a load of [50, 0, -30] kN, to be demonstrated by calculation.
- g. With the exception of any minimal apertures for front suspension members, and a recess for the timing transponder, the external surfaces of the **Survival Cell** and the external surfaces of the structural part of the front impact structure must coincide over the entire periphery of the **Survival Cell** at its front bulkhead.

C12.2.3 Identification Transponders

Every **Survival Cell** must incorporate three FIA supplied transponders for identification purposes. These transponders must be a permanent part of the **Survival Cell**, be positioned in accordance with Drawing 2 and must be accessible for verification at any time.

C12.2.4 Openings in the Survival Cell

The **Survival Cell** must have an opening for the driver, the dimensions of which are given in Article C12.2.1. Any other ducts, or openings in the **Survival Cell** must only:

- a. Be of the minimum size, and for the sole purpose of, allowing access to mechanical components.
- b. Be for the sole purpose of cooling the driver or mechanical or electrical components, the area of any such duct or opening may not exceed 3000mm^2 .
- c. Be for the sole purpose of routing wiring looms, cables or fluid lines, the total combined area of any such openings must not exceed 7000mm^2 .
- d. In the rear bulkhead for access to the ERS. The Fuel Bladder must not be exposed by this opening.

No openings may be made in the 100mm wide section(s) defined in Article C12.2.2.f.ii.

C12.2.5 Recesses in the Survival Cell Minimum Volume

Recesses are permitted in the **Survival Cell** minimum volume, defined in Article C12.2.2, for the following:

- a. For the sole purpose of, allowing the side impact structures and their mountings to be installed in accordance with Article C13.5.1. The area of each such recess for each side impact structure must not exceed 8 000mm² when projected onto a Y-plane.
- b. For the sole purpose of allowing the **Secondary Roll Structure** front fixing and fairings to be installed in accordance with Articles C12.4.2 and C3.12.3 (b). The total area of any such recess must not exceed 50 000mm².
- c. Minimal Recesses for the sole purpose of mounting mandatory components. Including but not limited to; timing transponder, F1MS Antenna, position 5 camera, medical light, datum-target seats, ERS Status Light, and CDS button.
- d. Minimal Recesses for the sole purpose of mounting team specified components. Including but not limited to; suspension brackets, **Suspension Fairings**, slip-angle sensor, bib stay mounting, and antennae.
- e. Recesses of maximum area 75 000mm² per side and of maximum depth 1.5mm, within the volume **RV-CH-FRONT-MIN**, for the sole purpose of mounting team specified Bodywork components.
- f. Recesses of maximum area 75 000mm² per side and of maximum depth 1.5mm, within the volume **RV-CH-MID-MIN**, for the sole purpose of mounting team specified Bodywork components.

Furthermore:

- g. The step surfaces of recesses no more than 3mm deep are not required to comply with the angle constraints of C12.2.2.f.i.
- h. Any recesses in areas covered by Article C12.3.1 – Anti Intrusion Laminate, must comply with that article's requirements for maintaining equivalent intrusion strength.

C12.2.6 Structure behind the driver

The parts of the **Survival Cell** immediately behind the driver which separate the **Cockpit** from the car's fuel tank, must lie outside **RV-COCKPIT-DRIVER**.

No head and neck support worn by the driver may be less than 25mm from any structural part of the car when the driver is seated in the normal driving position.

No part of any component that is required to be installed within **RV-PU-ERS**;

- a. that lies above Z=50, may lie ahead of **RS-FWD-FUEL-LIMIT**.
- b. that lies on or below Z=50, may lie more than 50mm ahead of **RS-FWD-FUEL-LIMIT**.

C12.2.7 Chassis Datum Points

For aligning the car for scrutineering, the **Survival Cell** should have the necessary precisely machined details to allow for the relevant legality datum points defined in Article **C3.3.3** ~~C3.2.6~~ to accurately positioned.

C12.3 Intrusion Protection**c12.3.1 Survival Cell Intrusion Specification**

In order to protect the driver and the fuel bladder in case of an impact, the sides and lower surfaces of the **Survival Cell** must comply with the following requirements:

- a. Surfaces which lie on or outside **RV-CH-FRONT-MIN**, or that are created by the recesses defined in Article C12.2.5.e, and lie;
 - i. Longitudinally, behind $X_c=-1630$ and ahead of **RS-INTSN-LAM-FWD**
 - ii. Vertically, above $Z=100$ and below the lower of; $Z=550$ and a curve 50mm below the top curve of **RV-CH-FRONT-MIN**

Must be constructed with ~~the~~ a single homologated laminate **HL-FWD-SC**

Any panel covering the Timing Transponder required by Article C8.15 is excluded from this requirement.

- b. Surfaces which lie;
 - i. Longitudinally, behind **RS-INTSN-LAM-FWD** and ahead of the intersection of **RS-FWD-FUEL-LIMIT** with the surface.
 - ii. Vertically, between $Z=100$ and $Z=550$
 - iii. Excluding recessed permitted by Article C12.2.5.a

Must be constructed with ~~the~~ a single homologated laminate **HL-COCKPIT-SIDE**.

- c. Surfaces which lie;
 - i. Longitudinally, ahead of $X_c=-415$.
 - ii. Vertically, below $Z=100$.
 - iii. Excluding recessed permitted by Article C12.2.5.a

Must be constructed with ~~the~~ a single homologated laminate **HL-COCKPIT FLOOR**.

- d. Surfaces that lie:
 - i. Longitudinally, behind the intersection of **RS-FWD-FUEL-LIMIT** with the surface and ahead of **RS-INTSN-LAM-RWD**.
 - ii. Vertically, between $Z=100$ and $Z=550$
 - iii. Excluding recessed permitted by Article C12.2.5.a

Must be constructed with ~~the~~ a single homologated laminate **HL-FC-SIDE**.

The following changes are permitted to the Homologated Laminates. The FIA Technical Delegate must be satisfied that the intrusion resistance of the structure has not been reduced by any modification and that its ability to pass the tests defined in Article C15.5.3 is maintained. Further guidance on what is and what is not permitted is given in the document **FIA-F1-DOC-Cxxx**.

- e. Where the Homologated Laminate is monolithic:
 - i. Plies may be added to the laminate

- ii. Solid Inserts may be incorporated into the laminate
 - iii. Core, reinforcing structures, and an additional skin may be added to the inside face of the laminate.
 - iv. Core or hollow reinforcing structures must not be added within the laminate.
- f. Where the Homologated Laminate is a sandwich construction:
- i. Plies may be added to the laminate of the inner or outer skin
 - ii. Solid Inserts may be incorporated within the laminate of the inner or outer skin
 - iii. Core density and thickness may be increased.
 - iv. Reinforcing structures and inserts may be added within or may replace the core locally. No replacement insert or structure may reduce the mass of the panel to which it is added.
 - v. Core or hollow reinforcing structures must not be added within either the inner or outer skin.

C12.3.4 Frontal Intrusion

It must be demonstrated by calculation that during a collision, the rear impact structure of a car ahead could not enter the **Survival Cell** through the front bulkhead if the Front Impact Structure were not present. For this calculation, a load of [215, 0, 0]kN should be applied through a pad of the same dimensions as the prescribed rear impact structure, anywhere on the front bulkhead of the **Survival Cell**. The pad should not intrude into the **Survival Cell** more than 50mm behind $X_A=0$. All components normally attached to the **Survival Cell**, except for the Front Impact Structure, must be considered in this evaluation.

C12.3.5 Cockpit Side Structure

The **Survival Cell** visible from the side that covers **RV-CH-MID-MIN** must be designed to resist the force of an impacting Front Impact Structure, at up to 380kN. This should be demonstrated by the tests and calculations defined in Article C13.4.7

C12.4 Roll Structures

All cars must have two roll structures that are designed to help prevent injury to the driver in the event of the car becoming inverted.

C12.4.1 Principal Roll Structure

The principal roll structure must satisfy the following geometric requirements:

- a. It must have structure at [$X_C=55, 0, 968$].
- b. A horizontal section through the structure at $Z=950$ must enclose an area of at least 6000mm^2 . The cross-sectional area may not be less than 6000mm^2 in any horizontal section below this plane.
- c. Above $Z=935$, the external surface of the structure must be tangent continuous, and must not contain any concave radius of curvature. Any convex radius of curvature must be no smaller than 20mm.

Compliance will be assessed without considering an opening in the structure to allow aerodynamic ducts to pass through. Any such opening must be below $Z=955$

Minimal local deviations from this surface are permitted at the intersection of the external surface and openings for an internal duct, and for the mounting of Camera 4.

- d. A horizontal section through the structure at $Z=910$ must enclose an area of at least 10000mm^2 . Furthermore, the section must enclose an axis-aligned square of side 70mm . These requirements must be maintained in any horizontal section below this plane.

When evaluating the above, only parts that genuinely contribute to the strength of the principal roll structure will be considered and no fairings may be included. Parts of the structure above $Z=935$ must be designed to support the car in a $20g$ vertical impact with the ground and be made from an abrasion resistant material.

The areas required in (b) and (d) above, will be taken as the area of the minimum convex polygon enclosing the structural parts of the roll hoop in that plane.

In order that a car may be lifted quickly in the event of it stopping on the circuit, the principal rollover structure must incorporate an unobstructed opening, whose section measures $60\text{mm} \times 30\text{mm}$ with internal radii of no more than $R15\text{mm}$, clearly visible in side view, to permit a strap to pass through it.

It must be shown by calculation that this opening is capable of resisting a load of 20kN applied by a strap in an upwards direction, on the ZX plane between $+45^\circ$ and -45° to the Z -axis. In designs where the strap could be threaded in different ways, calculations must be provided for all possibilities.

C12.4.2 Secondary Roll Structure (Halo)

The **Secondary Roll Structure**, which is not considered part of the **Survival Cell**, must be positioned symmetrically about the car centre plane with its front fixing axis at $X_c = -975$ and $Z=660$. The mounting faces for the rearward fixings must lie on the plane $Z=695$.

The **Secondary Roll Structure** must be made to standard FIA8869-2018 and supplied by an FIA designated manufacturer. Details of the structure and its mountings may be found in the document [FIA-F1-DOC-Cxxx](#).

The FIA will take the appropriate measures to ensure that **Secondary Roll Structures** supplied by different FIA designated manufacturers are of similar mass.

C12.5 Cockpit Specification

C12.5.1 Entry and Exit

The driver must be able to enter and get out of the **Cockpit** without it being necessary to open a door or remove any part of the car other than the steering wheel or the headrest as defined in Article C12.6.1.

From the normal seating position, with the safety harness fastened and whilst wearing the usual driving equipment, the driver must be able to remove the steering wheel and get out of the car within 7 seconds and then replace the steering wheel in a total of 12 seconds.

For this test, the position of the steered wheels will be determined by the FIA technical delegate and after the steering wheel has been replaced steering control must be maintained.

C12.5.2 Helmet Position

When seated normally, the driver must be facing forwards and the rearmost part of the crash helmet must be between $X_c = -50$ and $X_c = -125$.

The driver's helmet must lie below a line drawn between the front fixing axis of the **Secondary Roll Structure** and a point 75mm vertically below the highest point of the principal roll structure.

C12.5.3 Steering Wheel

The steering wheel, at any rotation, must lie below a line drawn between the front fixing axis of the **Secondary Roll Structure** and a point 75mm vertically below the highest point of the principal roll structure.

The steering wheel must be at least 50mm behind the front edge of the **Cockpit** opening.

The steering wheel must be fitted with a quick release mechanism operated by pulling a concentric flange installed on the steering column behind the wheel.

The steering wheel must be positioned so as it intersects **RV-COCKPIT-HELMET** at all angular positions.

C12.5.4 Internal cockpit volumes

- a. With the exception of the steering wheel, pedal assembly, driver's seat, and any padding that is required by Article C12.6.2, no part of the car may lie within a volume created by sweeping the outer vertical section shown in Drawing 3 of Appendix C3 between $X_c = -850$ and $X_c = -1415$.
- b. With the exception of the steering wheel, steering column, driver's seat, **additional padding complying with Article C12.6.2.e**, and pedal assembly, no part of the car may lie within a volume created by sweeping the inner vertical section shown in Drawing 3 of Appendix C3 between $X_c = -850$ and $X_c = -1515$.
- c. No part of the car may lie within the volume defined in **RV-COCKPIT-DRIVER** with the exception of:
 - i. Items required for driver comfort or restraint e.g., the seat and its mountings, safety harness and its mountings, drinks system, padding required by Article C12.6.1.
 - ii. Items required for the driver to control the car e.g. steering wheel, steering column, dash display, switch panels, associated looms, driver microphone & earpiece.
 - iii. Items that need to be accessed whilst the driver is seated in the car e.g. SDR download connector, connector for driver radio, associated looms, ES dousing connector.
 - iv. Driver ballast.
 - v. wiring looms or cables, excluding connectors, electrical boxes, or other electrical components.
 - vi. Fire extinguisher nozzles, tubes, and brackets.
 - vii. Fluid lines and their fittings

viii. The accelerometer close to the centre of gravity, required by Article C8.9.2.

- d. The driver, seated normally with the safety harness fastened and with the steering wheel removed must be able to raise both legs together so that the knees are past the plane of the steering wheel in the rearward direction. This action must not be prevented by any part of the car.

C12.5.5 Position of the Pedals

The face of the foremost pedal, when in the inoperative position, **must be no further forward than $X_A=315$. ~~situated at least 315mm behind the front bulkhead of the survival cell.~~**

It must be possible to mount the pedals with the face of the brake pedal as far forward as $X_C = -1515$. When mounted in the forward most position, the brake pedal, through the full pedal sweep, must maintain at least 10mm longitudinal clearance from any structure or component that could limit further movement.

C12.6 Cockpit Padding

C12.6.1 Headrest

All cars must be equipped with three areas of padding for the driver's head which:

- Are so arranged that they can be removed from the car as a single part.
- Are made from a material which is suitable for the relevant ambient air temperature, details of approved materials and the temperature bands in which they should be used may be found in the document **FIA-F1-DOC-Cxxx**.
- Are covered, in all areas where the driver's head is likely to make contact, with laminate **PL-HEADREST**.
- Are positioned to be the first point of contact for the driver's helmet in the event of an impact projecting the driver's head towards them during an accident.
- Must have a cover and internal structure which have no features that obstruct the padding's freedom to compress to 5% of its uncompressed thickness.
- Must be so installed that if movement of the driver's head, in any expected trajectory during an accident, were to compress the padding fully at any point, the driver's helmet would not make contact with any structural part of the car.
- Do not obscure sight of any part of the driver's helmet when he is seated normally and viewed from directly above the car.

Rear Padding

The first area of padding must be positioned behind the driver's head, be between 260mm and 380mm wide and be between 75mm and 90mm thick over an area of at least 40000mm². If necessary, and only for driver comfort, an additional piece of padding no greater than 10mm thick may be attached to this headrest provided it is made from the same material.

Side Padding

Two areas of padding must be positioned either side of the driver's head. These areas must:

- h. Be symmetrically positioned about $Y=0$.
- i. Be positioned with their upper surfaces at least as high as the **Survival Cell** over their entire length.
- j. Have a radius on their upper inboard edge no greater than 10mm.
- k. Be positioned in order that, forward of $X_c=-150$, the distance between the two is no less than 320mm.
- l. Be as high as practicable within the constraints of driver comfort.
- m. Extend as far forward as the forward face of **RV-COCKPIT-HELMET**.

Between $X_c = -75$ and $X_c = -400$ and above $Z=545$, the padding must be at least 95mm thick over an area greater than 35750mm^2 when viewed from the side of the car. This minimum thickness must be maintained to the upper edges of the **Survival Cell** and over their entire length. The minimum thickness will be assessed perpendicular to the plane $Y=0$ and prior to the application of the radius required by (j).

Furthermore, any void between these areas of padding and the rear part described above must also be completely filled with the same padding material.

If necessary, and only for driver comfort, an additional piece of padding no greater than 20mm thick may be attached to these headrests provided they are made from the same material which incorporates a low friction surface.

Fixings

The Headrest should be fixed in a way that is clearly indicated and should be easily removable without tools. Fixings should consist of:

- n. Two cylindrical longitudinal pegs with a diameter of at least 6mm and with an engagement of at least 12mm into the rear of the **Cockpit** opening
- o. A keyhole fixing at $X_c = -250 \pm 50\text{mm}$ and $Z=610 \pm 25\text{mm}$ on each side of the car. These fixings must comply with C12.6.1 (e) and the receptacle mounted on the **Survival Cell** must be flush with the **Survival Cell** structure. These fixings must prevent the headrest from moving laterally or vertically with up to 12mm of forward movement of the headrest. They may not be inside **RV-COCKPIT-HELMET** and should be designed to minimize the risk of injury should the driver come in contact with them during an accident.
- p. A quick release fixing which is clearly indicated at the front corner on each side of the car. No tape or similar material may be used to cover the forward fixings of the headrest.

C12.6.2 Leg Padding

In order to minimise the risk of leg injury during an accident, additional areas of padding must be fitted each side of, and above, the driver's legs.

These areas of padding must:

- a. Be made from a material described in the document [FIA-F1-DOC-Cxxx](#).
- b. Be no less than 25mm thick over their entire area.

- c. Cover the area situated between the plane $X_c = -875$ and 100mm behind the face of the rearmost pedal when in the inoperative position.
- d. Cover the area 50mm above the lower surface of the volume defined in Article C12.5.4.a, over its entire length, as defined in (c) above.
- e. An additional piece of padding may be placed between the driver's knees provided that:
 - i. It is securely attached to the satisfaction of the Technical Delegate
 - ii. It can be detached without tools
 - iii. It is present when compliance with Articles C12.5.1 and C12.5.4.d is assessed.

C12.7 Front Floor Structure

Below the **Survival Cell**, a structure, called **Front Floor Structure** must be fitted.

The **Front Floor Structure**:

- a. Must be securely mounted to the **Survival Cell**.
- b. Must only deform in the event of an impact with the ground.

A single device may be fitted between the **Front Floor Structure** and the **Survival Cell**. This device:

- c. Must not incorporate any component, mechanism or structure whose characteristics vary with time, velocity, acceleration or temperature. Including, but not limited to viscous damping, hysteretic damping and hydraulic systems.

The system as a whole:

- d. Must not incorporate any parts which may systematically or routinely exhibit permanent deformation.
- e. Must not be designed in such a way, or incorporate any component, mechanism or structure that can cause it to exhibit anything other than the same load deflection relationship measured during the test described in Article ~~C3.18.6~~ C3.18.5 whilst on the circuit (other than minor incidental effects such as those caused by inertia).
- f. Must be fully enclosed by the **Floor Bodywork** as specified in Article ~~C3.5.6~~ C3.5.12 such that no part of the structure is in contact with the **External Air Stream**.

C12.8 Seat fixing and removal

In order that an injured driver may be removed from the car in the seat following an accident, all cars must be fitted with a seat which, if it is secured, must be done so with no more than two fastenings. If fastenings are used, they must be:

- a. Clearly indicated and easily accessible to rescue crews.
- b. Fitted vertically.
- c. Removable without tools.

The seat must be equipped with receptacles which permit the fitting of belts to secure the driver and one which will permit the fitting of a head stabilisation device.

The seat must be removable without the need to cut or remove any part of the safety harness.

Details of the belt receptacles and the head stabilisation device may be found in the document FIA-F1-DOC-Cxxx.

C12.9 Driver Fit Information

Driver-fit information may be transferred between teams. Such information may include CAD geometries and measurements directly relating to driver-fit but must not include construction details.

Information that can be transferred includes: seat geometry, helmet position, steering wheel position, safety harness installation, elbow and knee clearance, pedal position, pedal-pad geometry, and heel-rest geometry.

In all cases, the content of the information to be transferred must be approved by the FIA before it is exchanged.

ARTICLE C13: SAFETY STRUCTURES AND HOMOLOGATION

Advisory Committee: TAC

Governance: F1 Commission / WMSC

C13.1 General Principles

- C13.1.1** The purpose of this Article is to define the safety structures of the car and all the homologation processes necessary to guarantee that each car that is eligible to race satisfies all the relevant requirements.
- C13.1.2** Should a fundamental weakness or sub-optimal level of safety become evident in either the definition of the structures or the homologation procedures, the FIA retains the right to modify the relevant regulations without observing the deadlines otherwise dictated by the prevailing governance regulations. In any case, such actions will be discussed in the Technical Advisory Committee.
- C13.1.3** All impact tests must be carried out in accordance with FIA Test Procedure 01/00, in the presence of an FIA technical delegate and by using measuring equipment which has been calibrated to the satisfaction of the FIA technical delegate. A copy of the test procedure may be found in the document [FIA-F1-DOC-Cxxx](#).
- C13.1.4** Any significant modification introduced into any of the structures tested shall require that part to pass a further test.
- C13.1.5** With the exception of tests described by Article C13.3.2, all static and dynamic load tests must be performed with the **Secondary Roll Structure** (whether dummy or otherwise) removed.

C13.2 Survival Cell Frontal Impact Test

A 50mm (± 1 mm) thick aluminium plate should be attached to the front bulkhead of the **Survival Cell** through the mounting points of the frontal impact absorbing structure. The plate should:

- Measure 430mm (± 1 mm) wide x 430mm (± 1 mm) high.
- Be fitted symmetrically about the plane $Y=0$.
- Be fitted in a vertical sense in order to ensure force distribution is similar to that with the nose fitted.
- Have seven M10 x 30mm holes in the outer face arranged in a grid pattern as shown in the diagram below. The test laboratory will then fit a 5mm thick 430mm x 430mm steel plate to these holes using a 5mm washer stack.

All parts which could materially affect the outcome of the test must be fitted to the test structure which must be solidly fixed to the trolley through its engine mounting points but not in such a way as to increase its impact resistance.

The fuel tank must be fitted and must be full of water.

A dummy weighing at least 75kg must be fitted with safety harness described in Article C14.5 fastened. However, with the safety harness unfastened, the dummy must be able to move forwards freely in the **Cockpit**. The dummy shall be equipped with a helmet to FIA8860 or FIA8859 and an FHR to FIA8858 (the mass of the helmet and FHR should be recorded, but should not be included in the 75kg). The safety harness shall be fastened to represent in-race conditions.

The fire extinguishers, as described in Article C14.1 must also be fitted.

For the purposes of this test, the total mass of the trolley and test structure shall be between 900kg and 925kg and the velocity of impact not less than 15 metres/second.

The impact wall must be fitted with seven carbon composite crush tubes which develop a combined 500kN nominal load as follows:

- 2 x tubes, 900mm long, from T-zero to T-end, directed into the lower left and right M10 attachment points.
- 1 x tube, 800mm long, from T-100mm to T-end, directed into the central M10 attachment point.
- 2 x tubes, 750mm long, from T-150mm to T-end, directed into the central upper and lower M10 attachment points
- 2 x tubes, 650mm long, from T-250mm to T-end, directed into the upper left and right M10 attachment points.

The specification of the tubes and details of how they should be mounted is given in the document [FIA-F1-DOC-Cxxx](#).

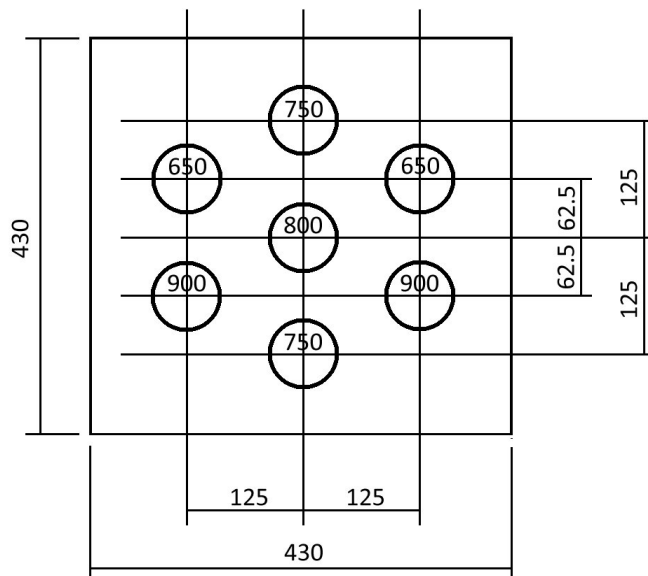

The resistance of the test structure must be such that following the impact there is no damage to the **Survival Cell** or to the mountings of the safety belts or fire extinguishers.

The maximum deceleration in the chest of the dummy for a cumulative 3ms shall be reported, this being the resultant of data from the three orthogonal axes.

This test may be carried out on any **Survival Cell** provided it has been successfully subjected to the tests described in Articles C13.3.1, C13.3.2 and C13.4. The test must however be carried out on the **Survival Cell** which was subjected to the test described in Article C13.4.8.

The peak **Survival Cell** acceleration from T=30ms must be at least 52g.

The maximum **Survival Cell** displacement from T=Zero is 425mm.

C13.3 Roll Structure Testing

C13.3.1 The principal roll structure must be subjected to one of the following static tests at 75% of the load (129kN), followed by one of the tests at full load (172kN). Both tests must be carried out on the same structure. The tests will be chosen at random and communicated to the **F1 Team** 3 weeks before their scheduled homologation date.

- a. A load of [99, 99, -98]kN
- b. A load of [-99, 99, -98]kN
- c. A load of [0, 0, -172]kN

For each test:

- i. Initially, the pad must not contact the roll structure below Z=935.
- ii. At any time during the test, the pad must not contact the structure below Z=900.
- iii. Rubber 3mm thick may be used between the load pads and the roll structure.
- iv. The peak load must be applied in less than three minutes and be maintained for 10 seconds.
- v. Under the load, deformation must be less than 25mm when measured along the loading axis and any structural failure limited to 100mm below the top of the roll structure when measured vertically.
- vi. During the test, the roll structure must be attached to the **Survival Cell** which is supported by a cradle which conforms to the Survival Cell below Z=100, fixed to it through its engine mounting points and wedged laterally by any of the static load test pads described in Article C13.4.2.
- vii. The load must be applied to the structure through a rigid pad with a recess up to 3mm deep, which conforms to the geometry of the Roll Structure. The Pad must be 200mm in diameter and perpendicular to the loading axis. The edge of the recess may be blended with a radius of up to 5mm.

Before performing the physical tests specified above, the **F1 Team** must submit detailed calculations to show that the principle roll structure and **Survival Cell** are able to sustain the 3 loads above and following loads:

- d. [141, 0, -98]kN
- e. [-141, 0, -98]kN
- f. [0, 141, -98]kN
- g. A load of 50kN applied normal to the surface through a 10mm diameter pad, anywhere on the external surface of the structure above Z=935.

C13.3.2 The **Secondary Roll Structure** attachments must be subjected to the following two static tests. For each test:

- a. Rubber 3mm thick may be used between the load pads and the roll structure.
- b. A **Secondary Roll Structure** as prescribed by C12.4.2 must be fitted.

- c. The loads shall be applied using a 150mm diameter flat, rigid pad whose centre lies in the specified loading position. The pad shall have only one translational degree of freedom, this being along the axis of load application.
- d. For each test, peak loads must be applied in less than three minutes and be maintained for five seconds.
- e. After five seconds of application, there must be no failure of any part of the **Survival Cell** or of any attachment between the structure and the **Survival Cell**.

Centreline Test

A load equivalent 130.1kN vertically downward and 51.6kN longitudinally rearward must be applied at a position [$X_c -785, 0, 830$]. in one of the following two ways:

- a. A physical test to 100% of the test load (140kN); or
- b. A physical test to 57% of the test load (80kN) plus detailed calculations to show that the attachments are able to sustain more than 120% of the test load (168kN) when fitted with the secondary structure as specified in Article C12.4.2 and with the deformation simulated as elastic.

The methodology for the calculations shall be authenticated with data from the physical test prescribed above for the load range from 0kN to 80kN. The load and displacement shall be recorded along the axis of load application together with the vertical displacement of the three attachments.

During the test, the structure must be attached to the **Survival Cell** which is supported on its underside on a flat plate, fixed to it through its engine mounting points and, optionally, through the front bulkhead and/or the mountings of the lower side impact structures.

Lateral Test

A load equivalent to 104.5kN laterally inward and 93.2kN longitudinally rearward must be applied to the outer surface of the structure at a position [$X_c -590, 233.5, 810$]. in one of following two ways:

- a. A physical test to 100% of the test load (140kN); or
- b. A physical test to 71% of the test load (100kN) plus detailed calculations to show that the attachments are able to sustain more than 120% of the test load (168kN) when fitted with the secondary structure as specified in Article C12.4.2 and with the deformation simulated as elastic.

The methodology for the calculations shall be authenticated with data from the physical test prescribed above for the load range from 0kN to 50kN. The load and displacement shall be recorded along the axis of load application together with the lateral displacement of the three attachments.

During the test, the **Survival Cell** should be fixed at its rear bulkhead via its engine mounts to a strongwall and supported along its lower face by a surface plate.

The **Survival Cell** may be restrained laterally and vertically at its front end by a cradle that wraps around all four sides of the **Survival Cell**. This cradle may extend as far forward as the plane $X_A=0$, but may not extend further rearwards than $X_A=600$.

The side of the **Survival Cell** that is opposite to the application point of the Halo test load may be restrained laterally by supports that conform to the sides of the **Survival Cell**. These lateral supports may not extend further forward than $X_c = -1075$ or above $Z = 545$.

A drawing of the method of support is given in the document [FIA-F1-DOC-Cxxx](#)

C13.3.3 In addition to the static load tests described above, each team must supply detailed calculations which clearly show that:

a. The **Survival Cell** will sustain

n a load of 75kN vertically upward on each rear attachment of the **Secondary Roll Structure**.

b. The **Survival Cell** and bracket will sustain a load equivalent to 99kN vertically upward and 99kN longitudinally rearward on the axis of the front attachment of the **Secondary Roll Structure**.

C13.4 Survival Cell Load Tests

C13.4.1 Conditions applicable to all static load tests

- a. The tests described in Articles C13.4.2 to C13.4.7 must be carried out on every **Survival Cell** intended for use. During these tests, the deflection across the inner surfaces must not exceed 120% of the deflection obtained on the **Survival Cell** used for the tests described in Articles C13.3.1 and C13.3.2. In cases where the original deflection was less than 3mm, the maximum permitted deflection will be the lower of; the permitted deflection, or 3.6mm.
- b. The tests described in Articles , C13.4.8, and C13.4.10 must be carried out on the **Survival Cell** used for the tests described in Articles C13.3.1 and C13.3.2.
- c. Deflections and deformations will be measured at the centre of area of the load pad unless otherwise stated.
- d. All peak loads must be applied in less than three minutes, through a ball jointed junction at the centre of area of the pad and maintained for 30 seconds.
- e. All tests must be carried out by using measuring equipment which has been calibrated to the satisfaction of the FIA technical delegate.
- f. A radius of 3mm is permissible on the edges of all load pads and rubber 3mm thick may be placed between them and the test structure.
- g. For the tests described in Articles C13.4, the **Survival Cells** must always be produced in an identical condition in order that their mass may be compared. If the mass differs by more than 5% from the one subjected to the impact test described in Article C13.2 further frontal and side impact tests and roll structure tests must be carried out.
- h. Any significant modification introduced into any of the structures tested shall require that part to pass a further test.
- i. The **Survival Cell** may be mounted in any orientation provided that the mounting arrangement does not increase the strength or stiffness of the **Survival Cell** being tested.
- j. For tests C13.4.2, C13.4.3, and C13.4.6 to C13.4.8, the **Survival Cell** must be supported by a cradle conforming to the shape of the side of **Survival Cell** opposite the load application.

C13.4.2 Survival cell fuel tank side test

A pad of diameter 225mm, which conforms to the shape of the **Survival Cell**, must be placed against the outermost side of the **Survival Cell** with the centre of the pad positioned at $[X_C, Z] = [100, 300]$.

A constant transverse horizontal load of 110kN will be applied and, under the load, there must be no structural failure of the inner or outer surfaces of the **Survival Cell**.

Deflections will be measured along the axis of load application.

Permanent deformation must be less than 3mm after the load has been released for 1 minute.

C13.4.3 Survival cell wheel contact side test

A pad 200mm in diameter which conforms to the shape of the **Survival Cell**, must be placed against the outermost side of the **Survival Cell**. The centre of this pad must lie at $X_C = -1195$ and in the Z-direction, at the mid-point of the height of the structure at that section.

Deflections will be measured across the inside of the **Survival Cell** along the axis of load application.

A constant transverse horizontal load of 100kN will be applied to the pad and, under the load, there must be no structural failure of the inner or outer surfaces of the **Survival Cell** and the total deflection must not exceed 15mm.

Permanent deformation must be less than 3mm after the load has been released for 1 minute.

C13.4.4 Survival cell floor test

A pad of 200mm diameter must be placed on the **Survival Cell** floor, in a position determined by the FIA technical delegate, and corresponding to the fuel tank. A vertical upwards load of 25kN will be applied.

Under the load, there must be no structural failure of the inner or outer surfaces of the **Survival Cell**.

Permanent deformation must be less than 1.0mm after the load has been released for 1 minute.

C13.4.5 Cockpit floor test

A pad of 200mm diameter must be placed beneath the **Survival Cell**, at $[X_C, Y] = [-600, 0]$, and a vertical upwards load of 75kN applied.

Under the load, there must be no structural failure of the inner or outer surfaces of the **Survival Cell**.

Deflections will be measured relative to the Cockpit rim along the axis of load application.

Permanent deformation must be less than 3mm after the load has been released for 1 minute.

C13.4.6 Cockpit rim tests

A pad of 50mm in diameter, must be placed on the side of the cockpit rim with its upper edge at the same height as the top of the cockpit side with its centre at $X_C = -250$.

A constant transverse horizontal load of 50kN will then be applied at 90° to the plane $Y=0$ and, under the load, deformation must be less than 10mm when measured along the loading axis and there must be no structural failure of the inner or outer surfaces of the **Survival Cell**.

Permanent deformation must be less than 1.0mm after the load has been released for 1 minute.

C13.4.7 Cockpit Side Test

A 225mm diameter pad which conforms to the shape of the **Survival Cell** at the load application point, must be placed against the outermost sides of the **Survival Cell**, centred at one of the positions $[X_c, Z]$;

- i. $[-720, 390]$
- ii. $[-540, 390]$
- iii. $[-360, 390]$
- iv. $[-540, 250]$

The position for the reference **Survival Cell** will be chosen at random and communicated to the **F1 Team** 3 weeks before their scheduled test date. Subsequent **Survival Cells** will be tested in the same position.

A load of 300kN shall be applied at no more than 15° to the Y-Axis through a ball joint and, under the load, there must be no structural failure of the inner or outer surfaces of the **Survival Cell** and the total deflection must not exceed 30mm. The load and displacement shall be recorded along the axis of load application.

After 5 seconds of application, there must be no failure of the **Survival Cell**.

The chassis support conditions shall be the same as those for the lateral test in Article C13.3.2., but the chassis may be mounted in any orientation, provided that the supports do not increase the strength of the **Survival Cell** in this load case, beyond the Article C13.3.2 arrangement.

A temporary spacer with a maximum diameter of 275mm and a maximum thickness of 6mm may be placed between the pad and the **Survival Cell**. The spacer must be composite with a quasi-isotropic laminate with Zylon, Dyneema, or Kevlar reinforcing.

In addition to the physical test, the team shall provide detailed calculations to show that the cockpit side is able to sustain a lateral load of 380kN applied at any of the four positions defined above.

The methodology for the calculations shall be authenticated by comparing data from the physical test for the load range from 0kN to 275kN and the calculated case.

C13.4.8 Nose Push-off Test

During this test, the **Survival Cell** must be resting on a flat plate and secured to it solidly but not in a way that could increase the strength of the attachments being tested.

A dummy front impact structure may be used for this test. The 250mm of the dummy structure closest to the **Survival Cell** should be identical in design and construction to the structure used in C13.6.2. The dummy structure should not in any way increase the strength of the **Survival Cell** or of the attachment between the **Survival Cell** and the impact structure.

A constant transversal horizontal load of 92kN must be applied to one side of the impact structure at $X_A = -600$ and at the mid-point of the height of the structure used in C13.6.2. All loads must be applied through a ball-jointed junction at the centre of area of the pad.

After 30 seconds of application, there must be no failure of the **Survival Cell** or of any attachment between the structure and the **Survival Cell**.

Additionally, teams must supply calculations that show that there would be no failure of the **Survival Cell** or of any attachment between the structure and the **Survival Cell** if a load of 110kN were applied $X_A = -600$ through the dummy structure.

C13.4.9 Engine Separation

It must be demonstrated by calculation that in the case of an accident that causes the engine to become separated from the **Survival Cell**, significant structural failure of the **Survival Cell** does not occur.

The **Survival Cell** should be restrained ahead of the seatback bulkhead. A load of $[F_x, F_y, M_z] = K \cdot [-1N, 5N, 3Nm]$, acting through and about $[X_{PU}=0, 0, 210]$, should be applied to the **Survival Cell** through the engine mounts using a representative engine. K should be increased up to the first engine mount failure. The analysis should be repeated, disconnecting the failed fixing until only two engine fixings remain. In all cases, the failure should remain local to the engine mounts and there should be no significant exposure of the fuel cell.

C13.4.10 Forward Survival Cell Test

A rigid pad measuring 100mm in X and only contacting the surface defined in 12.2.2.f.i, which has a single degree of freedom along the direction of loading, must be placed against the outer surface of the **Survival Cell**. The pad should conform to the shape the **Survival Cell**. The load axis must lie:

- On the plane $Y=0$
- In a position between the front of the **Survival Cell** and $X_C = -1600$, determined by the technical delegate and communicated to the team two weeks before the homologation.
- Normal to the surface of the **Survival Cell**.

A constant load of 30kN will be applied and, under the load, there must be no structural failure of the inner or outer surfaces of the **Survival Cell** and the deflection must be less than 5mm.

A cradle may be used on the opposite side of the **Survival Cell** to react the load.

C13.5 Side Impact Structure

C13.5.1 Side Impact Structure Specification

Two impact absorbing structures must be fitted on each side of the **Survival Cell** and must be solidly attached to it. The purpose of these structures is to protect the driver in the event of a lateral impact and, in order to ensure this is the case, strength tests of the mountings must be carried out successfully. Details of the test procedure may be found in Articles C13.5.3 and C13.5.4.

The impact absorbing structures must be manufactured and mounted to the **Survival Cell** in accordance with the following specifications:

- a. The construction and geometry of the structures may be found in the document **FIA-F1-DOC-Cxxx**.
- b. The structures must be mounted with the principal axes of their prismatic mounting sections perpendicular to the plane $Y=0$. The structures may be rotated $\pm 10^\circ$ about an axis normal to $Y=0$ which passes through the centre of area of their outermost longitudinal vertical cross section.

The centres of area of their outermost longitudinal vertical cross sections must be positioned:

- i. Longitudinally: between $X_c = -500$ and $X_c = -375$ for the upper structure and between $X_c = -525$ and $X_c = -425$ for the lower structure.
- ii. Vertically: between $Z=400$ and $Z=550$ for the upper structure and between $Z=75$ and $Z= 100$ for the lower structure.
- iii. Laterally: Within 15mm of each other.

Refer to the drawings which may be found in the document **FIA-F1-DOC-Cxxx**.

The side impact structures must be fully enclosed by bodywork, and hence no part of them should be exposed to the **External Air Stream**.

- c. Mountings must be permanently bonded to the structures to enable them to be attached to the **Survival Cell**, each of them must :
 - i. Incorporate a closed end and internal abutment to the impact structure that must be capable of withstanding the lateral load described in Article C13.5.4 without a structural contribution from the bonded interface.
 - ii. Lie entirely inboard of a plane which lies 292mm inboard of the outermost longitudinal vertical cross section of the impact structure.
 - iii. Be arranged in order that the outermost surface created by an interface between the mounting and structure lies on a vertical surface that is located between the plane defined in c.ii) and a vertical plane which intersects the leading and trailing edges of the structure no more than 357mm and 332mm inboard of the outermost longitudinal vertical cross section of the impact structure respectively.
 - iv. Be arranged in order that the innermost extent of the bonded interface between the mounting and structure is offset inboard by a minimum of 44mm from the vertical surface defined in (iii) above.
 - v. Be arranged in order that the bonded interface covers the entire external area of the structure between the innermost and outermost extents defined in iii) and iv) above.
- d. To allow for debris compaction, the internal volumes of the structures must be empty outboard of vertical planes which:
 - i. For the upper structure, intersects the leading, and trailing edges of the structure at least 342mm inboard of the outermost longitudinal vertical cross section of the impact structure. Furthermore, the projected area of the structure onto a Z-Plane, between this plane and the plane defined in c.ii) must be greater than 7440mm².

- ii. For the lower structure, intersects the leading, and trailing edges of the structure at least 357mm inboard of the outermost longitudinal vertical cross section of the impact structure. Furthermore, the projected area of the structure onto a Z-Plane, between this plane and the plane defined in c.ii) must be greater than 9225mm².

No parts which, in the opinion of the FIA technical delegate, would prevent proper function of the impact structures in the event of a lateral impact may be present in the volume lying between $X_c = -700$ and $X_c = -300$, and between $Z = 50$ and $Z = 600$, and outboard of a plane 280mm inboard of the outermost longitudinal vertical cross section of the inboard most impact structure.

The following components may be placed in this volume;

- i. Bodywork
- ii. Components of the oil and coolant systems and charge air cooling (excluding any **Secondary Heat Exchangers**)
- iii. Electrical systems (excluding electrical pumps and filters)
- iv. Pneumatic pressure vessels (excluding regulators operating at over 5 barG inlet pressure)
- v. Brake system, hydraulic system and pneumatic system hoses
- vi. A thermal store for the driver cooling system that has been homologated according to Article C14.6.9 and associated pipework.

Provided that;

- i. The construction of any of the components is such that they would not, in the opinion of the FIA technical delegate, cause significant damage to the **Survival Cell** in the event of a lateral impact,
- ii. Components of the oil and coolant systems and charge air cooling, electrical units and pneumatic pressure vessels are no closer than 20mm at any point to the closest impact structure,
- iii. Electrical units and pneumatic vessels;
have a total volume that does not exceed 2 litres on each side of the **Survival Cell**,
have an individual assembly density of no more than 1500 kg/m³,
are orientated such that corners or edges are not likely to cause significant damage to the **Survival Cell** in the event of a lateral impact.

C13.5.2 Side impact structure push-off calculations

Each team must supply detailed calculations which clearly show that the mountings of the upper and lower side impact structures are capable of withstanding:

- a. Horizontal loads of 40kN and 60kN applied simultaneously to the upper and lower structures respectively in a rearward direction through ball-jointed pads, which may conform to the shape of the structures, measuring 100mm high x 100mm wide and whose centre of area lies 100mm inboard of the centre of the outermost longitudinal vertical cross-section of the impact structure.

- b. Horizontal loads of 40kN and 60kN applied simultaneously to the upper and lower structures respectively in a forward direction through ball-jointed pads, which may conform to the shape of the structures, measuring 100mm high x 100mm wide and whose centre of area lies 100mm inboard of the centre of the outermost longitudinal vertical cross-section of the impact structure.
- c. A vertical load of 35kN applied in an upward direction to the lower impact structure through a ball-jointed pad, which may conform to the shape of the structure, measuring 200mm long x 100mm wide whose centre of area lies 100mm inboard of the centre of the outermost longitudinal vertical cross section of the impact structure.
- d. A vertical load of 27kN applied in a downward direction to the upper impact structure through a ball-jointed pad, which may conform to the shape of the structure, measuring 200mm long x 100mm wide whose centre of area lies 100mm inboard of the centre of the outermost longitudinal vertical cross section of the impact structure.

In all cases, the calculations should show that there will be no structural failure of the parts. It should be assumed that ball-jointed pads are used, the joint lying at the centre of area of the pad.

C13.5.3 Side impact structure push-off tests

These tests may be carried out on any **Survival Cell** provided it has been successfully subjected to the tests described in Articles C13.3 and C13.4. The tests may be performed on either side of the **Survival Cell**.

During the push off tests the **Survival Cell** must be resting on a flat plate and secured to it solidly but not in a way that could increase the strength of the attachments being tested.

Dummy test parts may be used in place of the impact structure provided the test part incorporates identical mounting details to those described in Article C13.5.1 and does not in any way increase the strength of the attachments being tested.

During the first test rearward horizontal loads of 40kN and 60kN must be applied simultaneously to the upper and lower structures respectively through ball joints or ball-jointed pads whose centre of area lies 100mm inboard of the centre of the outermost cross-section of the dummy impact structures.

During the second test an upward vertical load of 35kN must then be applied to the lower impact absorbing structure using a ball joint or a ball-jointed pad whose centre of area lies 100mm inboard of the centre of the outermost cross section of the dummy lower impact structure.

After five seconds of application there must be no failure of any structures or of any attachment between the structure and the **Survival Cell**.

C13.5.4 Side impact structure squeeze tests

This test may be carried out on any **Survival Cell** which has been subjected to the tests described in Articles C13.3 and C13.4. The test may be performed on either side of the **Survival Cell**.

During the test, the **Survival Cell** may be supported in any way provided this does not increase the strength of the attachments being tested.

Dummy test parts may be used in place of the impact structure provided the test parts incorporate identical mounting details to those described in Article C13.5.1 and do not in any way increase the strength of the attachments being tested.

Loads of 100kN and 150kN must be applied simultaneously to the dummy upper and lower structures respectively in a lateral direction using a hemispherical pad or ball joint, loading through the centre cross section, 292mm from the outermost longitudinal vertical cross-section of both impact structures.

After five seconds of application, there must be no failure of the **Survival Cell** or the attachments between the structures and the **Survival Cell**.

Each team must supply detailed calculations which clearly show that the mountings of the upper and lower side impact structures satisfy the requirement of C13.5.1.(c).(i).

C13.6 Front Impact Structure

C13.6.1 Front Impact Structure Specification

An impact absorbing structure (**FIS**) must be fitted in front of the **Survival Cell**. This structure must not be an integral part of the **Survival Cell** but must be solidly attached to it and be arranged symmetrically about the plane $Y=0$.

The **FIS** must affix to the **Survival Cell** using a minimum of four attachments having the same nominal strength.

Excluding fairings or any bodywork defined as **Front Wing Assembly**; Between $X_{FIS} = 50$ and $X_A = -100$, the intersection of the **FIS** with an X-plane must create a single cross section where:

- The height, width and enclosed area must increase monotonically with increasing X distance.
- At $X_{FIS}=50$, the enclosed area must exceed $9\,000\text{mm}^2$ and must enclose a rectangle 120mm wide by 65mm high.
- At $X_{FIS}=150$, the enclosed area must exceed $20\,000\text{mm}^2$.
- Between $X_A=-400$ and $X_A=-100$, the enclosed area must exceed a value given by a linear taper between $45\,000\text{mm}^2$ and $60\,000\text{mm}^2$ respectively.
- Ahead of $X_{FIS}=50$, no part may lie above $Z=235$
- Behind $X_{FIS}=50$, no part may lie above a plane that is normal to $Y=0$ and contains points $[X_{FIS}, Z]$; $[50, 235]$ and $[150, 305]$.
- Behind $X_{FIS}=250$, with the exception of bodywork joggles, any normal to the external surface of the Impact structure must not subtend an angle greater than 25° to an X-plane.
- All lines drawn normally and externally to a cross-section taken at $X_A = -100$ must not cross the plane $Y=0$

Once the requirements of (a) to (h) have been met, minimal apertures may be applied for mechanical components or sensors.

Any bodywork ahead of the plane defined in (f), above $Z=235$, and less than 166mm from the centre plane must be constructed of laminate with an areal weight of reinforcing, no greater than 800gm^{-2} with optional aramid or foam core.

C13.6.2 Front Impact Structure Homologation

Two identical **FIS**s must be presented for homologation. By random allocation by the FIA delegate:

- i. One will be subject to push-off tests described in Articles C13.6.3.a and C13.6.3.b followed by the dynamic test described in Article C13.6.5.

and

- ii. The second will be subject to push-off test described in Articles C13.6.3.c followed by the dynamic test described in Article C13.6.6.

In the case where a dynamic test did not meet the acceleration requirements, at the discretion of the FIA, the **F1 Team** may be permitted to repeat only the failed test.

C13.6.3 Front Impact Structure Push-Off Tests

During these tests, the **FIS** must be mounted to the same fixture that is used for the tests described in Article C13.6.5 and C13.6.6.

a. Lateral Push-off Test

A constant transversal horizontal load of 92kN must then be applied to one side of the **FIS** at $X_A = -600$ and at the mid-height of the **FIS** at this plane.

The load must be applied through a ball-joint, using a pad measuring 200mm in X, positioned symmetrically about $X_A = -600$. The stiffness of the pad may be chosen by the team. Rubber or foam may be used between the pad and the test structure.

The centre of area of the pad must pass through the plane mentioned above and the mid-point of the height of the structure at the relevant section. After 30 seconds of application, there must be no failure of the structure or of any attachment between the structure and the fixture.

b. Wing Section Push-off Test

Two equal loads, each equivalent to 3.2kN vertically downward and 2.2kN longitudinally rearward, must be applied simultaneously to the wing section at $Y = \pm 250$ mm. The load vector should intersect the top surface of the wing section between 75mm and 200mm behind the leading edge of the forward wing element, measured in the X-direction.

The loads shall be applied through a ball joint, using rectangular pads measuring no more than 100mm in Y and no more than 200 mm in X and with the lower surface shaped to match the wing section. 3mm rubber or foam may be used between the pad and the test structure. The pads must lie entirely between 200mm and 300mm from the plane $Y = 0$.

After 30 seconds of application, there must be no failure of the impact structure or of any attachment between the impact structure and the wing section.

c. Lateral Push-off Test to Failure

A transversal horizontal load must then be applied to one side of the **FIS** at $X_A = -900$ and at the mid-height of the Front Impact Structure at this plane.

The load must be applied through a ball-joint, using a pad measuring 200mm in X, positioned symmetrically about $X_A = -900$. The stiffness of the pad may be chosen by the team. Rubber or foam may be used between the pad and the test structure.

The load must be increased to failure, defined as the point where the load supported by the structure has fallen to 75% of the maximum load reached and an area of failure is apparent.

Failure should occur at a load greater than 52.5kN and the failure must be behind $X_A=-650$.

C13.6.4 Front Impact Structure Dynamic Tests – General Requirements

To simulate in-car conditions, all parts that could materially affect the outcome of the test must be fitted to the test structure. The test structure must be solidly fixed to the impact wall, through the mounting points of the FIS, but not in such a way as to increase its impact resistance.

If the test facility includes a system to manage excess residual energy (in the event that the **FIS** fails to absorb all the test energy), such a system must not in any way modify the results during a successful test.

The total mass of the trolley and test structure shall be 900kg (+1%/-0).

The resistance of the test structure must be such that during the impact:

- a. The deceleration profile measured in g from the first deformation of the complete assembly to $X_A=-382$ does not exceed the limit curve defined by $13.5/X^{1.13}$, where X is the longitudinal distance from $X_A=0$, calculated by the test laboratory in metres.
- b. The peak deceleration does not exceed 40g.
- c. Exceptionally, when filtered with a CFC60 filter (ISO 6487), the limit curve may be exceeded by up to 10g with an absolute ceiling of 43g, for a maximum cumulative period of 15ms.

Furthermore, there must be no damage to the mountings of the **FIS** to the test fixture.

C13.6.5 Front Impact Structure Dynamic Test 1

This test may only be carried out on the **FIS** which was subjected to the tests described in Article C13.6.3 (a) & (b).

As well as the general requirements defined in Article C13.6.4;

- a. The impact velocity must exceed 17ms^{-1}
- b. The average deceleration over the first 150mm of deformation of the **FIS** must exceed 2.5g.
- c. After the impact, the remaining length of the **FIS** must be greater than 150mm. This will be measured between the furthest point that the trolley reaches and the most forward of:
 - i. Any significant change in the construction of the **FIS** such as inserts, or openings.
 - or
 - ii. Any mechanical components mounted to the **Survival Cell** ahead of the front bulkhead except for components listed in (d) below.
- d. Subject to approval by the FIA Technical Delegate, the following components may be placed in the 150mm remaining length:
 - i. Brake reservoirs, their mounting brackets, associated pipes and fittings.
 - ii. Electrical systems with an individual assembly density of no more than 1500kg/m^3
 - iii. Composite internal bodywork panels with a wall thickness less than 1.5mm.

- iv. Parts of the X-mode adjustment system.
- v. A thermal store for the driver cooling system that has been homologated according to Article C14.6.9 and associated pipework.

C13.6.6 Front Impact Structure Dynamic Test 2

This test may only be carried out on the **FIS** which was subjected to the test described in Article C13.6.3 (c). An **F1 Team** may trim material from the **FIS** before this test.

As well as the general requirements defined in Article C13.6.4, the impact velocity must exceed 14ms^{-1} .

C13.7 Rear Impact Structure

C13.7.1 Rear Impact Structure Definition

An impact absorbing structure must be fitted behind the **Gearbox** in accordance with the following specifications:

- a. Between $X_{\text{DIF}}=325$ and $X_{\text{DIF}}=750$, the external geometry of the Rear Impact Structure must conform to **RV-TAIL-RIS** with a manufacturing tolerance of $\pm 0.5\text{mm}$.
- b. The rearmost face of the structure must be positioned at $X_{\text{DIF}}=750$. The upper surface of the structure on $Y=0$ must lie at $Z=372.5$. A tolerance of $\pm 2\text{mm}$ will be accepted for manufacturing reasons only.
- c. To minimise the likelihood of the structure penetrating a **Survival Cell**, it must be designed so that the majority of its material lies evenly around its perimeter. The perimeter of any X-plane between points 50mm forward of its rear face and 200mm forward of its rear face must be of a uniform construction and have a minimum thickness of 1.6mm. Material with a specific gravity of less than 1 will not be considered when calculating these thicknesses and, furthermore, any internal structure must not be thicker than any part of the perimeter at that section.

Only those parts of the structure which genuinely contribute to its performance during the impact test, and which are designed and fitted for that sole purpose, will be considered when assessing compliance with any of the above.

- d. No parts which, in the opinion of the FIA technical delegate, would prevent proper function of the impact structure in the event of a rear impact may be present behind $X_{\text{DIF}}=325$.

The Rear Impact structure is classed as TRC.

C13.7.2 Rear impact Structure Static Load Tests

To verify the strength of the **Gearbox** and the attachment of the rear impact structure to the **Gearbox**, the **Gearbox** and impact structure must pass three static load tests.

During the tests, the **Gearbox** should be solidly fixed by the engine studs and the test load may be reacted ahead of any joint between the impact structure and the **Gearbox Case**. No support may increase the strength of this joint.

The **Gearbox** and crash structure will be subjected to the following separate tests:

- a. A lateral load of 40kN applied at the mid-height of the structure at $X_{\text{DIF}}=500$ applied using a pad measuring 100mm in X and at least 150mm in Z.

- b. A load of 40kN vertically upwards applied on the plane $Y=0$ at $X_{DIF}=500$ applied using a pad measuring 100mm in X and at least 100mm in Y.
- c. A load of 40kN vertically downwards applied on the plane $Y=0$ at $X_{DIF}=500$ applied using a pad measuring 100mm in X and at least 100mm in Y.

These pads should conform to the shape of the rear impact structure and their centres of area must pass through the plane mentioned above and the mid-point of the height/width of the structure at the relevant section.

A radius of 3mm is permissible on the edges of all load pads and rubber 3mm thick may be placed between them and the test structure.

In each case, the load should be applied through a ball-joint and after 30 seconds of application, there must be no failure of the impact structure, of the **Gearbox**, or of the attachment between the impact structure and the **Gearbox**.

C13.7.3 Rear impact Structure Dynamic Test

All parts which will be fitted behind the rear face of the engine and which could materially affect the outcome of the test must be fitted to the test structure. If suspension members are to be mounted on the structure they must be fitted for the test. The structure and the **Gearbox** must be solidly fixed to the ground and a solid object, having a mass of 875kg (+1%/-0) and travelling at a velocity of not less than 11 metres/second, will be projected into it.

The object used for this test must be flat, measure 450mm (± 3 mm) wide by 550mm (± 3 mm) high and may have a 10mm radius on all edges. Its lower edge must be at $Z=0$ (± 3 mm) and must be so arranged to strike the structure vertically and parallel to $X_c=0$.

During the test, the striking object may not pivot in any axis and the crash structure may be supported in any way provided this does not increase the impact resistance of the parts being tested.

The resistance of the test structure must be such that during the impact:

- a. The deceleration profile measured in g does not exceed the limit curve defined by $15 + 26.5 X$, where X = the longitudinal distance from the start of the impact, calculated by the test laboratory in metres.
- b. The maximum deceleration does not exceed 25g.
- c. For $X > 0.225$ m, the maximum deceleration may exceed the limits defined in (a) and (b) for up to a cumulative 15ms.

Furthermore, all structural damage must be contained within the area behind $X_R=0$.

This test must be carried out on the rear impact absorbing structure which was subjected to the test described in Article C13.7.2.

C13.8 Steering Column Impact Test

The parts referred to in Article C10.5.5 must be fitted to a representative test structure; any other parts which could materially affect the outcome of the test must also be fitted. The test structure must be solidly fixed to the ground and a solid object, having a mass of 8kg (+1%/-0) and travelling at a velocity of not less than 7metres/second, will be projected into it.

The object used for this test must be hemispherical with a diameter of 165mm (± 1 mm).

For the test, the centre of the hemisphere must strike the structure at the centre of the steering wheel along the same axis as the main part of the steering column.

During the test the striking object may not pivot in any axis and the test structure may be supported in any way provided this does not increase the impact resistance of the parts being tested.

The resistance of the test structure must be such that during the impact the peak deceleration of the object does not exceed 80g for more than a cumulative 3ms, this being measured only in the direction of impact.

After the test, all substantial deformation must be within the steering column and the steering wheel quick release mechanism must still function normally.

C13.9 Headrest Load Test

The headrest must pass a load test. The load applied will be $P = (700 \times m_{HR})N$, where m_{HR} is the mass of the complete headrest in kg fitted with 'pink' Confor foam. The load may be applied either:

- a. With the headrest mounted in a dummy cockpit surround, a force of $[-P/2, 0, 0]$ will be applied simultaneously to each of two positions on the back of the headrest, at $Z=630$ mm and $Y=\pm 130$ mm.

or

- b. With the headrest mounted in the car, a force of $[-P, 0, 0]$ will be applied, evenly shared between two pull rods, to the back of the headrest, at $Z=630$ mm and $Y=\pm 130$ mm. The pull rods should pass through holes in the headrest of no greater than 2.5mm diameter. The force should be reacted against the **Secondary Roll Structure** forward mount.

At the test load, the pegs at the rear of the headrest must remain engaged in the holes in the chassis or dummy chassis, and there must be no failure of the headrest backing structure or the quick release mountings.

Load spreader plates may be used to apply the load to the back of the headrest provided that each load spreader is more than 80mm and less than 180mm from the car centre-plane.

C13.10 Wheel Rim Impact Test

All **Wheel Rim** designs must pass an impact test, derived from the standard ISO 7141:2022, to the outer flange.

The wheel must be mounted on a compliant fixture with the outer flange uppermost and at 13° to horizontal. The Wheel nut must be tightened to a torque of 500 Nm.

The rim must be fitted with a tyre, inflated to 150 ± 10 kPa.

A mass of 75 kg must be dropped onto the highest point of the rim from a height of 2000mm. The striker must have a rectangular section and overlap the rim by 25 ± 1 mm.

The wheel is considered to have failed the test if any of the following apply:

- a) visible fracture(s) (not by dye penetrant) penetrating through the barrel, spokes, or hub of the rim and more than 25mm away from the area of the rim section struck by the face plate of the striker.

b) the tyre loses more than 100kPa of air pressure within 1 min.

Details of the equipment, calibration and test procedure are given in standard ISO 7141:2022.

ARTICLE C14: SAFETY EQUIPMENT*Advisory Committee: TAC**Governance: F1 Commission / WMSC***C14.1 Fire Extinguishers**

All cars must be fitted with a fire extinguishing system which:

- a. Will discharge into the **Cockpit** only.
- b. Is approved according to the FIA Standard 8876–2022 and homologated for Class II fires, **with the exception of:**
 - i. The pressure gauge required by section 4.6 of FIA Standard 8876–2022 for pressurised systems, provided that the F1 Team supplies an on- or off-car solution to verify that the system is correctly pressurised at filling and test times.
 - ii. The electrical box required by section 4.5.1 of FIA Standard 8876–2022, provided that the F1 Team supplies an on- or off-car solution to verify that the system operates without anomaly and is ready to be activated.
 - iii. The requirements of section 4.5.2 of FIA Standard 8876–2022, provided that the activation switch installation achieves an equivalent ingress protection.
- c. Must be installed and maintained according to the manufacturer’s recommendations.

The bottle and firing mechanism must be situated within the **Survival Cell** and all extinguishing equipment must withstand fire.

The triggering system must have its own source of energy and it must be possible to operate all extinguishers should the main electrical circuits of the car fail. **The F1 Team may source its own specification of battery and energy capacity, but it must fulfil the requirements of section 3.3.2 of FIA Standard 8876–2022.**

The driver must be able to trigger the extinguishing system manually when seated normally with the safety harness fastened and the steering wheel in place.

Furthermore, a means of triggering from the outside must be combined with the circuit breaker switches described in Article C8.7.

~~The pressure gauge required by Item 4.6 of FIA Standard 8876–2022 may be replaced by a pressure sensor.~~

All extinguisher nozzles must be included in the homologation of the fire extinguishing system. At least one nozzle must be aimed at the driver's midriff.

C14.2 Rear view mirrors

C14.2.1 All cars must have two mirrors positioned symmetrically about the car’s centre plane and mounted so that the driver has visibility to the rear and both sides of the car.

C14.2.2 The reflective surface of each mirror must satisfy the following conditions:

- a. It must be contained within ~~RV-MIR-HOU~~ **RV-MIRROR-BODY** and not be obstructed by the ~~Mirror Housing~~ **Mirror Body**, ~~as defined in Article C3.6.4~~ either towards the driver or in the rearward direction.

- b. Its four edges must project orthogonally onto the edges of a vertical rectangle which is 200mm wide and 50mm high (+2mm/-0mm for both dimensions), with a radius of up to 10mm applied to each corner.
- c. Over its whole area it must:
 - i. not contain any concave parts
 - ii. be tangency continuous
 - iii. not have any normal radius of curvature less than 400mm.
- d. When cut by any Z-Plane and before any radius is applied to the corners:
 - i. the normal to the curve at its inboard end must subtend an angle of between 24deg and 28deg to the X axis, pointing towards the Y=0 plane.
 - ii. the angle between normals to the curve at its inboard and outboard ends must be greater than 8 degrees.

For the avoidance of doubt, any non-reflective parts of the mirror must be contained within the Mirror Body.

C14.2.3 **F1 Teams** will be required on request to supply the FIA with CAD data with regard to the visibility of their mirror arrangement, and the FIA will retain the right to modify the position of the volume defined in Article C3.6.4 (a) should it become apparent that the mirror position does not meet the safety requirements.

C14.3 Rear lights

C14.3.1 All cars must have three rear lights which:

- a. Have been supplied by FIA designated manufacturers.
- b. Are clearly visible from the rear.
- c. Can be switched on by the driver when seated normally in the car.

C14.3.2 The first such light must have:

- a. Its rear face on an X-Plane and at least 750mm behind $X_{DIF}=0$.
- b. The centre of its rear face on $Y=0$.
- c. The centre of its rear face between $Z=295$ and $Z=305$.

C14.3.3 Two further lights

- a. Must be fitted, one on each side of the car, within the bodywork defined in Article C3.11.2 and in full compliance with Article C3.11.2.
- ~~b. May be curved in the plane of the lens of the LED elements with a radius of not less than 200mm.~~
- b. The normal to the plane of the lens of the LED elements must be no more than 5° from the X-axis.
- c. Lie in ~~its~~ their entirety between ~~Z=500~~ $Z=700$ and $Z=870$.

- d. Respect the directionality of the lens of the LED elements, which should point in a nominally horizontal direction towards the rear of the car.
- e. Be fitted in accordance with the instructions detailed in the document [FIA-F1-DOC-Cxxx](#).

C14.3.4 Both types of rear light are classed as **SSC**, and all the relevant details can be found in the Document FIA-F1-DOC-Cxxx Appendix to the Technical and Sporting Regulations.

C14.4 Safety Tethers

C14.4.1 Wheel Tethers

Each wheel must be fitted with three tethers compliant with FIA standard 8864–2022. The sum of the three maximum absorbed energy, as per FIA Technical List n.93, must be at least 15kJ. No suspension member may contain more than two tethers.

Each tether:

- a. must have a minimum energy absorption of 3kJ.
- b. must have its own separate attachments at both ends, which:
 - i. Are able to withstand a tensile force of 70kN in any direction within a cone of 90° (included angle) measured from the load line of the relevant suspension member.
 - ii. Are able to accommodate tether end fittings with a minimum inside diameter of 15mm.
 - iii. Do not share a common fastener and are designed such that the failure of one attachment point will not lead to the direct failure of an adjacent attachment point.
- c. Must register a peak force during homologation of no greater than 70kN.

Furthermore, at least two of the three tethers must have attachment points which:

- d. On the **Survival Cell** are separated from each other by at least 300mm in the X-direction, measured between their centres.
- e. On the **Gearbox** are separated from each other by at least 250mm in the X-direction, measured between their centres.
- f. On each wheel/upright assembly are separated by at least 90° radially with respect to the rotational axis of the wheel and 100mm measured between the centres of the two attachment points.

Each **F1 Team** must supply detailed geometries which clearly show that all of the three tethers will independently prevent a wheel from making contact with a driver's head during an accident, with the **Secondary Roll Structure** fitted, assuming 40% elongation in each tether.

C14.4.3 Rear Impact Structure Tether

The rear impact structure should be attached to the **Gearbox Case** with a tether with a cross sectional area of at least 20mm², a minimum breaking strength of 24kN and a length of at least 600mm. The attachment to the **Gearbox Case** should be ahead of X_{DIF}=300, should be able to accommodate the tether with a minimum bend radius of 6mm. This fixing should withstand a load of 20kN in a rearward direction at up to 22.5° from the X-axis. The attachment to the RIS should be

behind $X_{DIF}=650$, should be able to accommodate the tether with a minimum bend radius of 6mm. This fixing should withstand a load of 20kN in a forward direction.

C14.5 Safety Harnesses

It is mandatory to wear a safety harness that has been homologated to FIA Standard 8853–2016. The safety harness must be used in accordance with the safety harness manufacturer's instructions and must be securely fixed to the car. Approved harnesses are listed in Technical List n°57.

C14.6 Driver Cooling System

C14.6.1 The driver cooling system is defined as a system, the sole purpose which, is to provide additional cooling for the driver.

The driver cooling system may use the phase change of a substance in its operation.

During a Race or Sprint Session for which a Heat Hazard has been declared;

- a. A system that uses a continuous process must be capable of extracting heat from the driver at a rate of at least 200W with an ambient temperature of 40°C.
- b. A system that uses stored thermal energy must have a reserve of at least 1.1MJ, calculated with the final reservoir temperature below 10°C.

C4.6.2 Any refrigerant must have a Global Warming Potential of less than 10.

C4.6.3 Solid CO₂ (dry ice) must not be used in the driver cooling system.

C14.6.4 The cooling medium within the driver's equipment may only be air, water, or (in exception to Appendix L Chapter III Article 2) an aqueous solution of sodium chloride, potassium chloride or propylene glycol.

C14.6.5 Subject to the approval of the FIA, parts of the driver cooling system may be placed within **RV-COCKPIT-DRIVER**, in exception to Article C12.5.4.c, or within the lower 50mm of the volume defined in Article C12.5.4.a (but not within the volume defined in Article C12.5.4.b).

C14.6.7 For the sole purpose of supplying air to a heat exchanger which is part of the driver cooling system, the aperture C3.16.1 may be enlarged, with an increase in area of 1000mm².

C14.6.8 The following fans are permitted:

- a. A fan of up to 12W for the sole purpose of drawing air through the condenser of a refrigeration system.
- b. A fan for the sole purpose of feeding cooled air into the driver's overalls.

C14.6.9 Parts of the thermal store for the driver cooling system which are in the volumes defined in Articles C13.5.1.d or C13.6.3.f must be homologated as follows.

The Thermal Store:

- a. complete and filled with coolant, must be cooled to its minimum operating temperature.
- b. must be placed between the platens of a compression testing machine. The platens must be large enough that the parts of the Thermal Store within the specified volume remain between them throughout the test.

- c. must be orientated so that the test direction is aligned with the Y-Axis for components paced in the volume defined Article C13.5.1.d or the X-Axis for components paced in the volume defined Article C13.6.3.f.
- d. must be crushed until the distance between the platens is less than 25mm.

During the test, the load must not exceed 20kN

C14.7 Lateral Safety lights

- C14.7.1** All cars must be fitted with **a two** lateral safety lights (**one** on each side of the car), which must:
- a. have been supplied by an FIA designated manufacturer.
 - b. lie within **RV-LATERAL-SAFETY-LIGHT** as positioned in Article C3.7.5.
 - c. offer an unobscured view of the highlighted surface of **RV-LATERAL-SAFETY-LIGHT** from the front and side of the car.

C14.7.2 This lateral safety light is classed as **SSC**, and all the relevant details can be found in the Document FIA-F1-DOC-Cxxx Appendix to the Technical and Sporting Regulations

C14.8 Driver's Drink System

All cars must be fitted with a system for providing the driver with drink. The system must have a capacity of between 1 litre and 1.5 litres and must be located between $X_C=-1400$ and $X_C=0$.

ARTICLE C15: MATERIALS**C15.1 General Principles**

Advisory Committee: TAC and PUAC

Governance: F1 Commission / PU Manufacturers' Governance Agreement / WMSC

- C15.1.1** Materials used in the construction of the **Formula One car** – excluding the **Power Unit** – are limited to those defined in article C15.2 and to the specific exceptions in article C15.4.
- C15.1.2** Materials and processes used or prohibited in the **Power Unit** are defined in Articles C15.6 to C15.9.
- C15.1.3** All materials used must be commercially available.
- C15.1.4** No parts of the car may be made from metallic materials that have a specific modulus of elasticity greater than 40 GPa/(g/cm³). Tests to establish conformity will be carried out in accordance with FIA Test Procedure 03/03, a copy of which may be found in the Appendix to the Technical and Sporting Regulations.
- C15.1.5** An **F1 Team** or PU Manufacturer may submit a proposal to the FIA to add or to remove a material from this article. The proposal should include mechanical characteristic, cost, and supply considerations. The proposal will be considered by the TAC or PUAC after the **F1 Teams** or PU Manufacturers have reviewed the proposal.
- C15.1.6** Materials that are a direct equivalent to permitted materials may be added by presenting justification to the FIA, who may at its absolute discretion ask more information or tests to be carried out to support the claim.
- C15.1.7** **F1 Teams** are required to make submissions of the materials that they will use on the car as part of their annual homologation submission. These shall be listed according to the categories in Article C15.2. This information will be compiled, anonymised, and circulated to the relevant group.
- C15.1.8** Unless explicitly permitted otherwise for a specific application, only material approved by the FIA Technical Department may be used on the **Power Unit**. The approval of the FIA Technical Department is conditional upon the material concerned being available on a non-exclusive basis and under normal and equivalent commercial terms to all PU Manufacturers. The approval request form must be sent by the PU Manufacturer to the FIA before the 1st of November of the preceding year. This information will be compiled, anonymised, and circulated to all PU Manufacturers by the end of March of the same year.
- C15.1.9** The whole percentage range of an element, as declared in the applicable international standard for a specific alloy, shall be inside all the limits set in these Regulations.

C15.2 Permitted Materials (Components Outside the PU Perimeter)

Advisory Committee: TAC

Governance: F1 Commission / WMSC

With the exception of materials specifically permitted for certain components, as listed in Article C15.4, only the following materials may be used:

C15.2.1 Metallic Materials – Not Used for Additive Manufacture

- a. Iron Alloys: any
- b. Aluminium Alloys:
 - i. Cast Aluminium based alloys from the 2xx, 3xx, 4xx, 5xx and 7xx series.
 - ii. Wrought Aluminium based alloys from the 1xxx, 2xxx, 3xxx, 4xxx, 5xxx, 6xxx and 7xxx series containing less than 1% Lithium.
 - iii. 2050 with a chemical composition conforming to UNS A92050.
 - iv. 2055 with a chemical composition conforming to UNS A92055.
 - v. 2099 with a chemical composition conforming to UNS A92099.
- c. Magnesium Alloys:

As defined under ASTM B107-13

 - i. UNS M18432, WE43B
 - ii. UNS M18434, WE43C
 - iii. UNS M18410, WE54A
 - iv. UNS M11800, AZ80A
- d. Ni or Co based Superalloys:
 - i. UNS N06625; W.Nr.2.4856 Inconel 625
 - ii. UNS N07718; W.Nr.2.4668 Inconel 718
 - iii. UNS N07001; W.Nr.2.4654 Waspaloy
 - iv. UNS R30035; W.Nr.2.4999 MP35N
 - v. UNS R30159 MP159
- e. Titanium Alloys:
 - i. Low-alloy titanium alloys containing at least 97.5% Ti and less than 1% of any other element.
 - ii. Grade 9 Ti3Al2.5V
 - iii. Grade 5; grade 23 TiAl6V4, Ti64
 - iv. UNS R54620, Ti6242, Ti6242Si
 - v. UNS R56260 Ti6246
 - vi. UNS R56410 Ti10-2-3
 - vii. UNS R58153 Ti15-3-3-3
 - viii. UNS R58640 Allvac 38-644
 - ix. Ti-5Al-5Mo-5V-3Cr Ti5553
 - x. Ti15Mo3Nb3Al0.2Si Timetal Ti21S

- xi. Timetal Ti1100
- xii. Ti 6Cr-5Mo-5V-4Al
- f. Copper Alloys containing less than 2.5% Beryllium
- g. Tungsten Alloys: any
- h. Particulate Reinforced Aluminium Alloy Matrix Composite
 - i. SupremEX 225XE
 - ii. SupremEX 225XF

C15.2.2 Metallic Materials Used for Additive Manufacture

Components produced by additive manufacture can be made from materials in the following list. A full list of applicable standards and criteria for acceptance of metals under the provisions of Article C15.2.5 in this list is given in the document [FIA-F1-DOC-Cxxx](#).

- a. Aluminium Alloys; AlSi10Mg, AlSi7MG, Al Cl-30AL, P339 AM, EOS Aluminium 2139 AM, Ahead CP1
- b. Aluminium Alloys with particulate reinforcing, A20X, 2024-RAM2, 6061-RAM2
- c. Aluminium-Magnesium Alloys; Scalmalloy, HRL 7A77
- d. Titanium Alloys; Grade 1, Grade 2, Ti6Al4V, Ti6AL4V ELI, Ti 5553, Ti 6242.
- e. Steel Alloys; 316, 304, MS1, 15-5PH, 17-4PH.
- f. Copper Alloys not containing Beryllium.
- g. Superalloys; Inconel 625, Inconel 718, Cobalt-Chrome.

Furthermore, the finished mass of a component made by additive manufacture should be no less than 60% of the mass of the printed component, excluding support structures.

C15.2.3 Permitted Polymer Composite Materials

- a. **Matrix Systems:** the matrix system utilised in all polymer composite materials must be based on one of the following:
 - i. Epoxy
 - ii. cyanate ester
 - iii. bismaleimide
 - iv. phenolic
 - v. polyurethane
 - vi. polyester
 - vii. Thermoset resins not derived from petrochemicals – subject to approval.
 - viii. Thermoplastic materials
- b. **Reinforcing:** reinforcing is permitted using the following materials:
 - i. Carbon fibres manufactured from polyacrylonitrile (PAN) precursor, which have:

- A nominal tensile modulus $\leq 550\text{GPa}$
- A nominal tensile strength $\leq 7100\text{ MPa}$ (i.e. up to and including that of Toray T1100 or Mitsubishi MR70)
- A density $\leq 1.92\text{ g/cm}^3$
- iii. Aramid fibres.
- iv. Poly(p-phenylene benzobisoxazole) fibres (e.g. “Zylon”).
- v. Polyethylene fibres.
- vi. Polypropylene fibres.
- vii. Glass fibres, **limited to types; E, S, Q and BF. As defined in ISO 2078:2022.**
- viii. ~~Natural Organic~~ Fibres (~~are limited to; flax, hemp, linen, cotton, bamboo~~)
- c. Core Materials:
 - i. Aluminium Honeycomb
 - ii. Meta-Aramid Honeycomb (e.g. Nomex or equivalent)
 - iii. Para-Aramid Honeycomb (e.g. Kevlar)
 - iv. Polymer foams
 - v. Polymer syntactic foams
 - vi. Balsa wood

C15.2.4 Permitted Polymer Materials

In addition to materials permitted in C15.2.3, the following polymer materials are permitted:

- a. Thermoplastics – monolithic or particulate filled.
- b. Thermosets – monolithic or particulate filled.

C15.3 Specific Prohibitions and Restrictions (Components Outside the PU Perimeter)

Advisory Committee: TAC

Governance: F1 Commission / WMSC

C15.3.1 Notwithstanding the list of permitted materials in Article C15.2, the following materials or processes are forbidden:

- a. Shape Memory Materials except for piezoelectric materials used in electrical sensors.
- b. Additive manufactured materials containing Beryllium.

C15.3.2 Notwithstanding the list of permitted materials in Article C15.2, the following materials or processes are forbidden unless listed in Article C15.4:

- a. Alloys where the combined weight of Platinum, Ruthenium, Iridium, Rhenium and Gold is more than 5%
- b. Components produced by foil metallurgy.

c. Intermetallic alloys.

C15.3.4 Suspension uprights may only be made from:

- i. wrought UNS A92014, UNS A92618, UNS A97075 or EN/AA 7022 aluminium alloys
- ii. wrought or cast titanium alloys permitted by C15.2.1.e.
- iii. particulate reinforced aluminium alloy matrix composites permitted by C15.2.1.h.
- iv. additive manufactured titanium permitted by C15.2.2.d
- v. additive manufactured aluminium permitted by C15.2.2.a or C15.2.2.b

C15.3.5 The **Primary Roll Structure** may not be made from materials with particulate reinforcing (Articles C15.2.1.h or C15.2.2.b).

C15.4 Specific Exceptions (Components Outside the PU Perimeter)

Advisory Committee: TAC

Governance: F1 Commission / WMSC

The following materials, components or processes do not have to comply with articles C15.2 or C15.2 but may be subject to restrictions elsewhere in these regulations:

- a. Monolithic Ceramic Materials may be used for; rolling elements of rolling-element bearings, **High-Pressure Fuel Pumps** elements, electrical components, **Thermal Insulation**, clutch friction materials and spherical bearings.
- b. Ceramic Matrix Composites may be used for; friction materials, seals and **Thermal Insulation**.
- c. Carbon-carbon composites may be used for friction materials.
- d. Materials used in any electrical component (e.g. control boxes, wiring looms, sensors).
- e. All seals and rubbers (e.g. rubber boots, o-rings, gaskets, any fluid seals, bump rubbers).
- f. Fluids (e.g. water, oils).
- g. Tyres.
- h. Coatings and platings (e.g. DLC, chroming) whose primary purpose is not thermal or electrical insulation and provided the total coating thickness does not exceed 25% of the section thickness of the underlying base material in all axes. In all cases, the relevant coating must not exceed 0.8mm.
- i. Paint.
- j. Adhesives.
- k. **Thermal Insulation** (e.g. felts, reflective foils or heat shields).
- l. Any currently regulated materials (e.g. fuel bladder, headrest, extinguishant, padding or plank).
- m. Materials used in any component that is supplied to an FIA Single Supply Contract.
- n. Z-pinning is allowed in composite components.
- o. Nano particles are permitted when part of a commercially available polymer or polymer resin.

- p. UNS R30006 (Stellite 6 – Cast), UNS R30106 (Stellite 6 – Sintered), UNS R30016 (Stellite 6 – Wrought) and UNSR30012 (Stellite 12) may be used on or above Z=0 (i.e. not in RV-PLANK)

C15.5 Prescribed and Homologated Laminates (Components Outside the PU Perimeter)

Advisory Committee: TAC

Governance: F1 Commission / WMSC

The following are the prescribed laminates referred to in other articles of these regulations.

C15.5.1 The materials referred to in Article C15.5.2 are defined below:

- a. CC100 – Woven carbon cloth, fibre weight between 50gsm and 150 gsm, epoxy prepreg
- b. KC60 – Woven aramid cloth, fibre weight 60gsm, epoxy prepreg
- c. KC170 – Woven aramid cloth, fibre weight 170gsm
- d. R135 – 135gsm elastomeric material
- e. R350 – 350gsm elastomeric material
- g. CC-UHS – Woven carbon cloth, fibre $F_{tu} > 6250\text{MPa}$, epoxy prepreg

C15.5.2 The prescribed laminates in use throughout the Regulations are listed below:

- a. **PL-HALO:** [KC60, CC100, KC60] stacking sequence is free.
- b. PL-ANTI-SPLINTER may be one of the three specifications listed below:
 - i. Laminate Type **A** – a laminate where more than 50% by weight of the reinforcing is: aramid, poly(p-phenylene benzobisoxazole) (e.g. “Zylon”), polyethylene, polypropylene or natural fibres. In this case, no additional precautions are required.
 - ii. Laminate Type **B** – Laminates not covered by **A** and with areal weight of reinforcing up to 1000gsm: [**B**/2, R135, **B**/2] where **B**/2 is half the laminate ± 1 ply.
 - iii. Laminate Type **C** – Laminates not covered by **A** and with areal weight of reinforcing is greater than 1000gsm: [**C**/2, R350, **C**/2] where **C**/2 is half the laminate ± 1 ply.
- c. **PL-HEADREST:** [KC60, KC60]

C15.5.3 The homologated laminates used in the **Survival Cell** are listed below. Representative panels must resist the specified load when it is applied through a rigid pad measuring 100mm x 130mm. Details of the test procedure are given in the document [FIA-F1-DOC-C002](#). The construction of these panels is OSC.

Where a laminate is of sandwich construction;

- i. The areal weight of reinforcing in the outer skin, must be as great as, or greater than that in the inner skin.
- ii. The **core** must be aluminium honeycomb with a thickness of at least 6mm.
- iii. Each skin must include plies of **CC-UHS** with an areal weight of reinforcing of at least 800gsm.
- iv. the test load must be applied to the outer skin.

a. **HL-FWD-SC:**

A laminate of sandwich construction. A representative test panel must resist an intrusion load of 325kN.

b. **HL-COCKPIT-SIDE:**

A representative test panel must resist an intrusion load of 440kN.

c. **HL-COCKPIT-FLOOR:**

A representative test panel must resist an intrusion load of 325kN.

d. **HL-FC-SIDE:**

A laminate of sandwich construction. A representative test panel must resist an intrusion load of 325kN.

C15.6 Materials, processes and construction – General (Components inside the PU Perimeter)

Advisory Committee: PUAC

Governance: PU Manufacturers' Governance Agreement / WMSC

C15.6.1 Unless explicitly permitted for a specific application, the following materials may not be used on the **Power Unit**:

- a. Magnesium based alloys.
- b. Metal Matrix Composites (MMC's) containing more than 2.0% volume/volume of other ceramic, metallic, carbon or intermetallic phase which is not soluble in the liquid phase at 100°C above the melting point of the metallic matrix.
- c. Intermetallic materials.
- d. Alloys containing more than 5% by weight of Platinum, Ruthenium, Iridium or Rhenium.
- e. Copper based alloys containing more than 2.2% Beryllium
- f. Any other alloy class containing more than 0.25% Beryllium.
- g. Tungsten base alloys.
- h. Ceramics and ceramic matrix composites.
- i. Aluminium based alloys containing more than 1.0% weight Lithium (Li).
- j. Materials which at least one element during production is a nanomaterial.
- k. **Thermal Insulation** containing unbound nanomaterials.
- l. Material with a density exceeding 18,400 kg/m³.
- m. Aluminium based alloys containing more than 1.0% weight Silver (Ag).
- n. Polymer composite material not listed in C15.2.3 except Metallic reinforced polymer.

C15.6.2 For coatings, the restrictions in Article C15.6.1 do not apply to coatings provided the total coating thickness must not exceed 25% of the section thickness of the underlying base material in all axes.

In all cases, other than under Article C15.6.3(b), the relevant coating must not exceed 0.8mm.

Where the coating is based on Gold, Platinum, Ruthenium, Iridium or Rhenium, the coating thickness must not exceed 0.035mm.

Graphene is not permitted in any coating.

C15.6.3 The restrictions in Article C15.6.1(h) do not apply to the following applications:

- a. Any component whose primary purpose is for electrical or **Thermal Insulation**.
- b. Any coating whose primary purpose is for **Thermal Insulation** of the outside of the exhaust system.

C15.6.4 For Aluminium-based alloy, in addition to the restrictions in article C15.6.1(b), TiB₂ is only permitted up to a maximum of 0.3% v/v. *Additionally AMS 4471A, AMS 4482 and AMS 7033 are authorized.*

C15.6.5 The creation of a textured surface using an energy beam (e.g., electron or laser beam) or photo-chemical etching may not be used on the **Power Unit**, except for part marking purposes.

C15.6.6 For all seals and rubbers, the restrictions in Article C15.6.1 do not apply (e.g., rubber boots, O-rings, gaskets, any fluid seals, bump rubbers).

C15.6.7 An approach aiming to respect the REACH and ROHS standards shall be actively pursued by the manufacturers.

C15.7 Materials and construction – Components (Components inside the PU Perimeter)

Advisory Committee: PUAC

Governance: PU Manufacturers' Governance Agreement / WMSC

C15.7.1 Pistons must be produced from one of the following iron-based alloys: AMS 6487, 15cdv6, 42CrMo4, X38CrMoV5-3.

C15.7.2 Piston pins must be manufactured from an iron-based alloy and must be machined from a single piece of material.

C15.7.3 Connecting rods must be manufactured from iron or titanium-based alloys and must be machined from a single piece of material with no welded or joined assemblies (other than a bolted big end cap or an interfered small end bush).

C15.7.4 Crankshafts must be manufactured from an iron-based alloy.

No welding is permitted between the front and rear main bearing journals.

Crank counterweights assembled to the crankshaft may be manufactured in a Tungsten based material.

C15.7.5 Camshafts must be manufactured from an iron-based alloy.

Each camshaft and lobes must be machined from a single piece of material.

No welding is allowed between the front and rear bearing journals.

C15.7.6 Valves must be manufactured from TiAl intermetallic materials or from alloys based on Iron, Nickel, Cobalt, Titanium. Hollow valves (e.g., sodium, or similar, filled for cooling) are permitted for the exhaust only, but the main cavity created must be a cylindrical feature of constant diameter. Machined features to facilitate manufacture and assembly are allowed above and below the main cavity, however such features must not create a volume that extends beyond a virtual plain cylinder positioned on the valve centreline with a diameter which is 1.0 mm greater than that of the main cavity.

In addition, the restrictions detailed in Articles C15.6.2 and C15.1.4 do not apply to the intake and exhaust valves.

C15.7.7 Reciprocating and rotating components:

- a. Reciprocating and rotating components must not be manufactured from graphitic matrix, metal matrix composites or ceramic materials, this restriction does not apply to the **clutch** discs and any seals.
- b. Rolling elements of rolling element bearings must be manufactured from an iron-based alloy or from a ceramic material.
- c. All timing gears between the crankshaft and camshafts (including hubs) must be manufactured from an iron-based alloy.
- d. **High Pressure Fuel Pump** elements may be manufactured from a ceramic material.
- e. Torsional damper elements may be manufactured in a Tungsten based material.

C15.7.8 Static components:

- a. Other than **Inserts** within them, engine crankcases including sump, **Cylinder Heads** and cylinder head cam covers must be manufactured from aluminium or iron-based alloys.
- b. On the crankcase including sump, **Cylinder Head** and cylinder head cam cover, composite or metallic materials are permitted for local repairs to components following damage or failure and after consultation with all PU manufacturers. The total area should in any case not exceed 100cm² and the thickness is limited to 3mm. Composite repairs must not be present on the components used during the following Championship season.
- c. Any metallic structure whose primary or secondary function is to retain lubricant or coolant within the engine must be manufactured from an iron-based alloy or an aluminium alloy.
- d. All threaded fasteners must be manufactured from Waspaloy, Rene 41, Inconel 718, A286, PH 13-08Mo, 35NiCrMo16, 30NiCrMo16, AISI H11, 17-4PH, UNS S32205/S31803, 42CrMo4 or any steel covered by the ISO 898-1 and ISO 898-2. Additional materials are authorized for the following three functions:
 - i. Fasteners whose primary function requires them to be an electrical insulator may be manufactured from ceramic or polymeric materials.
 - ii. Fasteners that are used in **Electronic Control Units** may be manufactured from aluminium or copper-based alloys or polymeric (plastic) materials.

- iii. Fasteners used between the **Cylinder Head** and crankcase, crankcase upper and lower, conrod and crankshaft counterweight bolts may be manufactured from AMS5758, AMS5844, AMS5845 and AMS5937 materials.
- e. Valve seat **Inserts**, valve guides and any other bearing component may be manufactured from metallic infiltrated pre-forms with other phases which are not used for reinforcement.
- f. **ICE Ballast** may be manufactured in a Tungsten based material.
- g. Only one **Cylinder Head** is permitted for each bank and each **Cylinder Head** must be made from a single piece of material with the exception of **inserts** defined in Article 5.1 §.7 and must include inlet ports, exhaust ports and all water cores and/or water passages above the **top deck**.
- h. The plenum must be made from polymer composite material with the exception of **inserts**.

C15.8 Materials and construction – Pressure charging and exhaust systems (Components inside the PU Perimeter)

Advisory Committee: PUAC

Governance: PU Manufacturers' Governance Agreement / WMSC

- C15.8.1 All components of the **Engine Exhaust System**, turbine, turbine housing and **Wastegate** exit housing that are in contact with the main exhaust gas flow must be manufactured from an Iron or Nickel based alloy.
- C15.8.2 Static components that are neither in the exhaust system nor in the compressor line must be manufactured from iron-based alloys, aluminium alloys or titanium alloys.
- C15.8.3 The restrictions detailed in article C15.6.1 i) do not apply to the compressor housing (from **Compressor Inlet** variable geometry intake device(s) if present to **Compressor Outlet(s)**) which must be manufactured from aluminium-based alloy containing up to 2.5% weight Lithium.
- C15.8.4 The restrictions detailed in article C15.6.1 i) do not apply to the compressor wheel, which must be manufactured from aluminium-based alloy containing up to 2.5% weight Lithium or from Titanium.
- C15.8.5 Measures must be taken to ensure that in the event of failure of the turbine wheel any resulting significant debris is contained by and within the turbine housing, except in the case of an axial failure where this debris must be contained within the turbine housing and/or tailpipe assembly.
- C15.8.6 Nickel Alloys limited to Inconel 625, 625 LCF and 718 on the exhaust primaries / secondaries / flange / brackets / turbine housing
- C15.8.7 Additive manufacture is only permitted in three areas within the exhaust assemblies as defined in 5.1.20 (see drawing 8 in Appendix C3 is a representation of these constraints, included for reference only):
 - a. One stub/flange element per primary at the connection to the **Cylinder Head**. The maximum dimension of this additive element in any direction is 150mm.
 - b. One 3-into-1 element per bank joining the primaries to the secondary. The maximum dimension of this additive element in any direction is 230mm.

- c. One connection between the secondary and the **TC** per bank. The maximum dimension of this additive element for transition to **TC** and **Wastegate** mounting in any direction is 150mm.

C15.8.9 exhaust insulation may not use ceramic matrix composite (CMC) or polymer composite material (PMC).

C15.9 Materials and construction – Energy recovery, storage systems and electronic systems (Components inside the PU Perimeter)

Advisory Committee: PUAC

Governance: PU Manufacturers' Governance Agreement / WMSC

C15.9.1 All metallic casings for the energy recovery and storage systems must be manufactured in aluminium-based alloy and must comply with all aspects of Article C15.6 except for power electronic cooling base plate where metal matrix composite may be used.

C15.9.2 All casings for electronic systems, including break up boxes, with exception of the ERS and storage system must be manufactured from polymeric material or aluminium based alloys.

C15.9.3 Energy storage devices are not subject to Articles C15.6.1a), b), c) and h) nor to C15.6.2.

C15.9.4 Permanent magnets in electrical machines are not subject to Articles C15.6.1 a), b), c) or h) nor to Article C15.6.2.

C15.9.5 Soft electromagnetic materials used in electrical machines are not subject to Articles C15.6.1 a), b), c) or h) nor to Article C15.6.2. Cobalt concentration is limited to 10% on soft magnetic alloys. Concentration up to 49% is permitted providing that all end-of-life cobalt is recycled. In addition, any cobalt used must come from an ethical source.

C15.9.6 Electronic components contained inside electronic units are not subject to any material restriction.

C15.9.7 **ES Cells** materials are not subject to Article C15.6.1 j).

ARTICLE C16: FUEL AND ENGINE OIL

Advisory Committee: PUAC

Governance: PU Manufacturers' Governance Agreement / WMSC

C16.1 Basic principles

- C16.1.1** The purpose of this Article is to ensure that the fuel and engine oil used in Formula One correspond to what these terms are generally understood to mean.
- C16.1.2** With regard to fuel, the detailed requirements of this Article are intended to ensure the use of Advanced Sustainable (AS) fuels comprising solely AS components, that are composed of certified compounds and refinery streams and fuel additives and to prohibit the use of specific power-boosting chemical compounds. Co-processing of these certified compounds or refinery streams is not permitted. All AS components and fuels must be segregated from non-sustainable components and fuels at all times. The final, blended fuel must achieve a greenhouse gas (GHG) emissions savings, relative to fossil-derived gasoline, of at least that defined for the transport sector in the EU Renewable Energy Directive RED⁽¹⁾, which was current on January 1st in the year prior to the relevant Formula One Championship. The GHG savings calculation takes into account any net carbon emissions from land-use change, the energy used in harvesting and transporting the biomass and the production and processing of the advanced sustainable component. In any process where sustainable energy is used, this must be surplus to the local domestic requirements. Where available, GHG emission savings will be taken from the current EU Renewable Energy Directive (RED) or other equivalent, internationally recognised sources. The use of these compounds and refinery streams in F1 fuel will be dependent on evidence indicating that the supplier is genuinely developing these compounds for use in commercial fuels and that they are available from plants capable of producing at least 5m³ per year or are commercially available at similar volumes from a third party. Acceptable compounds and compound classes are defined in Appendix C1 Part B (under **Additive, Aromatics, Diolefins, Naphthenes, Olefins, Oxygenates** and **Paraffins**) and C16.4.3. In addition, to cover the presence of low-level impurities, the sum of components lying outside Appendix C1 Part B and Article C16.4. 3.3 definitions are limited to 1% max m/m of the total fuel.
- ⁽¹⁾ Article 29, Section 10(c) of Directive (EU) 2018/2001 for biofuels, and Article 25, Section 2 for RFNBO
- C16.1.3** Only approved fuel (Article C16.5) may be released into the engine **Combustion Chamber** by the **Fuel Injector** (5.1.12).
- C16.1.4** Only ambient air may be mixed with the fuel as an oxidant.
- C16.1.5** The function of an engine oil is to lubricate moving parts, to improve efficiency by reducing friction and to reduce wear. It also cleans, inhibits corrosion, improves sealing, and cools by carrying heat away from parts. Engine oil should not enhance the properties of the fuel nor energize the combustion. The presence of any component that cannot be rationally associated with the defined functions of the engine oil will be deemed unacceptable.
- C16.1.6** Any fuel or engine oil, which appears to have been formulated in order to subvert the purpose of this regulation, will be deemed to be outside it.

C16.1.7 All **F1 Teams** must be in possession of a Material Safety Data Sheet for each type of fuel or engine oil used. This sheet must be made out in accordance with EC Directive 93/112/EEC and all information contained therein strictly adhered to.

16.1.8 The following components, irrespectively of their location inside the car, can only be lubricated with the oil as defined in article 16.1.5:

- - **ICE**
- - Turbocharger
- - MGUK mechanical transmission
- - MGUK

Greases are not considered as part of this restriction.

16.1.9 Only one oil specification, as defined in 16.1.5, is allowed inside the PU perimeter, with the following exceptions:

- Hydraulic fluid, only for the following devices under their normal and intended operation:
 - Actuators and relative control valves, as described in Appendix 3 Table 1 items 649 and 654
 - Hydraulic pump, if mechanically driven by the **ICE**, as described in Appendix 3 Table 1 item 632
 - Hydraulic lines associated with the above, as described in Appendix 3 Table 1 items 632 to 676.
- ERS fluid used for the normal and intended operation of the following PU Area as listed in the Appendix 3: ERS cooling, **MGU-K**, **ES** and **PU-CE**.

Greases are not considered as part of this restriction.

16.1.10 Excluding fuel, hydraulic fluid, ERS fluid and engine oil as defined in 16.1.5, any other liquid inside the PU perimeter can only have the function of coolant/thermal exchange, and cannot act as a lubricant, with the only possible exception of lubricating its own pump(s) and valve(s).

C16.2 Fuel properties

The only fuel permitted is petrol having the following characteristics:

Property	Units	Min	Max	Test Method
RON		95.0 ⁽¹⁾	102.0 ⁽¹⁾	ISO 5164/ ASTM D2699
Sensitivity (RON-MON)			15.0 ⁽¹⁾	ISO 5164/ ASTM D2699 ISO 5163/ ASTM D2700
LHV	MJ/kg	38.0	41.0	GC
Density (at 15°C)	kg/m ³	720.0	785.0	ISO 12185/ ASTM D4052
Methanol ⁽²⁾	% v/v		3.0	EN 1601 or EN 13132 or EN ISO 22854
Oxygen	wt%	6.70	7.10	Elemental Analysis
Nitrogen	mg/kg		500	ASTM D 5762
Benzene	wt%		1	GCMS

DVPE	kPa	45	68	EN130161
Lead	mg/l		5	ASTM D 3237 or ICPOES
Manganese	mg/l		2	ASTM D 3831 or ICPOES
Metals (excluding alkali metals)	mg/l		5	ICPOES
Oxidation Stability	minutes	360		ASTM D 525
Sulphur	mg/kg		10	EN ISO 20846
Electrical conductivity	pS/m	200		ASTM D 2624
Distillation Characteristics:				
At E70°C	% v/v	20.0	52.0	ISO 3405/ ASTM D86
At E100°C	% v/v	40.0	80.0	ISO 3405/ ASTM D86
At E150°C	% v/v	75.0		ISO 3405/ ASTM D86
Final Boiling Point	°C		210	ISO 3405
Distillation Residue	%v/v		2	ISO 3405
A correction factor of 0.2 for MON and RON shall be subtracted for the calculation of the final result in accordance with EN 228: 2012 A stabilising agent must be added				

The fuel will be accepted or rejected according to ASTM D 3244 with a confidence limit of 95%.

C16.3 Composition of the fuel

C16.3.1 The composition of the petrol must comply with the specifications detailed below:

Component	Units	Min	Max	Test Method
Aromatics	wt%		40	GCMS
Olefins	wt%		17	GCMS
Total diolefins	wt%		0.1	GCMS
Total styrene and alkyl derivatives	wt%		0.1	GCMS

In addition, the fuel must contain no substance which is capable of exothermic reaction in the absence of external oxygen.

C16.3.2 The total of individual hydrocarbon components present at concentrations of less than 5% m/m of the total fuel must be at least 30% m/m of the hydrocarbon component of the fuel.

C16.3.3 The only oxygenates permitted are paraffinic monoalcohols and paraffinic monoethers with a final boiling point below 210°C.

C16.3.4 An additive package from non-sustainable sources, comprising **Additives** (as defined in Appendix C1 Part B), and **Denaturants** (as defined in Appendix C1 Part B) from non-sustainable sources may be used, at a total combined concentration of no more than 1.0% m/m of the blended fuel. The presence of any non-sustainable component that cannot be rationally associated with the defined functions of the additive package or the denaturant will be deemed unacceptable.

C16.4 Fuel approval

C16.4.1 Before any fuel may be used in the Formula One Championship:

- a. The supplier must comply with the requirements set in Appendix C8, Paragraph 2.1.
- b. Two separate five litre samples, in suitable containers, must be submitted to the FIA for analysis and approval.
- c. ~~Certification must be presented to the FIA, from a recognised body, assuring the origin and the calculated GHG reduction of each AS compound and AS refinery stream blended into any Formula One fuel blend submitted to the FIA for approval. Each AS fuel component and/or AS refinery stream must undergo a compliance process conducted by an independent sustainability management scheme company appointed by the FIA. This is to verify that it meets the FIA's advanced sustainable requirements including its origin. As part of this process, recognised voluntary certification schemes may be accepted to demonstrate proof of sustainability of these AS fuel component and/or AS refinery streams. The final blended fuel, made exclusively from these AS components, AS refinery streams, and the components defined in C16.3.4, must also undergo a similar segregated compliance process conducted by the same FIA-appointed sustainability management scheme company. This will validate the traceability of each AS component and AS refinery stream in the blended fuel, its calculated GHG reduction, and ensure intellectual property is protected. This process is described in detail in FIA-F1-DOC-C00X.~~
The sustainability management scheme company will guarantee consistent, uniform and stable decisions building on widely accepted sustainability principles. Upon successful completion of this compliance process, the FIA will issue the corresponding approval certificate.
- d. The fuel must be shown to be compatible with the fuel bladder and seal materials used by all **F1 Teams** or PU Manufacturers that will be using the fuel by passing the tests specified in the document **FIA-F1-DOC-Cxxx**.

C16.4.2 No fuel may be used in a **Competition** without the prior written approval of the FIA.

C16.5 Fuel sampling and testing at a Competition

C16.5.1 All samples will be taken in accordance with the FIA Formula One fuel sampling procedure, a copy of which may be found in the document **FIA-F1-DOC-Cxxx**.

C16.5.2 Fuel density will also be checked and must be within 0.15% of the figure noted during preapproval analysis.

C16.5.3 Fuel samples taken during a **Competition** will be checked for conformity by using a gas chromatographic technique, which will compare the sample taken with an approved fuel. Samples which differ from the approved fuel in a manner consistent with evaporative loss, will be considered to conform. However, the FIA retains the right to subject the fuel sample to further testing at an FIA approved laboratory.

C16.5.4 GC normalised peak areas of the sample will be compared with those obtained from the reference fuel. Variations in any given normalised peak area (relative to those of adjacent peaks of a similar size) which are greater than 12%, or an absolute amount greater than 0.10% for compounds present at concentrations below 0.8%, will be deemed not to comply.

If a peak is detected in a fuel sample that was absent in the corresponding reference fuel, and its peak area represents more than 0.10% of the summed peak areas of the fuel, the fuel will be deemed not to comply.

If the deviations observed (above) by GC indicate that they are due to mixing with another Formula One fuel, which has been approved by the FIA for use by the team, the fuel sample will be deemed to comply, provided that the adulterant fuel is present at no more than 10% in the sample. Any systematic abuse of mixed fuels will be deemed not to comply.

C16.6 Engine oil definitions

Engine oil (serving the purpose stated in Article C16.1.5) must comprise base oils and additives as defined below.

Base Oil General:

- a. A base oil is a base stock or blend of base stocks.
- b. A base stock is a lubricant component that is produced by a single manufacturer. Base stocks may be manufactured using a variety of different processes including but not limited to distillation, solvent refining, hydrogen processing, oligomerization, esterification, and rerefining.

All base stocks are divided into five general categories:

- a. Group I base stocks contain less than 90 percent saturates and/or greater than 0.03 percent sulphur and have a viscosity index greater than or equal to 80 and less than 120 using the test methods specified in the table below.
- b. Group II base stocks contain greater than or equal to 90 percent saturates and less than or equal to 0.03 percent sulphur and have a viscosity index greater than or equal to 80 and less than 120 using the test methods specified in the table below.
- c. Group III base stocks contain greater than or equal to 90 percent saturates and less than or equal to 0.03 percent sulphur and have a viscosity index greater than or equal to 120 using the test methods specified in the table below.
- d. Group IV base stocks are polyalphaolefins (PAO).
- e. Group V base stocks include all other base stocks not included in Group I, II, III, or IV.

The Analytical Methods for Base Stock are defined below:

Property	Test Method
Saturates	ASTM D2007
Viscosity index	ASTM D2270
Sulfur (use one listed method)	ASTM D1552 ASTM D2622 ASTM D3120 ASTM D4294 ASTM D4927

Additives are defined as the chemical compounds added to the base oil in small concentrations in order to improve the performance characteristics of the engine oil.

C16.7 Engine oil properties

The engine oil must comply with the following characteristics:

Property	Units	Min	Max	Test Method
Kinematic Viscosity (100°C)	cSt	2.8		ASTM D445
HTHS Viscosity at 150°C and Shear Rate of 10 ⁶ s ⁻¹	mPa.s	1.4		ASTM D4741
Initial Boiling Point	°C	210		ASTM D7500
Flashpoint	°C	93		ASTM D3828

The oil will be accepted or rejected according to ASTM D 3244 with a confidence limit of 95%.

C16.8 Composition of the engine oil

C16.8.1 In the event that the initial boiling point test (ASTM D7500) suggests the presence of compounds with a boiling point of less than 210°C the sample will be further analysed by GCMS. The total of any components with boiling points less than 210°C must not exceed 0.5% m/m.

C16.8.2 The engine oil must not contain any organometallic petrol additives or other octane boosting petrol additives.

C16.9 Engine oil approval

C16.9.1 Before any engine oil may be used in the Formula One Championship:

- The supplier must comply with the requirements set in Appendix C8, Paragraph 2.1.
- Two separate one litre samples, in suitable containers, must be submitted to the FIA for analysis and approval.

C16.9.2 No engine oil may be used in a **Competition** without the prior written approval of the FIA.

C16.9.3 In addition to the engine oils approved for use in a **Competition**, one type of dyno engine oil may be approved by the FIA.

C16.10 Sampling and testing at a Competition

C16.10.1 Each **F1 Team** must declare, prior to every **Competition**, which oil will be used in each of their engines during the **Competition**.

C16.10.2 For reference purposes, before any oil may be used at a **Competition**, a sample must be submitted to the FIA together with the oil reference number.

C16.10.3 Engine oil samples taken during a **Competition** will be checked for conformity by using a Fourier transform infrared (FTIR) technique, which will compare the sample taken with that submitted at the start of the **Competition**. Samples which differ from the reference engine oil in a manner consistent with fuel dilution, engine fluids contamination and oil ageing as a result of normal engine operation, will be considered to conform. Samples which differ from the reference engine oil in a manner consistent with the mixing with other engine oils, which have been approved by the FIA for use by the team at a **Competition**, will be deemed to comply, provided that the adulterant oils are in total present at no more than 10% in the sample. This tolerance will also be applicable for the mixing with the approved dyno engine oil but only for a new engine during the **Competition** at which it is first used. However, the FIA retains the right to subject the oil sample to further testing at an FIA approved laboratory.

C16.11 Recycling of Engine Oil

C16.11.1 All used engine oils must be collected for recycling.

ARTICLE C17: COMPONENTS' CLASSIFICATION

Advisory Committee: TAC

Governance: F1 Commission / WMSC

C17.1 General Principles**C17.1.1 Classification:**

- a. Subject to Article ~~C17.2.4~~ C17.1.1 (d), all components used in **Formula One cars** and all equipment used to support an **F1 Team's** operations during a Championship shall be classified as a Listed Team Component (**LTC**), a Standard Supply Component (**SSC**), a Transferable Component (**TRC**), a Free Supply Component (FSC), a Defined Specification Component (**DSC**), an Open Source Component (**OSC**) or a Not Transferable Open Source Component (**OSCNT**), each as defined in Article ~~C17.3-C17.7~~ C17.2-C17.6 (inclusive).
- b. Unless otherwise specified, such components/equipment will be classified as **LTC**.
- c. All Aerodynamic Components described in Article C3 are **LTC**, unless specifically defined as **SSC**, or **OSCNT**
- d. **Power Unit** components shown as "INC" in the column "Supply Perimeter" of the table in Appendix C4 do not fall under any of the four categories set out in this Articles C17.
- e. In cases of doubt, the FIA should be consulted and shall determine the classification of a particular component or piece of equipment, should that differ from the default classification mentioned in Article ~~C17.2.4~~ C17.1.1 (b) above.

C17.1.2 For the purposes of the remaining provisions of this Article C17, any reference to any **F1 Team** shall ~~include (a) any~~ be a reference to the **F1 Team** together with the approved ~~Associate Technical Partner~~ **Technical Partner** of such **F1 Team**. ~~An approved Technical Partner is not considered a separate party to its associated F1 Team, rather the F1 Team and its approved Technical Partner will together be considered as a single entity, being the F1 Team. ; and (b) any external entity (i) working on behalf of an F1 Team or (ii) working for its own purposes and subsequently providing the results of its work to an F1 Team;~~

; and (b) any external entity (i) working on behalf of an **F1 Team** or (ii) working for its own purposes and subsequently providing the results of its work to an **F1 Team**.

C17.1.3 For the purposes of the remaining provisions of this Article C17, any reference to a "component" may also refer to complete assemblies.

C17.1.4 No **F1 Team** may use movement of personnel (whether employee, consultant, contractor, secondee or any other type of permanent or temporary personnel) with another **F1 Team**, either directly or via an external entity, for the purpose of circumventing the requirements of this Article C17.

C17.1.5 From time to time the FIA may request that an **F1 Team** shares certain information in connection with this Article C17 with the FIA (a) so that the FIA may share with the other **F1 Teams** for safety reasons only, or (b) to assist the FIA in considering future amendments to the Regulations, subject in each case to receiving the appropriate undertaking of confidentiality from the FIA.

- C17.1.6** Except as otherwise expressly permitted by these Regulations or by the FIA, no **F1 Team** may directly or indirectly disclose or transfer any Intellectual Property to another **F1 Team** that is reasonably likely to impact upon the performance of the receiving **F1 Team**, and no **F1 Team** may directly or indirectly obtain (by any means) the same from another **F1 Team**.
- C17.1.7** Where an **F1 Team** is made responsible under these Regulations for raising any issues of safety, incompatibility and/or reliability of a component that it uses on its car, it shall not make any claim against any other party that is inconsistent with that responsibility.
- C17.1.8** **F1 Teams** may make available to other **F1 Teams** test facilities and equipment such as (but not limited to) wind tunnels or dynamometers. The Intellectual Property involved in the operation of such shared facilities may be used by and/or disclosed to the sharing party but the results of any experimental or test work carried out on such facilities may only be used by the originator of the work. Where facilities are shared, robust processes must be put in place to ensure there is no transfer of Intellectual Property through common personnel and that all data can only be accessed by the originator of the work. Any such sharing of facilities must be declared to the FIA with a full description of the work that will be carried out, and also of the processes that will be put in place in order to avoid an exchange of information that could lead to the transfer of knowledge leading to the performance enhancement of an **LTC** (as required by Article ~~C17.3.4~~ C17.2.4), or a **TRC** (as required by Article ~~C17.5.8~~ C17.4.8) or an **OSC** (as required by Article ~~C17.6.11~~ C17.5.11).

C17.1.9 A “**Specialist Supplier**”, is a third party who supplies specialist engineering services to **F1 Teams**.

A Specialist Supplier;

- Must not be a **Related Party** to an **F1 Team**
- Must be approved as a **Specialist Supplier** by the **FIA**
- May only act as a **Specialist Supplier** for components for which it has been approved.

Where a **Specialist Supplier** provides services outside the scope of its approved specialisation, it will be considered as a third party supplier under the requirements of C17.2 and C17.4.

C17.1.10 A “**Technical Partner**”, with respect to an **F1 Team** in the **Championship**, is a party who is nominated by an **F1 Team** to undertake all kinds of work, including work on **LTC**, **TRC**, or **FSC** components.

A Technical Partner;

- Must be a **Related Party** of the **F1 Team**
- Can only be a **Technical Partner** to a single **F1 Team** and must be the sole **Technical Partner** to that **F1 Team**
- Must be declared on the entry form to the **Championship** and approved by the **FIA**

The **F1 Team** is responsible for the compliance of its **Technical Partner** with the **Regulations**

C17.2 Listed Team Components (LTC)

C17.2.1 “**Listed Team Components**” (**LTC**) are components whose design, manufacture and Intellectual Property ~~is must be~~ owned and/or controlled by a single **F1 Team** ~~or its agents~~ on an exclusive basis **within Formula One** (including, without limitation, the components identified as such in Appendix C6).

C17.2.2 A **F1 Team** may only use **LTCs** in its **Formula One cars** ~~that it has designed (including, for the avoidance of doubt, its three-dimensional shape and the evolution history leading to it, any preliminary designs, simulations, wind tunnel tests, and analysis) itself~~ for which the **F1 Team** has undertaken the **Concept Design**.

The **F1 Team** may **Outsource** ~~any R&D, engineering the~~ **Engineering** and/or ~~CAD design and/or the manufacture~~ **Manufacturing** of any **LTC** to a third party ~~(including, for the avoidance of doubt, an Associate of such F1 Team)~~ provided that:

- a. the **F1 Team** retains the exclusive right to use the **LTC** in Formula One for so long as it competes in Formula One;
- b. the third party to whom ~~manufacture~~ the **Engineering** or **Manufacturing** of the **LTC** is Outsourced ~~may is not be~~ another **F1 Team** or ~~an Associate~~ a **Related Party** to another **F1 Team**; ~~and~~
- c. the third party, ~~excluding~~ **Specialist Suppliers**, to whom ~~design~~ the **Engineering** of the **LTC** is **Outsourced** ~~may not be another F1 Team, an Associate to another Competitor, or a party that directly or indirectly designs LTCs or TRCs for any other another~~ does not directly or indirectly carry out ~~for another F1 Team~~, or the **Technical Partner** to another **F1 Team**, the **Concept-Design, Engineering, or Manufacturing** of an **LTC, TRC or FSC** that is in the same Group in Table 2 of Appendix C6 as the component in question;
- d. the **Specialist Supplier** to whom the **Engineering** or **Manufacturing** of the **LTC** is **Outsourced** only provides these services for components for which the **Specialist Supplier** is approved; and
- e. the **F1 Team** declares to the **FIA**, all **Engineering** carried out on **LTCs** by a third party.

C17.2.3 Although it is permissible to be influenced by the design or concept of an **F1 Team's LTC** using information that must potentially be available to all **F1 Teams**, this information may only be obtained at **Competitions** or **TCCs** (as defined respectively in Appendices A1 and B1), and no **F1 Team** may design its **LTCs** based on “reverse engineering” of another **F1 Team's LTC**. For the purpose of this Article, “reverse engineering” shall mean:

- a. The use of photographs or images, combined with software that converts them to point clouds, curves, surfaces, or allows CAD geometry to be overlaid onto or extracted from the photograph or image
- b. The use of stereophotogrammetry, 3D cameras or any 3D stereoscopic techniques
- c. Any form of contact or non-contact surface scanning
- d. Any technique that projects points or curves on a surface so as to facilitate the reverse-engineering process

In cases where isolated features of an **F1 Team's LTC(s)** may closely resemble the features of another **F1 Team's LTC(s)**, it will be the role of the FIA to determine whether this resemblance is the result of reverse engineering or of legitimate independent work. The following further provisions apply:

- e. All **F1 Teams** must provide to the FIA, upon request, any data or other information that is required to demonstrate compliance with this Article.

- f. For all LTCs used during the Championship, the restrictions described in this Article apply to their entire design process, including actions carried out before the calendar year of the Championship.
- g. The FIA may issue guidance from time to time to define more specifically the requirements and constraints of this Article.

C17.2.4 No **F1 Team** may, either directly or via a third party:

- a. pass on any information in respect of its **LTC** (including but not limited to data, designs, drawings, or any other Intellectual Property) to another **F1 Team** or receive any information from another **F1 Team** in respect of that **F1 Team's LTC**; or
- b. receive consultancy or any other kind of services from another **F1 Team** in relation to **LTC**, or supply any such services to another **F1 Team**; or
- c. pass any methodology which can be used to enhance the performance of **LTC** (including but not limited to simulation software, analysis tools, etc.) to another **F1 Team**, or receive any such methodology from another **F1 Team**.

Notwithstanding the provision of this Article, Supplying Power Unit Manufacturers or **Supplying Teams** of **TRCs** may carry out the assembly of the components they supply with adjacent **LTC** components of the **Customer Team**. In such cases, the Customer **Team** may provide the minimal assembly information of the LTCs they need to assemble to the Supplying **F1 Team** or **Power Unit** Manufacturer. The FIA must approve such a transaction to its absolute discretion and must be satisfied that it is not used as a means to circumvent the provisions of Article ~~C17.3~~ **C17.2**.

C17.2.5 An **F1 Team** ~~(for its agents)~~ must have exclusive ownership of (or the **F1 Team** must have the exclusive right to use in the Championship) any and all rights, information or data of any nature (including but not limited to all aspects of the design, manufacturing, know-how, operating procedures, properties and calibrations) in respect of the **LTC** in its **Formula One cars**. However, notwithstanding the foregoing:

- a. the use of specialist Intellectual Property or technology ~~of third parties belonging to Specialist Suppliers~~ is permitted in respect of **LTC**, provided that this Intellectual Property or technology is commercially available to all **F1 Teams**. ~~This proprietary intellectual property shall remain the property of the Specialist Supplier.~~ The principal parameters ~~and Concept Design~~ of such components must in any case be determined by the **F1 Team** and not be available to other **F1 Teams**;
- b. Similarly, it is permitted to use commercially available sub-components or sub-assemblies in respect of **LTC**, provided these are commercially available to all **F1 Teams**. This provision applies if these components or sub-assemblies are not specifically listed as **LTC**. The FIA may request **F1 Teams** to provide a list of such sub-components and their technical specification. The FIA may classify such sub-components or sub-assemblies as **LTC** if it deems that they are being contrived to circumvent the purpose of this Article C17.

C17.3 Standard Supply Components (SSC)

- C17.3.1** “**Standard Supply Components**” (**SSC**) are components whose design and manufacture will be carried out by a supplier appointed by the FIA, to be supplied on an identical technical and commercial basis to each **F1 Team** (including, without limitation, the components identified as such in Appendix C6).
- C17.3.2** Should a selection process fail to lead to appointment of a supplier of a component classified as a **SSC**, or should the arrangement with such supplier be terminated for whatever reason, the FIA reserves the right to re-classify the **SSC** as an **LTC**, **TRC**, **DSC** or **OSC** and to introduce appropriate technical rules in the relevant Article of these Regulations in order to control the technical specification and cost of this component.
- C17.3.3** Components supplied as **SSC** must not be modified, and they must be installed and operated exactly as specified by the supplier, except for minor changes explicitly permitted in the document **FIA-F1-DOC-Cxxx**. However, each **F1 Team** is responsible for communicating directly to the relevant **SSC** supplier, while keeping the FIA informed at all times, regarding any issues of compatibility, reliability or safety in respect of an **SSC**. This may include submitting proposals for modifications to the **SSC** that an **F1 Team** considers should be made to ensure the necessary levels of safety, compatibility and reliability while at all times having due regard to cost and performance implications. In consultation with the relevant **SSC** supplier, the FIA will consider in good faith all issues raised (and modifications proposed) during the consultation process, and shall determine in its sole discretion whether or not to take any action. In exceptional circumstances, where an **F1 Team** establishes that a **SSC** is critically incompatible, unreliable or unsafe, the FIA may, at its sole discretion, authorise such **F1 Team** to carry out modifications to the **SSC** in question or use an alternative component in order to resolve the compatibility, reliability or safety issue. Permission for such a modification or usage of an alternative component will be communicated to all **F1 Teams**, and will continue to be applied until the relevant supplier introduces a new specification that resolves the reliability, compatibility or safety concern. In accordance with the severity of the reliability, compatibility or safety concern, the FIA may authorise a phased introduction of the modified **SSC**. In such cases, after consultation with **F1 Teams** and with the Supplier, the FIA will define the period of the phase-in, and any measures that need to be taken to ensure that no performance advantage (e.g., mass) is obtained by using either the old or the new specification of the **SSC**.
- C17.3.4** The use of an **SSC** is mandatory and the particular function of that **SSC** must not be by-passed, replaced, duplicated or complemented by another component. This provision also applies to any **TCC**. In exceptional circumstances, the FIA, at its sole discretion may authorise the use of alternative components.
- C17.3.5** No **F1 Team** may, either directly or via a third party pass any information (including but not limited to data, know how, operating procedures, properties and calibrations) or methodology (including but not limited to simulation software, analysis tools, etc.) which can be used to enhance the performance of a **SSC** to another **F1 Team**, or receive any such methodology from another **F1 Team**.

C17.4 Transferable Components (TRC) and Free Supply Components (FSC)

C17.4.1 “**Transferable Components**” (**TRC**) and “**Free Supply Components**” (**FSC**) are components whose design, manufacture and Intellectual Property ~~resides within~~ is owned and/or controlled by a single **F1 Team within Formula One** (the **Supplying Team**), or by a third party, but can be supplied to another **F1 Team** (the **Customer Team**) including, without limitation, the components identified as such in Appendix C6.

Free Supply Components (FSC) will follow identical technical regulation requirements to **TRC**, as outlined in this Article C17.4. However, their treatment under Section Section D [Financial] of the Regulations will be different.

C17.4.2 The provisions of this Article C17.4 regard the supply of such **TRC** or **FSC** components by a **Supplying Team** or a third party to a **Customer Team**. In the event a component classified as **TRC** or **FSC** does not get supplied to any **Customer Team**, the rules governing such a component will be identical to the rules governing **LTC**'s ~~except that Article C17.4.5 will still apply in place of Article C17.2.2~~. Furthermore, with regard to any component classed as **TRC** or **FSC**, any two teams who are not operating in a **Supplying Team – Customer Team** relationship with regard to the specific component must observe all the rules that govern **LTC**s.

C17.4.3 The **Supplying Team** ~~(or its agent)~~ must own and/or control all rights, information and/or data of any nature (including all aspects of the design, manufacturing, know-how, operating procedures, properties and calibrations) in respect of **TRC** or **FSC**, but it may supply such **TRC** or **FSC** to other **F1 Teams**.

C17.4.4 The components supplied as **TRC** or **FSC** by a **Supplying Team** to a **Customer Team** must be components identical to those used by the **Supplying Team** in the same Championship or a previous one. Under no circumstances is it permitted for the **Supplying Team** to carry out the design or manufacture of bespoke **TRCs** or **FSCs** for the specific use by a **Customer Team**. The **Customer Team** may however elect to replace or modify sub components of a **TRC** or **FSC**, but in that case all the related additional work (including, but not limited to Research and Development, simulations, design, manufacture etc.) must be carried out by the **Customer Team** or its agents. In exceptional circumstances, and with the prior approval of the FIA, the **Supplying Team** may provide assistance to the **Customer Team** for the resolution of reliability or safety issues regarding the **TRC** or **FSC**.

C17.4.5 The **Supplying Team** may **Outsource** the ~~Concept-Design, Engineering design (intended for this Article as any R&D, Engineering and CAD design) and/or manufacture~~ **Manufacturing** of any **TRC** or **FSC** to a third party ~~(including, for the avoidance of doubt, an Associate of such F1 Team)~~ provided that:

- a. the third party to whom ~~manufacture~~ the **Concept Design, Engineering, or Manufacturing** of the **TRC** or **FSC** is Outsourced may not be another **F1 Team** or a **Related Party to another F1 Team**; ~~and~~
- b. the third party, ~~excluding Specialist Suppliers~~, to whom ~~design~~ the **Concept Design or Engineering** of the **TRC** or **FSC** is **Outsourced** ~~may not be another F1 Team, or a party that directly or indirectly designs TRCs, FSC, or LTCs for any other F1 Team~~ does not directly or indirectly carry out, for another **F1 Team**, the **Concept Design, Engineering, or**

Manufacturing of an **LTC**, **TRC** or **FSC** that is in the same Group in Table 2 of Appendix C6 as the component in question;

- c. the **Specialist Supplier** to whom the **Concept Design, Engineering** or **Manufacturing of TRCs** or **FSCs** is **Outsourced** only provides these services for components for which the **Specialist Supplier** is approved; and
- d. the **F1 Team** declares to the **FIA**, all **Concept Design** or **Engineering** carried out on **TRCs** or **FSCs** by a third party.

C17.4.6 The **Supplying Team** ~~(or its agents)~~ must have exclusive ownership of and/or control over any and all rights, information or data of any nature (including but not limited to all aspects of the design, manufacturing, know-how, operating procedures, properties and calibrations) in respect of the **TRC** or **FSC** in its **Formula One cars**. However, notwithstanding the foregoing:

- a. the use of specialist Intellectual Property or technology ~~of third parties~~ belonging to a **Specialist Supplier** is permitted in respect of **TRC** or **FSC**, provided that this Intellectual Property or technology is commercially available to all **F1 Teams**. **This proprietary intellectual property shall remain the property of the Specialist Supplier.** The principal parameters of such components must in any case be determined by the **F1 Team** and not be available to other **F1 Teams**.
- b. similarly, it is permitted to use commercially available sub-components or sub-assemblies in respect of **TRC** or **FSC**, provided these are commercially available to all **F1 Teams**.

C17.4.7 A third party unrelated to any **F1 Team** may supply a **TRC** or **FSC** to a **Customer Team**, provided that it also offers to supply the **TRC** or **FSC** to any other **Customer Team** on similar commercial terms.

C17.4.8 In respect of the conditions at Article C17.2.4, any information on **TRC** or **FSC** passed on or received by an **F1 Team** or any consultancy or any other kind of services involving an **F1 Team** in relation to **TRC** or **FSC** shall be strictly limited to the designs or drawings necessary for the integration of the **TRC** or **FSC** into the design of the car and/or the data of the **TRC** or **FSC** necessary for the correct operation of the **TRC** or **FSC** on the car. For the avoidance of doubt, the following passage of information is strictly prohibited:

- a. Information specific to a particular circuit or **Race** (e.g. suspension setup information)
- b. Software or methodology for the optimisation of the performance of a **TRC** or **FSC** (e.g. simulation software)

C17.4.9 In respect of the compliance by the **Customer Team** with Section D [Financial] of the Regulations, the **Supplying Team** is mandated to provide the **Customer Team** all financial information that may be necessary to allow the **Customer Team** to demonstrate compliance with all FIA Regulations in force.

C17.5 Open Source Components (OSC and OSCNT)

C17.5.1 **Open Source Components (OSC)** and **Not Transferable Open Source Components (OSCNT)** are components whose Design Specification and Intellectual Property is made available to all **F1 Teams** through the mechanisms defined in this Article ~~C17.6~~ **C17.5** (including, without limitation, the components identified as such in Appendix C6).

- C17.5.2** For all **OSC** and **OSCNT** in use by all **F1 Teams**, the Design Specification must reside on a designated server specified by the FIA, and be accessible by all **F1 Teams**. Details about the server, access credentials and file naming and format conventions may be found in the document **FIA-F1-DOC-C039**.
- C17.5.3** Any **F1 Team** who designs a new **OSC** or **OSCNT**, or modifies the Design Specification of a previous **OSC** or **OSCNT**, must upload the new Design Specification to the designated server as specified in the document **FIA-F1-DOC-C039**.
- C17.5.4** Any **F1 Team** who creates a new, or modifies an existing, Design Specification of an **OSC** or **OSCNT** or any **OSC** or **OSCNT** manufactured to a Design Specification grants an irrevocable, royalty-free, non-exclusive, worldwide licence to all other **F1 Teams** to use and modify any of its Intellectual Property subsisting in such **OSCs** or **OSCNTs** or Design Specifications to the extent contemplated by these Regulations.
- C17.5.5** Any **F1 Team** wishing to access the server referred to in Article ~~C17.6.3~~ **C17.5.3**, or to exercise its rights under the licence described in Article ~~C17.6.4~~ **C17.5.4**, may only do so if it has agreed to be bound by the terms and conditions applicable to the FIA's designated server, by accepting the FIA Open Source Component Licence ("FOSCL"), as provided by the FIA from time to time.
- C17.5.6** In the event the **OSC** or **OSCNT** or the Design Specification of any **OSC** or **OSCNT** contains proprietary information and/or Intellectual Property of a third party supplier, this must be made clear by the **F1 Team** when uploading the Design Specification of the **OSC** or **OSCNT**, and use of the uploaded Design Specification (and any **OSC** or **OSCNT** manufactured to that Design Specification) by any other **F1 Team** exercising its rights in accordance with these Regulations must be approved in writing by the third party supplier, with a copy of such approval to be available to the FIA on request. Should it become necessary to remove any sensitive information, then the uploaded Design Specification must:
- Contain a clear reference to the supplier in question.
 - Contain sufficient information for another **F1 Team** to be able to order an identical component from the supplier.
 - Contain all the necessary information to permit another **F1 Team** to install the **OSC** or **OSCNT** in their own car.
- C17.5.7** All **F1 Teams** are obliged to declare to the FIA the version of each **OSC** or **OSCNT** that gets used on their car. This information will be made available to all **F1 Teams**.
- C17.5.8** The complete responsibility for the installation and operation of an **OSC** or **OSCNT** (including any matters related to its function, performance, reliability, compatibility or safety) resides with the **F1 Team** who uses this version of the **OSC** or **OSCNT**. Notwithstanding this provision, any **F1 Team** who encounters a functionality, reliability, compatibility or safety issue with a particular version of an **OSC** or **OSCNT** is obliged to provide such information to the FIA and all other **F1 Teams** via the designated server.

- C17.5.9** **OSCs** may be provided from one **F1 Team** to another, provided that the specification supplied from the **Supplying Team** to the **Customer Team** is of the same specification utilized by the **Supplying Team**. In such cases, their supply should be governed by all the provisions detailed in Article ~~C17.5~~ **C17.4** for **TRCs**, however none of these restrictions shall prevent an **F1 Team** from fulfilling their obligations with respect to **OSC** as required by Article ~~C17.6~~ **C17.5**.
- C17.5.10** **OSCNTs** may not be provided to any **F1 Team** by another, either directly, or through a third party.
- C17.5.11** For any year (N) where a component is designated as **OSC** or **OSCNT** for the first time, **F1 Teams** in the preceding year (N-1) must upload the design of the equivalent component in use during that preceding Championship (N-1), no later than 15 July of that year (N-1), regardless of the suitability of this component to the Regulations of the following year (N).
- C17.5.12** No **F1 Team** may, either directly or via a third party pass any information (including but not limited to data, know how, operating procedures, properties and calibrations) or methodology (including but not limited to simulation software, analysis tools, etc.) which can be used to enhance the performance of an **OSC** or **OSCNT** to another **F1 Team**, or receive any such information or methodology from another **F1 Team**.
- C17.6** **Defined Specification Components (DSC)**
- Further information concerning implementation is given in the document **FIA-F1-DOC-C039**.
- C17.6.1** **Defined Specification Components (DSC)** are components produced to a technical specification defined by the FIA.
- A **DSC** must be approved by the FIA, who will ensure compliance with the technical specification and with Article ~~C17.7~~ **C17.6**. Once approved, details of the component will be added to a Technical List contained in the document **FIA-F1-DOC-C039**.
- C17.6.2** The use of a **DSC** is mandatory and is limited to components on the relevant Technical List. The particular function of that **DSC** must not be by-passed, replaced, duplicated or complemented by another component. This provision also applies to any **TCC**. In exceptional circumstances, the FIA, at its sole discretion may authorise the use of alternative components.
- C17.6.3** Any supplier of a **DSC** must treat all the **F1 Teams** that they supply on an equitable basis.
- C17.6.4** The technical specification of a **DSC** (to its required level of detail) will be defined by the FIA and communicated to all **F1 Teams** via relevant documents in the Annexe to this Article. Changes to the specification will only be made under exceptional circumstances. Should a change become necessary, the details and timescale of the change will be decided after consultation with all interested parties.
- C17.6.5** A supplier that would like to supply a **DSC** for year (N) must provide the FIA with a full dossier containing complete technical description and commercial terms for the **DSC** before the date given in the Technical Specification. The FIA will examine the dossier in consultation with the **F1 Teams** and decide, within 30 days of its receipt, whether to add the **DSC** component in question to the list of approved DSCs, which will be set out in the Annexe to this Article.

- C17.6.6** The number of variants that an approved **DSC** supplier may supply will be defined in the technical specification of the **DSC**. Each variant of the **DSC** must be made available by the supplier to all **F1 Teams** on identical commercial terms. With the exception of changes to the technical specification and design of the **DSC** that are necessary for reliability or cost reasons, the period that the technical specification and design of the **DSC** must remain unchanged will be defined in the technical specification of the **DSC**. Any subsequent changes must follow the approval process and timescales described in Article ~~C17.7.4~~ **C17.6.4**. Changes to the technical specification or design that are necessary for reliability or cost reasons are subject to the prior approval of the FIA and must be communicated to all **F1 Teams**.
- C17.6.7** An **F1 Team** must not, either directly or indirectly via a third party or otherwise pass to another **F1 Team** any information (including but not limited to data, know how, operating procedures, properties and calibrations) or methodology (including but not limited to simulation software, analysis tools, etc.) that could be used by another **F1 Team** to enhance the performance of a **DSC**, or receive any such information or methodology from another **F1 Team**.
- C17.6.8** Should a selection process fail to approve sufficient suppliers to cover the requirements of all **F1 Teams**, the FIA reserves the right to re-classify the **DSC** as an **LTC**, **TRC**, **OSCNT**, or **OSC** and to introduce appropriate technical rules in the relevant Article of these Regulations in order to control the technical specification and cost of this component.

C17.7 List of LTC, SSC, TRC, OSC, OSCNT, and DSC

A complete list of the parts' classification, as well as a definition of the perimeter of each assembly can be found in Appendix C6.

Components which are part of an assembly will assume the classification status of that assembly unless otherwise specified.

ARTICLE C18: POWER UNIT COMPONENTS' CLASSIFICATION

Advisory Committee: PUAC

Governance: PU Manufacturers' Governance Agreement / WMSC

C18.1 General Principles**C18.1.1** Classification:

a. All **Power Unit** components used in **Formula One cars** shall be classified as:

- i. a **Listed Power Unit Component (LPUC)**;
- ii. a **Standard Supply Power Unit Component (SSPUC)**;
- iii. an **Open-Source Power Unit Component (OSPUC)**; or
- iv. a **Defined Specification Power Unit Component (DSPUC)**,

each as defined in Articles C18.2-C18.5 (inclusive).

b. Unless otherwise specified, or determined by the FIA, such components/equipment will be classified as LPUC.

c. In cases of doubt, the FIA should be consulted and shall determine the classification of a particular PU component or piece of equipment, should that differ from the default classification mentioned in Article C18.1.1(b) above.

C18.1.2 For the purposes of the remaining provisions of this Article C18, any reference to any PU Manufacturer shall include any Associate of such PU Manufacturer; and (b) any external entity (i) working on behalf of a PU Manufacturer or (ii) working for its own purposes and subsequently providing the results of its work to a PU Manufacturer.

C18.1.3 For the purposes of the remaining provisions of this Article C18, any reference to a "component" may also refer to complete assemblies.

C18.1.4 A PU Manufacturer must not use movement of personnel (whether employee, consultant, contractor, secondee or any other type of permanent or temporary personnel) from or to another PU Manufacturer (*or an External PU Manufacturer*), either directly or indirectly via an external entity, for the purpose of circumventing the requirements of this Article C18.

C18.1.5 From time to time the FIA may request that a PU Manufacturer shares certain information in connection with this Article C18 with the FIA, but only for the following purposes: (a) so that the FIA may share such information with the other PU Manufacturers for safety reasons only, or (b) to assist the FIA in considering future amendments to the Regulations, subject in each case to the relevant PU Manufacturer receiving an appropriate undertaking of confidentiality from the FIA.

C18.1.6 Except as otherwise expressly permitted by these Regulations or by the FIA, a PU Manufacturer must not

a. directly or indirectly disclose or transfer (by any means) any Intellectual Property to another PU Manufacturer,

or

b. directly or indirectly obtain (by any means) any Intellectual Property from another PU Manufacturer.

C18.1.7 The following will constitute a breach of this Article C18:

- a. the knowledge sharing, Intellectual Property transfer/receipt, merger or joining forces of:
 - i. two (or more) PU Manufacturers,
 - or
 - ii. one or more PU Manufacturers and one or more External PU Manufacturers,
- or
- b. the acquisition by one PU Manufacturer of part or whole of the company of another PU Manufacturer (or an External PU Manufacturer),
- or
- c. two PU Manufacturers entering into a services or other arrangement to support the other in delivering all or part of its supply.

In the event that a PU Manufacturer is unable to continue its participation in Formula 1 for any reason, the Intellectual Property, components or business of that External PU Manufacturer must not be acquired in part or in whole by a PU Manufacturer including by way of the External PU Manufacturer entering into an agreement to provide manufacturing or other support to the PU Manufacturer.

The FIA may, at its sole discretion, take any measures it considers appropriate in order to ensure that no PU Manufacturer obtains an unfair advantage from such an eventuality.

C18.1.8 Where a PU Manufacturer is made responsible under these Regulations for raising or reporting any issues of safety, incompatibility and/or reliability of a component that it uses on its **Power Units**, it shall not make any claim against any other party that is inconsistent with that responsibility.

C18.1.9 PU Manufacturers must not share any test facilities or equipment with another PU Manufacturer unless such facilities or equipment are commercially available to all PU Manufacturers. If PU Manufacturers are using commercially available facilities or equipment they must put in place relevant processes to ensure there is no transfer of Intellectual Property or knowledge through common personnel (or otherwise) leading to the performance enhancement of an LPUC (contrary to Article C18.2.3), or an OSPUC (contrary to Article C18.4.11), or a DSPUC (contrary to Article C18.5.7).

All PU Manufacturer' Intellectual Property (including any data) available through shared facilities or equipment shall only be available to the PU Manufacturer requesting such access to the test facilities or equipment and shall fully and exclusively remain its property.

C18.1.10 This Article C18 and these Regulations shall not restrict the normal business as usual including but not limited to mergers or acquisitions by Associates of PU Manufacturers, or investments, that are not relevant to Formula 1.

C18.2 Listed Power Unit Components (LPUC)

C18.2.1 “**Listed Power Unit Components**” (“**LPUC**”) are PU components whose design, manufacture and Intellectual Property is owned and/or controlled by a single PU Manufacturer or its agents on an exclusive basis (including, without limitation, the PU components identified as such in Appendix C4).

- C18.2.2** A PU Manufacturer must only use LPUC in its PUs that it has designed (including, for the avoidance of doubt, its three-dimensional shape and the evolution history leading to it, any preliminary designs, simulations, dynamometer tests, and analysis) and manufactured itself. However, this does not prevent the PU Manufacturer Outsourcing any R&D, engineering and/or CAD design and/or the manufacture of any LPUC to a third party (including, for the avoidance of doubt, an Associate of such PU Manufacturer) provided that:
- the PU Manufacturer retains the exclusive right to use the LPUC in Formula One for so long as it participates in Formula One;
 - the third party to whom design and/or manufacture of the LPUC is Outsourced must not be another PU Manufacturer or an Associate of another PU Manufacturer; and
 - In the case the third party to whom design and/or manufacture of the LPUC is Outsourced is not another PU Manufacturer or an Associate the provisions of Article C18.2.5 apply.
- C18.2.3** A PU Manufacturer must not, either directly or indirectly via a third party or otherwise:
- pass on any information in respect of its LPUC (including but not limited to data, designs, drawings, or any other Intellectual Property) to another PU Manufacturer or receive any information from another PU Manufacturer in respect of that PU Manufacturer's LPUC; or
 - receive consultancy or any other kind of services from another PU Manufacturer in relation to LPUC, or supply any such services to another PU Manufacturer; or
 - pass on any methodology that could be used by another PU Manufacturer to enhance the performance of LPUC (including but not limited to simulation software, analysis tools, etc.) to another PU Manufacturer, or receive any such methodology from another PU Manufacturer.
- C18.2.4** In determining whether and to what extent a PU Manufacturer is to be held liable for a breach of Article C18.2.3 that has occurred via a third party, the FIA may take into account amongst other things the extent to which the PU Manufacturer: (i) took steps to prevent the breach in question; and (ii) took steps to remedy and negate the consequences of the breach immediately upon becoming aware of the breach.
- C18.2.5** A PU Manufacturer (or its agents) must have exclusive ownership of (or the PU Manufacturer must have the exclusive right to use in the Championship) any and all rights, information or data of any nature (including but not limited to all aspects of the design, manufacturing, know-how, operating procedures, properties and calibrations) in respect of the LPUC in its PUs. However, notwithstanding the foregoing:
- The use of specialist Intellectual Property or technology of third parties is permitted in respect of LPUC, provided that this Intellectual Property or technology is commercially available to all PU Manufacturers. The detailed specifications of such LPUC must in any case be determined by the PU Manufacturer and must not be available to other PU Manufacturers;
 - Similarly, the use of commercially available sub-components or sub-assemblies in respect of LPUC is permitted, provided such sub-components or sub-assemblies are commercially available to all PU Manufacturers and are not specifically listed as LPUC. The FIA may request PU Manufacturers to provide a list of such sub-components and/or sub-assemblies and their technical specification. The FIA may classify such sub-components or sub-assemblies as

LPUC if it deems, in its sole discretion, that they are being contrived to circumvent the purpose of this Article C18.

- c. Similarly, the use of services from a third-party supplier which assist the PU Manufacturer in the design or development of its LPUCs is permitted, provided such services are commercially available to all PU Manufacturers on similar commercial terms. When two or more PU Manufacturers use the services from a given third-party supplier, full details must be made available to the FIA to demonstrate that such activity does not constitute a means to transfer, directly or indirectly, information from one PU Manufacturer to another. The services covered by this Article include but are not limited to: the use of test facilities, and the use of software.

C18.3 Standard Supply Power Unit Components (SSPUC)

C18.3.1 “**Standard Supply Power Unit Components**” (“**SSPUC**”) are **PU** components whose design and manufacture will be carried out by a supplier appointed by the FIA, to be supplied on an identical technical and commercial basis to each **PU Manufacturer** (including, without limitation, the PU components identified as such in Appendix C4).

C18.3.2 In certain cases, determined by the FIA in its sole discretion, more than one configuration of an **SSPUC** may be made available by the appointed supplier, in order to address installation differences between different PUs. In such a case, the FIA will require that any differences between the available configurations are kept to a minimum by the supplier.

C18.3.3 Should the FIA’s selection process fail to lead to the appointment of a supplier of a PU component classified as an **SSPUC**, or should the arrangement with such supplier be terminated for whatever reason, the FIA reserves the right to re-classify the SSPUC as an LPUC, OSPUC or DSPUC and to introduce appropriate technical rules in the relevant Article of these Regulations in order to control the technical specification and cost of this such PU component.

C18.3.4 PU components supplied as SSPUC must not be modified, and they must be installed and operated exactly as specified by the supplier, except for minor changes explicitly permitted in the document **FIA-F1-DOC-Cxxx**. However, each PU Manufacturer is responsible for directly and promptly informing both the FIA and the relevant SSPUC supplier, of any issues of compatibility, reliability or safety in respect of a SSPUC. This may include submitting proposals for modifications to the SSPUC that a PU Manufacturer considers should be made to ensure the necessary levels of safety, compatibility and reliability while at all times having due regard to cost and performance implications. In consultation with the relevant SSPUC supplier, the FIA will consider in good faith all issues raised (and modifications proposed) during the consultation process and shall determine in its sole discretion whether or not to take any action. In exceptional circumstances, where a PU Manufacturer establishes that a SSPUC is critically incompatible, unreliable or unsafe, the FIA may, at its sole discretion, authorise such PU Manufacturer to carry out modifications to the SSPUC in question or use an alternative PU component in order to resolve the compatibility, reliability or safety issue. Permission for such a modification or usage of an alternative PU component will be communicated by the FIA to all PU Manufacturers, and will continue to apply until the relevant supplier introduces a new specification that resolves the reliability, compatibility or safety issue.

- C18.3.5** The use of an SSPUC is mandatory and the particular function of that SSPUC must not be by-passed, replaced, duplicated or complemented by another PU component. This provision also applies to any **TCC**. In exceptional circumstances, the FIA may, at its sole discretion may authorise the use of alternative PU components.
- C18.3.6** A PU Manufacturer must not, either directly or indirectly via a third party or otherwise pass to another PU Manufacturer, any information (including but not limited to data, know how, operating procedures, properties and calibrations) or methodology (including but not limited to simulation software, analysis tools, etc.) that could which can be used by another PU Manufacturer to enhance the performance of a SSPUC to another PU Manufacturer, or receive any such information or methodology from another PU Manufacturer.
- C18.4 Open-Source Power Unit Components (OSPUC)**
- C18.4.1** “**Open-Source Power Unit Components**” (OSPUC) are PU components whose Design Specification and Intellectual Property is made available to all PU Manufacturers through the mechanisms defined in this Article C18.4 (including, without limitation, the PU components identified as such in Appendix C4).
- C18.4.2** For all OSPUC in use by all PU Manufacturers, the Design Specification must reside on a designated server specified by the FIA and be accessible by all PU Manufacturers. Details of the server, access credentials and file naming and format conventions may be found in the document **FIA-F1-DOC-Cxxx**.
- C18.4.3** Any PU Manufacturer who designs a new OSPUC or modifies the Design Specification of a previous OSPUC must upload the new Design Specification to the designated server as specified in the document **FIA-F1-DOC-Cxxx**.
- C18.4.4** Any PU Manufacturer who creates a new, or modifies an existing, Design Specification of an OSPUC or who manufactures any OSPUC manufactured to a Design Specification must grant an irrevocable, royalty-free, non-exclusive, worldwide licence to all other PU Manufacturers to use and modify any of its Intellectual Property subsisting in such OSPUC s or Design Specifications to the extent contemplated by these Regulations.
- C18.4.5** Any PU Manufacturer wishing to access the designated server referred to in Article C18.4.3, or to exercise its rights under the licence described in Article C18.4.4, may only do so if it has agreed to be bound by the terms of the terms and conditions applicable to the FIA's designated server, by accepting the FIA Open-Source **Power Unit** Component Licence (“FOSPUC L”), as provided by the FIA from time to time.
- C18.4.6** In the event the OSPUC or the Design Specification of any OSPUC contains proprietary information and/or Intellectual Property of a third-party supplier, this must be made clear by the PU Manufacturer when uploading the Design Specification of the OSPUC to the designated server. Use of the uploaded Design Specification (and any OSPUC manufactured to that Design Specification) by any other PU Manufacturer exercising its rights in accordance with these Regulations must be approved in writing by the third-party supplier, with a copy of such approval to be made available by the PU Manufacturer to the FIA on request. Should it become necessary for a PU Manufacturer to remove any confidential or commercially sensitive information from the Design Specification prior to its upload on the designated server, then the uploaded Design Specification must nevertheless contain:

- a. Contain a clear reference to the third-party supplier in question.
- b. Contain sufficient information to enable another PU Manufacturer to order an identical OSPUC from the third-party supplier.
- c. Contain all the necessary information to permit another PU Manufacturer to install the OSPUC in its own PU.

C18.4.7 All PU Manufacturers are obliged to declare to the FIA the version of each OSPUC that gets used in their PU. This information will be made available by the FIA to all PU Manufacturers.

C18.4.8 The complete responsibility for the installation and operation of an OSPUC (including any matters related to its function, performance, reliability, compatibility or safety) resides with the PU Manufacturer who uses this version of the OSPUC. Notwithstanding this provision, any PU Manufacturer who encounters a functionality, reliability, compatibility or safety issue with a particular version of an OSPUC must promptly disclose that issue to the FIA and all other PU Manufacturers via the designated server.

C18.4.9 For any year (N) where a PU component is designated as OSPUC for the first time, PU Manufacturers in the preceding year (N-1) must upload to the designated server the design of the equivalent PU component in use during that preceding Championship (N-1), no later than 15 July of that year (N-1), regardless of the suitability of that PU component to the Regulations of the following year (N).

C18.4.10 PU Manufacturers supplying **Power Units** for the 2022 Championship must upload to the designated server the design of the equivalent OSPUC component in use during that Championship, no later than 31 December 2022, regardless of the suitability of that PU component to the 2026 Regulations.

C18.4.11 A PU Manufacturer must not, either directly or indirectly via a third party or otherwise pass to another PU Manufacturer any information (including but not limited to data, know how, operating procedures, properties and calibrations) or methodology (including but not limited to simulation software, analysis tools, etc.) that could be used to by another PU Manufacturer enhance the performance of an OSPUC, or receive any such information or methodology from another PU Manufacturer.

C18.5 Defined Specification Power Unit Components (DSPUC)

C18.5.1 “**Defined Specification Power Unit Components**” (DSPUC) are PU components whose overall technical specification is defined by the FIA, which can be either (a) manufactured by the PU Manufacturer; or (b) supplied to the PU Manufacturer by one or more third party suppliers, who own and control the design, manufacture, and Intellectual Property of the PU components they supply (including, without limitation, the PU components identified as such in Appendix C4).

C18.5.2 A PU Manufacturer may be the supplier of a DSPUC, provided there is compliance by that PU Manufacturer with all of the provisions of this Article C18.5 are respected and the DSPUC in question is made available to all other PU Manufacturers on an equitable basis.

- C18.5.3** The technical specification of a DSPUC (to its required level of detail) will be defined by the FIA and communicated to all PU Manufacturers via relevant documents in the document **FIA-F1-DOC-Cxxx**. Changes to the specification for year (N) will be defined by the FIA before 1 January of year (N-2) and will require the consent of the FIA and at least 50% of the PU Manufacturers registered to compete in year (N). Changes to the specification after that date and before 1 January of year (N-1) will need the consent of the FIA and at least 75% of the PU Manufacturers registered to compete in year (N).
- C18.5.4** A third-party supplier that would like to supply a DSPUC for year (N) must provide the FIA with a full dossier containing complete technical description and commercial terms for the DSPUC before 30 June of year (N-2). The commercial terms must include any formulas for the adjustment of the supply price as a function of quantity ordered by a PU Manufacturer, or external parameters, such as inflation, material cost, etc. The supplier of the DSPUC may decide to lower the supply price at any time. The FIA will examine the dossier in consultation with the PU Manufacturers and decide, within 30 days of its receipt, whether to add the DSPUC component in question to the list of approved DSPUCs, which will be set out in the document **FIA-F1-DOC-Cxxx**.
- C18.5.5** An approved DSPUC supplier may make only one technical specification and design of a DSPUC. Such technical specification and design must be made available by the supplier to all PU Manufacturers on identical commercial terms. With the exception of changes to the technical specification and design of the DSPUC that are necessary for reliability or cost reasons, the technical specification and design of the DSPUC must remain unchanged for at least three complete calendar years. Any subsequent changes must follow the approval process and timescales described in Article C18.5.4. Changes to the technical specification or design that are necessary for reliability or cost reasons are subject to the prior approval of the FIA and must be communicated to all PU Manufacturers.
- C18.5.6** The DSPUC used by a PU Manufacturer must remain unchanged **during the homologation period for at least two complete calendar years**. During that period, a change of supplier for that DSPUC will only be permissible in the event of significant reliability issues and is subject to prior approval by the FIA.
- C18.5.7** A PU Manufacturer must not, either directly or indirectly via a third party or otherwise pass to another PU Manufacturer any information (including but not limited to data, know how, operating procedures, properties and calibrations) or methodology (including but not limited to simulation software, analysis tools, etc.) that could be used by another PU Manufacturer to enhance the performance of a DSPUC, or receive any such information or methodology from another PU Manufacturer.

C18.6 List of LPUC, SSPUC, OSPUC and DSPUC

A complete list of the PU components' classification, as well as a definition of the perimeter of each assembly can be found in Appendix C4.

PU components that are part of an assembly will assume the classification status of that assembly unless otherwise specified.

APPENDIX C1: DEFINITIONS

The definitions of this Appendix apply to all the Sections of the Regulations, unless specifically stated otherwise. Additional definitions provided either in Appendix 1 of each Section, or, for context, in the main text of the Regulations, also apply to all the Sections of the Regulations.

PART A: ~~GENERAL~~ DEFINITIONS UNDER F1 COMMISSION GOVERNANCE

Advisory Committee: TAC

Governance: F1 Commission / WMSC

“Acute Circular Cone”: is an oblique cone with a circular base in which the vertex, when projected perpendicularly onto the plane of the base, falls strictly within the circle’s boundary.

“Aerodynamic Seal”: a seal which reduces the air flow rate between two regions of differing pressures to the minimum feasible magnitude.

“Aerodynamic Surfaces”: are Bodywork surfaces which remain in contact with the **External Air Stream** after ~~any~~ all **Trim and Combination** operations have been performed, after ~~any~~ all Fillets and Edge Radii have been applied, ~~after the addition of any~~ all Bodywork defined in C3.13, and after ~~any~~ all Final Assembly described in Articles C3.12 and C3.15, but before the application of Apertures in Article C3.16.

“Car Coordinate System”: As defined in Article C2.1.1

“Car Mass”: is the mass of the car, including tyres, plus **Mass of the Driver** and **Driver Ballast** (defined in Article C4.3.2), but without fuel.

“Clutch”: The mechanical device that can connect or disconnect the **ICE** output shaft with the transmission input shaft, or transmit torque between these two shafts.

“Cockpit”: The volume that accommodates the driver.

“Cockpit Padding”: Non-structural parts placed within the **Cockpit** for the sole purpose of improving driver comfort and safety. All such material must be quickly removable.

Competition As defined in Appendix B1.

“Complete Wheel”: the assembly of **Wheel Rim**, inflated tyre, and the items permitted by Article C10.7.6. The **Complete Wheel** is considered part of the suspension.

“Concave Curvature”, “Convex Curvature”: When references are made to the curvature of Aerodynamic Surfaces, without specifying a plane of intersection, the local curvature at any point is defined as the curvature of the intersection of the surface with a plane passing through a line normal to the surface at that point. Both convex and concave radius of curvature are defined as the minimum radius, in each respective direction, that is obtained when the intersecting plane rotates 180 degrees around the normal line.

“Concept Design” means the process (or output of the process) of defining a component including; its three-dimensional shape and the evolution history leading to it, any preliminary designs, simulations, wind tunnel tests, definition of load cases for analysis.

“Control Sensor”, “Control Actuator”, “Control Loom”, “Control Unit”: A sensor, actuator, wiring loom or unit will be referred to as “Control” if it is used by any on-board strategy other than input handling, input failure detection or functions used for logging only.

It includes for example units, sensors, actuators, wiring looms used in control loops, protections or driver information.

“Curvature Continuity”: Curvature Continuity between two curves, at a given point of a curve, between two surfaces or within a surface is satisfied if the value of the curvature is continuous and in the same direction.

“Driveline Components”: The rotating components involved in transmitting torque between the **Gearbox** input shaft and the drive shafts”. This includes gears, shafts, dog rings, differential and rotating parts of the differential control mechanism. Bearings between these components and the **Gearbox Case** are included in this definition.

Edge Radius As defined in Article ~~C3.2.6~~ C3.2.7.

“Electronic Control Unit”: (“**ECU**”) A programmable embedded system that controls one or more car sub-systems.

“Electronically Controlled”: Any command system or process that utilises semi-conductor or thermionic technology.

“Engineering” means the process of preparing a **Concept Design** for manufacture and/or proving that a component is suitable for use on track. May include: stress analysis from supplied load cases, detail design, definition of laminates, preparation of drawings and ply-books, rig testing, and homologation testing

“External Air Stream”: the flow of air around the car that has a primary impact on its aerodynamic performance.

“FIA Accident Data Recorder”: (“**FIA ADR**”) An **ECU** manufactured by an FIA designated supplier to a specification determined by the FIA.

The primary purpose of the **FIA ADR** is to monitor, record or control the following:

- a. Data relevant to an accident or incident.
- b. The management of marshalling and safety systems.

“FIA Standard ECU”: An **ECU** or set of **ECUs** and their sub-components manufactured by an FIA designated supplier to a specification determined by the FIA.

The **FIA Standard ECU** comprises at least a master control unit and modules used for driver information and driver input device interfacing.

Fillet Radius As defined in Article C3.2.6.

“Formula One Car”: An automobile (the car) designed solely for speed races on circuits or closed courses that is propelled by its own means, moving by constantly taking real support on the ground, of which the propulsion and steering are under the direct control of a driver aboard the vehicle. It runs on four non-aligned **Complete Wheels**, with wheel centres that are arranged symmetrically about the plane $Y=0$, when in the straight-ahead position, to form the front and rear axles.

“Frame of Reference”: a coordinate system, geometry, component, or group of components to which stated Bodywork must remain immobile.

“Gearbox”: All the parts in the **Power Train** which transfer torque from the output shaft of the **Power Unit**, as described in Article C5.4.5, to the drive shafts (the drive shafts being defined as those components which transfer drive torque from the **Sprung Mass** to the **Unsprung Mass**). It includes all components whose primary purpose is for the transmission of power or mechanical selection of gears, bearings associated with these components (as described in Articles C9.1.2 to C9.1.4) and the casing in which they are housed (as described in Articles C9.1.5 to C9.1.7).

“Gearbox Auxiliary Components”: Components that are not included in **Driveline Components** or **Gear-Change Components** but interact directly with these components and are essential for the functioning of the **Gearbox**. This includes oil pressure and scavenge pumps, reverse-gear idler and its actuator, differential actuator, electronic sensors and actuators.

“Gearbox Case”: The structure that encloses the **Driveline Components** and **Gear-Change Components**, mounts the rear impact structure, takes suspension loads and aerodynamic loads and transfers them to the **Power Unit** through the studs defined in Article C5.4.17.

“Gear-Change Components”: Mechanical components that are involved in selecting the forward gears; barrel(s) and associated bearings, selector forks, selector rail, detent mechanisms and hydraulic actuator(s).

“Gurney”: a component that, where permitted, may be attached to the trailing edge of a profile to adjust its aerodynamic performance. In any plane perpendicular to the trailing edge, a **Gurney** must comprise of a flat section, up to 1mm thick, of a height specified in the relevant regulation, and include a bonding flange on the wing's surface. This flange may extend no more than 20mm in length and 1mm in thickness. No part of the **Gurney** shall extend beyond a line perpendicular to the surface at the profile's trailing edge.

“Header Plate”: The face of the header-tank adjacent to the **Heat Exchanger Core**, through which the **Heat Exchanger Tubes** pass and to which they are sealed.

“Heat Exchanger”: A device for transferring heat between two or more fluids.

“Heat Exchanger Core” any part of the heat exchanger where one of the fluids is divided into multiple channels, and in which the primary function of the Heat Exchanger is achieved. If two or more such components lie on the same side of the car and outboard of $Y=200$ or two or more such components are centred around the $Y=0$ plane, and have an inlet liquid from the same source, or an outlet liquid that goes to the same destination, these will be considered to be part of the same core. Such components which share neither an inlet liquid from the same source, nor an outlet liquid that goes to the same destination are considered to form separate cores, even if the individual components are integrated to each other for construction purposes.

“Heat Exchanger Fins”: devices between the **Heat Exchanger Tubes** or within the **Heat Exchanger Tubes** whose function it is to increase the level of heat exchange by convection and/or an increase of contact area.

“Heat Exchanger Tubes”: the enclosed channels within the core in which one of the fluids flows.

“Manufacturing” means the process of producing a component from a detail design. May also include the design and production of jigs, fixtures, patterns or moulds.

“Mass Damper”: A mass or system that has a degree of freedom relative to the **Sprung Mass**, which either performs no other function, or while performing another legitimate function has a compliance beyond what is necessary for its safe and reliable operation.

“Mass of the Driver”: the mass of the driver with the seat, and driving equipment, as specified in Appendix L of the **ISC** but excluding the safety harness.

“Nominal Tyre Mass”: The **Nominal Tyre Mass** is defined as the mass of a set of new, production, dry weather, tyres, rounded to the nearest 1kg and determined by the procedure defined in Article C4.7.

“Normal”: (to an Aerodynamic Surface or curve) The **Normal** at any point on an **Aerodynamic Surface** is a vector perpendicular to that point on the surface, pointing toward the local **External Air Stream**. For a curve, the **Normal** at any point is considered the same as that of the surface containing the curve.

“Open Section” and **“Closed Section”**: A section through Bodywork, from a plane of intersection, is considered closed if it forms a complete boundary on its own; otherwise, it is considered open.

Override Mode As defined in Appendix B1.

Pit Lane As defined in Appendix B1

“Primary Heat Exchanger”: a **Heat Exchanger** that uses the air flowing over or through the car to cool a fluid, which includes all of the **Heat Exchanger Core, Heat Exchanger Tubes, Header Plates, Header Tanks** and **Heat Exchanger Fins**.

“Secondary Heat Exchanger”: A **Heat Exchanger** that uses a fluid other than the air flowing over or through the car to cool another fluid.

“Simply Connected”: A surface or volume is **Simply Connected** if any closed curve lying on its surface can be **continuously** contracted to a single point (**even if intermediate expansion is required**) without leaving the surface.

Specialist Supplier has the meaning set out in Article C17.1.9

“Sprung Mass”: All parts of the car that are entirely supported by the **Sprung Suspension**.

“Sprung suspension”: The means whereby all **Complete Wheels** are suspended from the **Sprung Mass** by a spring medium.

“State of Deployment”: The **State of Deployment** is defined as starting when the adjustment of Bodywork away from its Corner Mode Position, defined by Articles C3.10.10 and C3.11.6 has been commanded by direct driver input and controlled by the FIA Standard ECU, and ending when the bodywork has returned to the same Corner Mode Position, having been disabled by the FIA Standard ECU.

“Supplying Team” means any **F1 Team** (or its **Technical Partner**) supplying **TRC, FSC, OSC, OSCNT** or **DSC**.

“Survival Cell”: The continuous closed structure containing the fuel tank, the **Cockpit** and the parts of the **Energy Store** and **MGUK**, listed in Articles C5.18 and C5.19 which lie ahead of $X_{PU}=0$.

The lower plate of the **Energy Store** assembly is considered to be part of the **Survival Cell**.

“**Swept Bounding Volume**” refers to the three-dimensional space occupied by a component as it moves through its full range of permitted positions. It is the union of all positions the component occupies, forming a continuous volume that fully encloses its motion path.

“**Tangency Continuity**” also “**Tangent Continuous**”: **Tangency Continuity** at a point on a curve or surface is achieved if the tangent value is continuous. At intersections between two curves or surfaces, **Tangency Continuity** requires that the curves or surfaces be tangent and have coinciding **Normals**.

If two adjacent surfaces are not **Tangent Continuous** but can become so by applying an **Edge Radius** of up to 1mm along their boundary, they will be considered tangent continuous at this boundary, provided such an **Edge Radius** is permitted under the relevant Articles.

Technical Partner, has the meaning set out in C17.1.11

“**Telemetry**” Wireless transmission of data from remote sources.

“**Unsprung mass**”: All parts of the car composing the **sprung suspension** external to the **sprung mass** and/or not entirely supported by the **sprung suspension**. For the purpose of this definition the boundary between sprung and **unsprung mass** will be at the suspension members’ inboard attachments.

“**Wheel Rim**”: Rim (including lips and barrel), spokes and centre hub.

PART B: DEFINITIONS APPROVED UNDER THE PROVISIONS OF THE PU GOVERNANCE AGREEMENT

Advisory Committee: PUAC

Governance: PU Manufacturers' Governance Agreement / WMSC

“Additive”: An **Additive** is a component added to the fuel at low concentration to improve a particular property of the fuel. These include (but are not limited to) antioxidants, antiknock agents, antistatic additives and deposit control additives.

“Advanced Sustainable Component” (“AS”): An **Advanced Sustainable (AS) Component** is one that is certified to have been derived from a renewable feedstock of non-biological origin (for example, a RFNBO), municipal waste, or non-food biomass. Such biomass includes, but is not limited to, lignocellulosic biomass (including sustainable forest biomass), algae, agricultural residues or waste, and dedicated non-food energy crops grown on marginal land unsuitable for food production. RFNBOs are considered renewable when the hydrogen component is produced in an electrolyser that uses new renewable electricity generation capacity. Pre-commercial plants producing RFNBOs do not need to use electricity from new renewable electricity generating capacity. **Pre-commercial plants**, producing **AS** fuel or **AS** fuel components, may use renewable energy certificates and/or low-carbon hydrogen guarantees-of-origin certificates to improve their GHG emission reduction. Biocomponents from food crops can be regarded as an advanced sustainable component only if they have already fulfilled their food purpose (e.g. waste vegetable oil because it has already been used and is no longer fit for human consumption). Furthermore, the biomass, from which the advanced sustainable component was made, must not originate from land with high biodiversity such as undisturbed primary forest or woodland, land designated for nature protection or highly biodiverse grassland, and were in this state in or after January 2008. Additionally, the biomass must not originate from any land with high-carbon stock such as wetlands and peatlands.

“Alkali Metal”: Group 1 elements, excluding hydrogen.

“Ancillary”: A component whose function is to support the primary activities of a main system to allow it to operate.

“Aromatics”: Monocyclic and bicyclic aromatic rings with or without paraffinic side chains.

“Auxiliary Oil Tank” (“AOT”): An **Auxiliary Oil Tank (AOT)** is a singular vessel connected to the engine whose sole function is to hold engine oil for the replenishment of the engine lubrication system.

“Basic insulation”: Insulation applied to **Live Parts** which provides protection against **Hazardous Electric Shock** in case of contact.

“Battery Management System” (“BMS”): The **BMS** is a set of important safety systems of the ES. The main function is as a monitoring and a charge-balancing circuit to keep all cells under normal operating conditions, within the specified parameters e.g. voltage, temperature, current, state of balance, defined by the manufacturer.

“Breakout Box”: Unit used to perform low voltage looms adaptation.

“Car Main Ground”: The electrical reference potential of all conductive parts of the car, typically located on the **ICE** block.

“Cell Tabs”: Cell connection terminals which connect the cathode and anode electrodes to the external circuit.

“Combustion chamber”: An enclosed space in the engine cylinder controlled by the opening and closing of the poppet valves in which combustion takes place.

“Compressor Inlet”: A component containing a duct of closed cross section through which all air destined for combustion enters ~~any the~~ compressor.

“Compressor Outlet”: One or more components each of them containing a duct of closed cross section through which all air destined for combustion exits the compressor.

“Control Electronics - Power Unit” (“PU-CE”): Any component used to control **Power Unit** sub-systems and containing programmable semiconductors or high-power switching devices.

It includes, but is not limited to, **MGU-K Control Unit (CU-K)**, power box, **DC-DC Unit**, power distribution board.

It excludes any **FIA Standard ECU**, FIA sensors and ES safety **Control Electronics**.

“Co-Processing”: is the procedure of processing feedstocks blended of sustainable and non-sustainable origin.

“Cylinder Head”: The **Cylinder Heads** are the components that close all the cylinders of each bank of the engine and form the structure between the **Combustion Chambers** and the camshaft bearings between at least the front of the forward cylinder bore and the rear of the rearward cylinder bore on each bank.

“Cylinder Liner”: A component installed into the crankcase whose primary function is to provide a durable surface on which the piston and piston rings run. There must be only a single **Cylinder Liner** per cylinder bore and the liner may also provide the sealing interface between the cylinder bore and the **cylinder head**.

“DC-DC Converter”: An electronic circuit or electromechanical device, only capable of consuming energy, that converts a source of direct current (DC) from one voltage level to another for use by the electrical and electronic components of the car and **Power Unit**.

“DC-DC Unit”: The unit containing the DC-DC(s) that converts from high to low voltage.

“Deck Height”: (Appendix C3, Drawing 6) The distance on each bank between the crank axis and the **Top Deck**.

“Denaturant”: in this instance is a toxic and/or unpalatable adulterant added to ethanol making it unsuitable for human consumption.

“Diolefins”: Straight chain or branched or monocyclic hydrocarbons (with five or more carbon atoms in any ring) with or without paraffinic side chains, containing two double bonds per molecule.

“Double insulation”: Insulation comprising both **Basic Insulation** and **Supplementary Insulation**. **Double insulation** is composed of two layers of insulators with two different failure modes. Those two layers can be tested separately.

“Electronic Box”: Unit that contains at least 1 microcontroller.

“Energy Recovery System” (“ERS”): A system that is designed to recover energy from the car, store that energy and make it available to propel the car and, optionally, to drive any **Ancillaries** and actuation systems necessary for its proper function.

“Energy Store” (“ES”): The part of ERS that stores energy, including its safety **Control Electronics** and a minimal housing.

“Engine” (“ICE”): The internal combustion engine including **Ancillaries** and actuator systems necessary for its proper function.

“Engine Cubic Capacity”: The volume swept in the cylinders of the engine by the movement of the pistons. This volume shall be expressed in cubic centimetres. In calculating **Engine Cubic Capacity**, the number Pi shall be 3.1416.

“Engine Exhaust System”: Assembly of parts conveying the engine exhaust fluids from the **Cylinder Head** up to but not including the turbine and/or **Wastegate**. It does not include the turbine or **Wastegate** exit tailpipe(s). A set comprises left and right assemblies.

“Engine Plenum”: A pressurised vessel upstream of the **Combustion Chamber** containing all of the air destined for combustion. This vessel (or vessels) may be comprised of several components. Pipes, as generally understood, conveying air from the compressor to the engine are not part of the **Engine Plenum**.

“ERS Auxiliary Circuit”: Any circuit inside or outside the ES and **PU-CE** elements which does not form part of the **High Voltage DC Bus** current flow path that connects the **ES** to the **CUK** and **DCDC**, and which is typically designed to monitor or to perform functionalities allowing the **ERS** to operate correctly and safely. Example of auxiliary circuits include, but are not limited to, voltage measurement circuits, insulation measurement circuits, contactor pre-charge circuits, battery (dis)charge connections, cable disconnect detection circuits.

“ERS-K”: The only part of the **ERS** allowed to propel the car. It is composed of the **MGU-K**, the **CU-K** and the **ERS-K Phase Conductors**.

“ERS-K Phase Conductors”: The components allowing electrical current to flow between the **CU-K** and the **MGU-K** windings composed of conductors (e.g. busbars, cables or wires) and respective connection interfaces not part of the **ESME** or **MGU-K**.

“ES Cell”: The elementary part of the **ES** that produces and stores electricity through electro-chemical reactions.

“ES Main Enclosure” (“ESME”): External structure that encloses at least the elements listed in Article C5.17.7 and allows their installation inside of the ERS Reference Volume (**RV-PU-ERS**). It may be composed of elements rigidly linked to form a continuous closed volume.

“Exclusivity Agreement”: An **Exclusivity Agreement** is deemed to be any agreement concluded between the supplier of such parts (including any **PU Manufacturer**) and any **PU Manufacturer**, which has the purpose and/or the effect of restricting or delaying the possibility for such a supplier:

- a. to consider any request from another **PU Manufacturer**; and/or
- b. to supply, under reasonable commercial conditions, a part meeting the applicant’s specifications.

“Exposed Conductive Part”: Conductive part of the electric equipment, which can be touched by a test finger according to IP2X and which is not normally live, but which may become live under single fault conditions.

“External PU Manufacturer”: means a person or entity (including any corporate or unincorporated body) that (directly or indirectly): (i) was registered to supply **Power Units** in the **Championship** and has withdrawn for any reason; or (ii) a power unit manufacturer that is undertaking development work to supply **Power Units** but has not yet registered with the FIA to supply for the **Championship**. This definition does not include third parties undertaking development work in accordance with these Regulations on behalf of the instructions of a **PU Manufacturer** unless that third party ceases to have a contract or other arrangement with a **PU Manufacturer**.

“Flywheel”: Inertial components connected directly to the rear of the crankshaft

“Fuel Flow Meter”: A sensor whose function is to measure the flow of the fuel passing through it.

“Fuel injector”: Any device or component that delivers fuel into an oxidiser.

“Hazardous Electric Shock”: Physiological reaction generated by an electrical current greater than 2mA passing through the human body.

“Heat Shield”: A **Heat Shield** is a component or an assembly whose primary function is to shield components from thermal radiation and is not permanently attached to another component or assembly (such as by riveting, bonding, welding, brazing, or plating).

“High Pressure Fuel Pump”: A mechanical device whose sole function is to pressurise the fuel to the pressure required for the high -pressure injection. It may be **Electronically Controlled**.

“High Voltage”: Classification of an electrical component or circuit whose **Maximum Working Voltage** is > 30 V AC rms or > 60 V DC.

“HV DC Bus”: The set of electrical conductors which are not part of the ES or any **PU-CE** and that serves as the pathway to the electrical energy directly used to propel the car flowing between those elements.

“ICE Ballast”: **ICE Ballast** is a component fixed to the **ICE** whose sole purpose is to provide a mass to adjust the final weight of the **ICE** as fitted.

“Ignition Coil”: Assembly including an induction coil that supplies the voltage to the spark plug.

“In-Cylinder Pressure Sensor”: A sensor whose function is to measure the pressure in the **Combustion Chamber**.

“Insert”: An **insert** within a PU component is a non-dismountable part whose function is solely to locally support a function of this component. **A dismountable part is fitted with no interference and can be repeatably removed and refitted without additional processes (such as pressing, machining, welding, brazing). Brackets bonded to a PU component for cable/hose retention or similar will not be considered as inserts.**

“Journal Bearing Diameter”: (Appendix C3, Drawing 7) The maximum diameter of the bearing journal across its entire width excluding fillet radii.

“Journal Bearing Width”: (Appendix C3, Drawing 7) The minimum width of the inner bearing surface at its minimum diameter. This excludes any additional bearing shell width resulting from edge chamfers, radii or any other relieving feature.

“Knock Sensor”: A sensor whose sole function is to measure the knock intensity in the **Combustion Chamber**.

“Live Part”: Conductive part which belongs to a **High Voltage** component or circuit in normal use and which has an insulation resistance lower than 100Ω/VDC and 500Ω/VAC.

“Maximum Working Voltage”: Highest value of AC peak voltage or of DC voltage that can occur under any normal operating conditions according to the manufacturer's specifications, disregarding residual variation of the DC voltage shorter than 100µs. Field weakening is considered as a normal operation, therefore a MGU with a maximum back-EMF higher than the **Maximum Working Voltage** established by this technical regulation is allowed.

“Metals”: are defined as alkali metals, alkaline earth metals, transition metals, actinides, lanthanides, post-transition metals and metalloids.

“MGU-K Control Unit” (“CU-K”): The bi-directional DC-AC power converter sat between the **ES** and the **MGU-K**. It is composed of power modules, DC-link capacitor(s), gate driver board(s), CUK logic board, and may contain other devices that perform functions related to the **CU-K** operation such as DC bus discharge circuits, sensors, Y-capacitors, housing, and cooling systems.

“MGU-K Mechanical Transmission”: The **MGU-K Mechanical Transmission** is defined as the device that provides any mechanical speed reduction between the MGU-K and a rotating part of the **ICE** specifically and only for the MGU-K. If the **MGU-K Mechanical Transmission** connects to a shaft/component on the **ICE** that is already rotating at a speed above or below crank speed for other purposes, that existing gear ratio (driving some part of the **ICE** other than the MGU-K) is not included in the MGU-K transmission. The **MGU-K Mechanical Transmission** may be wholly mounted on the **ICE** or on the MGU-K or partly on both.

“Motor Generator Unit – Kinetic” (“MGU-K”): The **Motor Generator Unit - Kinetic** is the rotating electromechanical machine that converts electrical energy into mechanical energy (a ‘motor’) and vice versa (a ‘generator’).

“Municipal Waste”: is household waste and waste similar in nature and composition to household waste. For the purposes of this article, only solid, non-toxic, non-hazardous waste material that cannot be re-used, re-covered or recycled, meeting the principles of the waste hierarchy, is considered suitable source material for AS components or AS fuel production.

“Naphthenes” Monocyclic alkanes (with five or more carbon atoms in the ring) with or without paraffinic side chains.

“Oil Tank”: The **Oil Tank** is a singular vessel directly connected to the engine oil feed at the inlet of the oil pressure pump.

“Olefins”: Straight chain and branched monoolefins and diolefins. Monocyclic monoolefins (with five or more carbon atoms in the ring) with or without paraffinic side chains.

“Oxygenates”: Organic compounds containing oxygen.

“Paraffins”: Straight chain and branched alkanes.

“Pop-off valve” A device used to release air from the engine intake air system, anywhere downstream of the compressor wheel and upstream of the intake valves, and to recirculate it upstream of the compressor wheel.

“Power Box Unit”: An electronic device used to drive the **High Pressure Fuel pump**, injection and ignition system.

“Power Train”: The **Power Unit** and associated torque transmission systems, up to but not including the drive shafts.

“Power Unit” (“PU”): The internal combustion engine and turbocharger, complete with its **Ancillaries**, the **Energy Recovery System** and all actuation systems and **PU-Control electronics** necessary to make them function at all times.

“Pre-Commercial Plant”: is one that has a total maximum production capacity of all AS products of 40,000m³ per year.

“Pressure Charging”: Increasing the weight of the charge of the fuel/air mixture in the **Combustion Chamber** (over the weight induced by normal atmospheric pressure, ram effect and dynamic effects in the intake and/or exhaust system) by any means whatsoever. The injection of fuel under pressure is not considered to be **Pressure Charging**.

“PU component”: means any component listed as “ICE”, or “EXH”, or “TC”, or “MGU-K”, or “ES”, or “PU-CE” in Table 1 of Appendix C4 under the column “PU ELEMENT (Art. 5.1.2)”.

“Reinforced Insulation”: Insulation of hazardous-live-parts which provides a degree of protection against electric shock equivalent to **Double Insulation**.

“Supplementary Insulation”: Independent insulation applied in addition to **Basic Insulation** for protection against **Hazardous Electric Shock** in the event of a failure.

“Thermal Insulation”: **Thermal insulation** is a part fitted adjacent to a component whose primary function is to reduce the heat transfer between that component and its surroundings.

“Throttle”: A variable geometry device or arrangement which restricts the airflow into the **ICE** by means of a variable area restriction within the intake. The **Throttle** may only comprise of one or more rotating butterfly valve or one or more rotating barrel valve.

“Top Deck”: (Appendix C3, Drawing 6) The single plane surface of the block, normal to the cylinder centreline coincident with the primary connection between the crankcase and the **Cylinder Head**.

“Trumpet”: A **Trumpet** is a component(s) that extends the geometrical path of air destined for combustion directly into each individual cylinder. The **Trumpet(s)** may also include any **Throttle(s)** permitted by C5.6.3.

“Turbo Charger” (“TC”): The assembly of a compressor used for **Pressure Charging** of the engine, a turbine connected to the **Engine Exhaust System** used to drive the compressor, the drive system between the compressor and the turbine and their respective housings and bearings.

“Valve Stem”: The **Valve Stem** is the part of the component that slides within the valve guide during operation.

“Wastegate”: A device used to release exhaust fluids from the complete exhaust system, anywhere downstream of the exhaust valves and upstream of the turbine wheel.

PART C: DEFINITIONS WITH SHARED APPROVAL

Advisory Committee: TAC and PUAC

Governance: F1 Commission / PU Manufacturers' Governance Agreement / WMSC

~~“Associate” means, with respect to an **F1 Team** or **PU Manufacturer** in the **Championship** (and any entity representing that **F1 Team** or **PU Manufacturer**):~~

~~a. any other person or entity (including any corporate or unincorporated body) that (directly or indirectly):~~

~~i. owns share capital or business assets of the **F1 Team** or **PU Manufacturer**; or~~

~~ii. has the power to exercise voting rights in relation to the **F1 Team** or **PU Manufacturer**; or~~

~~iii. has the power to appoint members of the supervisory board, board of directors or bodies legally representing the **F1 Team** or **PU Manufacturer**; or~~

~~iv. has the power to conduct the affairs of the **F1 Team** or **PU Manufacturer** by constitutional documents or agreement or otherwise; and~~

~~b. any other person or entity in the same legal group structure as the **F1 Team** or **PU Manufacturer** from time to time; and~~

~~c. any agent, contractor (or sub-contractor) or other person or entity (including any corporate or unincorporated body) that is set up or used by an **F1 Team** or **PU Manufacturer** to circumvent the requirements of Articles C17 or C18.~~

“Ceramic Material”: (e.g. Al₂O₃, SiC, B₄C, Ti₅Si₃, SiO₂, Si₃N₄) – These are inorganic, nonmetallic solids.

“Coating”: a covering that is applied to the surface of an object, referred to as the substrate.

“Commercially Available Material”: A material that:

a. Is available on a non-exclusive basis and under normal commercial terms to all **F1 Teams**.

b. Is not supplied to a specification tighter than the standards listed in Section C15.2 (where applicable) with a primary aim of improving the baseline mechanical properties. Additional specifications concerned with process control and/or quality control are permissible.

c. Has no restrictions or agreements in place that prevents the supplier from openly marketing it.

“Composite Materials”: These are materials where a matrix material is reinforced by either a continuous or discontinuous phase. The matrix can be metallic, ceramic, polymeric or glass based. The reinforcement can be present as long fibres (fibre length greater than 13mm) or short fibres, whiskers and particles (discontinuous reinforcement). Nanoscale reinforced materials are to be considered as composites. (a reinforcement is considered to be nanoscale if any dimension of the reinforcement is less than 100nm)

“Design Specification”: means, in respect of a component all design (including three-dimensional geometry, tolerances, materials, surface finishes and design standards), manufacturing, installation and operational information related to that component.

“Foil Metallurgy”: A process by which a material or component is made by the consolidation of metallic foils (by co-forging, welding etc.) which increases the mechanical properties of the

material with respect to those of a bulk material. For this definition, a foil is considered a material with a thickness of less than 1mm.

“Intellectual Property”: means:

- a. patents, rights to inventions, designs, copyright and related rights, database rights, trade marks and trade names, rights in get-up and related goodwill and the right to sue for passing off or unfair **competition** (in each case whether registered, registerable or unregistered);
- b. proprietary rights in domain names;
- c. rights to use, and protect the confidentiality of, trade secrets, know-how and confidential information;
- d. applications, and rights to apply for and be granted registrations, including extensions and renewals of, such rights; and
- e. all other rights of a similar nature or having an equivalent effect anywhere in the world.

“Intermetallic Materials”: (e.g., TiAl, NiAl, FeAl, Cu₃Au, NiCo) – These are materials where the material is based upon intermetallic phases, i.e. the matrix of the material consists of greater than 50%v/v intermetallic phase(s). An intermetallic phase is a solid solution between two or more metals exhibiting either partly ionic or covalent, or metallic bonding with a long-range order, in a narrow range of composition around the stoichiometric proportion.

“Metal Matrix Composites” (“MMC”): These are composite materials with a metallic matrix containing a minimum ratio of 0.5% volume/volume of other ceramic, metallic, carbon or intermetallic phase which is not soluble in the liquid phase at 100°C above the melting point of the metallic matrix.

“Metallic Materials Used for Additive Manufacture”: A group of materials in powder form used for manufacturing near-net shape components from a digital model processed in separate layers and joined by either selective melting, bonding, or sintering.

“Nanomaterials”: These are purposely created objects that have one or more dimensions (e.g., length, width, height, diameter) which is less than 100nm. (100x10⁻⁹m) as defined in ISO 80004-1:2023.

“Outsourcing” or **“Outsourced”**: means procuring or procured goods or services by contract with an external supplier.

“Polymeric Material”: any thermoplastic or thermoset material.

“Related Party” has the meaning set out in Section D: Financial Regulations (F1 Team)

“Shape Memory Material”: A material that is configured to move reversibly between two (or more) different shapes when it is subjected only to a non-mechanical uniform stimulus (thermal, electrical, magnetic, optical, etc.), or exhibits a reversible phase change when subject to an applied stress. For clarity, this does not include consequential geometric changes that result solely from the effects of thermal expansion.

“Surface Texturing”: Modification of a component surface to obtain a defined patterning to enhance the tribological performance.

“X Based Alloy”: (e.g., Ni based alloy) – X must be the most abundant element in the alloy on a %w/w basis. The minimum possible weight percent of the element X must always be greater than the maximum possible of each of the other individual elements present in the alloy.

“X–Y Based Alloy”: (e.g., Al–Cu based alloy) – X must be the most abundant element. In addition, element Y must be the second highest constituent (%w/w), after X in the alloy. The mean content of Y and all other alloying elements must be used to determine the second highest alloying element (Y).

APPENDIX C2: REGULATION VOLUMES

Advisory Committee: TAC (Unless otherwise stated)

Governance: F1 Commission / WMSC (Unless otherwise stated)

1 General Definitions

- 1.1 This Appendix defines the construction of CAD reference sections, **Reference Surfaces** and **Reference Volumes** used throughout the Regulations to assess legality in conjunction with Article C3. However numerous further usages of such definitions are used in other Articles.
- 1.2 Unless otherwise stated, only the declared reference section, **Reference Surface** or **Reference Volume** from each Article can be used to assess legality. All other geometry used during the construction of these sections, surfaces or volumes must be considered for reference purposes only.
- 1.3 In cases where an object (surface or volume) is trimmed using a surface, this must be performed by first finding the intersection between the object and the surface and then partitioning the object into two, by separating it at this intersection. One of these two parts is then discarded according to the relevant Article and the residual of the trimmed object is all that remains after the operation.
- 1.4 All volumes are implicitly symmetrical about the plane $Y=0$.
- 1.5 The prefix “RV-“ always refers to a **Reference Volume**, whereas the prefix “RS-“ refers to a **Reference Surface**.
- 1.6 The CAD models of all the volumes and surfaces listed in this Appendix are available for **F1 Teams** or PU Manufacturers to download with a standard range of parameters. The FIA will provide **F1 Teams** or PU Manufacturers with a specific model on request.
- 1.7 Should an inconsistency arise between a volume generated manually using the process outlined in this Article, or a volume that has been downloaded by the process outlined in Article 1.6 of this Appendix, the FIA will adjudicate on a case-by-case basis the volume that will be applicable and correct the one that will be judged to have an inconsistency or error.

2 Legality Volumes or Surfaces Defined by CAD Models

- 2.1 The legality volumes and surfaces listed below are defined exclusively by CAD data and are available to download from the FIA’s CAD Portal. Unless otherwise stated, the volumes must be positioned with the origin of the model at the coordinates given and with the model axes parallel to, and in the same direction as the corresponding car axes.

Volume or Surface	CAD Part No	Revision	Notes
RV-PU-ICE *	FIA-LEG-0076	C	Positioned at $[X_{PU}=0, 0, 0]$
RV-PU-OT *	FIA-LEG-0075	A	Positioned at $[X_{PU}=0, 0, 0]$
RV-PU-TC *	FIA-LEG-0077	A	Positioned at $[X_{PU}=0, 0, 0]$
RS-PU-FWD-ERS *	FIA-LEG-0101	A	Positioned at $[X_{PU}\leq -360, 0, 0]$
RS-FWD-FUEL-LIMIT	FIA-LEG-0010 FIA-LEG-0240	A B	Positioned at $[X_C=0, 0, 0]$
RV-CH-MID-MIN	FIA-LEG-0001	E	Positioned at $[X_C=0, 0, 0]$

RV-COCKPIT-ENTRY	FIA-LEG-0004	C	Positioned at $[X_C=0, 0, 0]$
RV-COCKPIT-DRIVER	FIA-LEG-0006 FIA-LEG-0242	D A	Positioned at $[X_C=0, 0, 0]$
RS-FWH-DRUM	FIA-LEG-0141	E	Positioned at $[X_W, Y_W, Z_W] = [0, 0, 0]$ (front wheel)
RS-RWH-DRUM	FIA-LEG-0190	EF	Positioned at $[X_W, Y_W, Z_W] = [0, 0, 0]$ (rear wheel)
RV-F-RIM-MIN	FIA-LEG-0138	E D	Positioned at $[X_W, Y_W, Z_W] = [0, 0, 0]$ (front wheel)
RV-R-RIM-MIN	FIA-LEG-0139	E D	Positioned at $[X_W, Y_W, Z_W] = [0, 0, 0]$ (rear wheel)
RS-F-RIM-DISC	FIA-LEG-0185	A B	Positioned at $[X_W, Y_W, Z_W] = [0, 0, 0]$ (front wheel)
RS-R-RIM-DISC	FIA-LEG-0186	A B	Positioned at $[X_W, Y_W, Z_W] = [0, 0, 0]$ (rear wheel)
RV-DIFF	FIA-LEG-0137	A	Positioned at $[X_R=0, 0, 0]$
RV-COCKPIT-HELMET	FIA-LEG-0012	B	Positioned at $[X_C=0, 0, 0]$
RS-FLOOR-WINGLET	FIA-LEG-0192	D E	Positioned at $[X_R=0, 0, 0]$
RV-FLOOR-WINGLET	FIA-LEG-0204	B C	Positioned at $[X_R=0, 0, 0]$
RV-TAIL-RIS	FIA-LEG-0168	A	Positioned at $[X_{DIF}=0, 0, 0]$
RV-FWH-LIP	FIA-LEG-0171	C	Positioned at $[X_W, Y_W, Z_W] = [0, 0, 0]$ (front wheel)
RV-RWH-LIP	FIA-LEG-0179	C	Positioned at $[X_W, Y_W, Z_W] = [0, 0, 0]$ (rear wheel)
RV-FWH-SCO	FIA-LEG-0172	B	Positioned at $[X_W, Y_W, Z_W] = [0, 0, 0]$ (front wheel)
RV-RWH-SCO	FIA-LEG-0180	A	Positioned at $[X_W, Y_W, Z_W] = [0, 0, 0]$ (rear wheel)
RV-RWH-FDEF	FIA-LEG-0181	B C	Positioned at $[X_W, Y_W, Z_W] = [0, 0, 0]$ (rear wheel)
RS-FWH-RDEF	FIA-LEG-0207	B C	Positioned at $[X_W, Y_W, Z_W] = [0, 0, 0]$ (front wheel)
RV-FWH-RDEF	FIA-LEG-0208	B C	Positioned at $[X_W, Y_W, Z_W] = [0, 0, 0]$ (front wheel)
RV-RWH-STAY	FIA-LEG-0182	B C	Positioned at $[X_W, Y_W, Z_W] = [0, 0, 0]$ (rear wheel)
RV-HALO	FIA-LEG-0237	A	Positioned at $[X_C=0, 0, 0]$
RV-LATERAL-SAFETY-LIGHT	FIA-LEG-0238	A B	Positioned at $[X_C=0, 0, 0]$
RV-SKID-FWD	FIA-LEG-0236	A	Positioned at $[X_F=500, 0, 0]$
RV-SKID	FIA-LEG-0235	A	Positioned as specified in C3.6.1

* *Advisory Committee: PUAC*
Governance: PU Manufacturers' Governance Agreement / WMSC

3 ERS Reference Volume (RV-PU-ERS)

Advisory Committee: PUAC

Governance: PU Manufacturers' Governance Agreement / WMSC

RV-PU-ERS is composed of the following elements:

- 3.1** The **Reference Surface RS-PU-FWD-ERS** must be positioned with the origin of the model at $[X_{PU} \leq -360, 0, 0]$.
- 3.2** On the plane $X_{PU} = 0$, a simple, closed polygon whose edges pass through the following $[Y, Z]$ vertices sequentially:
- a. $[0, 1], [240, 1], [280, 4.1], [280, 51], [230, 51], [230, 380], [0, 380], [0, 1]$
- 3.3** Once the surface in **§3.2** is fully defined, it must be extruded along X to $X_{PU} = -1500$.
- 3.4** Once the volume in **§3.3** is fully defined; it must be trimmed by the surface **RS-PU-FWD-ERS** with all material ahead of this surface discarded.
- 3.5** The fully defined volume in **§3.4** is “**RV-PU-ERS**”

4 Floor Body Reference Volume (RV-FLOOR-BODY)

RV-FLOOR-BODY is composed of the following elements:

- 4.1** On a plane through $Z=0$, a simple, closed polygon whose edges pass through the following $[X, Y]$ vertices sequentially:
- a. $[X_F = 350, 0], [X_F = 350, 25], [X_F = 1250, 340], [X_F = 1400, 390], [X_R = -1050, 390], [X_R = -775, 350], [X_R = -625, 300], [X_R = -475, 240], [X_R = 300, 75], [X_R = 300, 0], [X_F = 350, 0]$.
- 4.2** Once the surface in **§4.1** is fully defined, it must be extruded along Z to $Z = 275$.
- 4.3** Once the volume in **§4.2** is fully defined, it must be trimmed with a plane passing through the following three points with all material below the plane discarded.
- a. $[X_F = 1650, 250, 0], [X_F = 850, 250, 0], [X_F = 1650, 375, 10]$.
- 4.4** Once the volume in **§4.3** is fully defined, an **Edge Radius** of R200, applied to the external corner that lies on the X-Aligned axis through $[Y, Z] = [250, 0]$.
- 4.5** On a plane through $Y=0$, a section whose edges pass through the following $[X, Z]$ vertices sequentially:
- a. $[X_F = 1450, 275], [X_F = 1450, 75], [X_R = -600, 75], [X_R = -350, 175], [X_R = 300, 250]$.
- 4.6** Once the section in **§4.5** is fully defined it must be extruded along Y to $Y = 400$.
- 4.7** Once the volume in **§4.4** and the sheet in **§4.6** are fully defined, the volume must be trimmed with the sheet with all material above the sheet discarded.
- 4.8** Once the volume in **§4.7** is fully defined, it must be trimmed with a plane passing through the following three points with all material forward of the plane discarded.
- a. $[X_F = 350, 0, 275], [X_F = 425, 0, 0], [X_F = 425, 75, 0]$.
- 4.9** On a plane through $Z=50$, a simple, closed polygon whose edges pass through the following $[X, Y]$ vertices sequentially:

- a. $[X_F = 1100, 0]$, $[X_F = 1100, 770]$, $[X_R = -335, 700]$, $[X_R = -335, 400]$, $[X_R = -150, 365]$, $[X_R = 300, 365]$, $[X_R = 300, 0]$, $[X_F = 1100, 0]$.
- 4.10** Once the surface in §4.9 is fully defined, it must be extruded along Z to Z = 250.
- 4.11** On a plane through Y=0, a section whose edges pass through the following [X, Z] vertices sequentially:
- a. $[X_F = 1100, 175]$, $[X_F = 1775, 75]$, $[X_R = -600, 75]$, $[X_R = -350, 175]$, $[X_R = 300, 250]$, $[X_R = 350, 250]$.
- 4.12** Once the section in §4.11 is fully defined, it must be extruded along Y to Y = 770.
- 4.13** Once the volume in §4.10 and the sheet in §4.12 are fully defined, the volume must be trimmed with the sheet with all material above the sheet discarded.
- 4.14** On a plane through $X_F = 930$, a section whose edges pass through the following [Y, Z] vertices sequentially:
- a. $[350, 175]$, $[650, 125]$, $[770, 75]$.
- 4.15** Once the section in §4.14 is fully defined, it must be extruded along X to $X_F = 1775$.
- 4.16** Once the volume in §4.13 and the sheet in §4.15 are fully defined, the volume must be trimmed with the sheet with all material above the sheet discarded.
- 4.17** An axis-aligned cuboid, which has one interior diagonal defined by the points:
- a. $[X_R = -600, 400, 65 75]$, $[X_R = -335, 760, 250]$.
- 4.18** Once the volume in §4.17 is fully defined, it must be trimmed with a plane passing through the following three points with all material inboard of the plane discarded.
- a. $[X_R = -600, 550, 65 75]$, $[X_R = -335, 400, 65 75]$, $[X_R = -335, 400, 250]$.
- 4.19** Once the volume in §4.18 is fully defined, it must be subtracted from the volume defined in §4.16 to leave one unified volume.
- 4.20** On a plane through Y=0, a simple, closed polygon whose edges pass through the following $[X_R, Z]$ vertices sequentially:
- a. $[-525, 50]$, $[300, 165]$, $[300, 50]$, $[-525, 50]$.
- 4.21** Once the surface in §4.20 is fully defined, it must be extruded along Y to Y = 345.
- 4.22** An axis-aligned cuboid, which has one interior diagonal defined by the points:
- a. $[X_R = -325, 345, 50]$, $[X_R = 300, 400, 100]$.
- 4.23** Once the volumes in §4.21 and §4.22 are fully defined, they must be subtracted from the volume defined in §4.19 to leave one unified volume.
- 4.24** Once the volumes in §4.8 and §4.23 are fully defined, they must be united to create a single unified volume.

The fully defined volume in §4.24 is “RV-FLOOR-BODY”.

5 Floor Sidewall Reference Volume (RV-FLOOR-SIDEWALL)

RV-FLOOR-SIDEWALL is composed of the following elements:

5.1 On a plane through $Z = 35$, a simple, closed polygon whose edges pass through the following $[X_R, Y]$ vertices sequentially:

- a. $[-335, 400]$, $[-150, 365]$, $[350, 365]$, $[350, 345]$, $[-335, 345]$, $[-335, 400]$.

5.2 Once the surface in §5.1 is fully defined, it must be extruded along Z to $Z = 275$.

5.3 Once the volume in §5.2 is fully defined, it must be trimmed with the sheet from §4.12 with all material above the sheet discarded.

The fully defined volume in §5.3 is “**RV-FLOOR-SIDEWALL**”.

6 Floor Foot Reference Volume (RV-FLOOR-FOOT)

RV-FLOOR-FOOT is composed of the following elements:

6.1 On a plane through $Z = 50$, a simple, closed polygon whose edges pass through the following $[X_F, Y]$ vertices sequentially:

- a. $[650, 650]$, $[650, 890]$, $[825, 890]$, $[1350, 760]$, $[1350, 625]$, $[650, 650]$.

6.2 Once the surface in §6.1 is fully defined, it must be extruded along Z to $Z = 100$.

The fully defined volume in §6.2 is “**RV-FLOOR-FOOT**”.

7 Floor Board Reference Volume (RV-FLOOR-BOARD)

RV-FLOOR-BOARD is composed of the following elements:

7.1 On a plane through $Z = 70$, a simple, closed polygon whose edges pass through the following $[X_F, Y]$ vertices sequentially:

- a. $[650, 890]$, $[825, 890]$, $[1350, 750]$, $[1350, 710]$, $[750, 800]$, $[650, 800]$, $[650, 890]$.

7.2 Once the surface in §7.1 is fully defined, it must be extruded along Z to $Z = 450$.

7.3 Once the volume in §7.2 is fully defined, it must be trimmed with a plane passing through the following three points with all material above the plane discarded.

- a. $[X_F = 1350, 730, 200]$, $[X_F = 1350, 710, 200]$, $[X_F = 1000, 890, 400]$.

The fully defined volume in §7.3 is “**RV-FLOOR-BOARD**”.

8 Floor Bib Reference Volume (RV-FLOOR-BIB)

RV-FLOOR-BIB is composed of the following elements:

8.1 On a plane through $Z = 0$, a simple, closed polygon whose edges pass through the following $[X, Y]$ vertices sequentially:

- a. $[X_F = 425, 0]$, $[X_F = 425, 100]$, $[X_F = 1075, 300]$, $[X_F = 1200, 300]$, $[X_F = 1200, 0]$, $[X_F = 425, 0]$.

8.2 Once the surface in §8.1 is fully defined, it must be extruded along Z to $Z = 50$.

The fully defined volume in §8.2 is “**RV-FLOOR-BIB**”.

9 Floor Leading Edge Device (RV-FLOOR-LED)

RV-FLOOR-LED is composed of the following elements:

9.1 An axis-aligned cuboid, which has one interior diagonal defined by the points:

- a. $[X_F = 1075, 310, 50]$, $[X_F = 1225, 600, 150]$.

9.2 Once the volume in §9.1 is fully defined, it must be trimmed with the sheet defined in §4.15 with all material above the sheet discarded.

The fully defined volume in §9.2 is “**RV-FLOOR-LED**”.

10 Floor Corner Reference Volume (RV-FLOOR-CORNER)

RV-FLOOR-CORNER is composed of the following elements:

10.1 On a plane through $Z = 50$, a simple, closed polygon whose edges pass through the following $[X, Y]$ vertices sequentially:

a. $[X_R = -825, 750]$, $[X_R = -825, 625]$, $[X_R = -495, 580]$, $[X_R = -495, 510]$, $[X_R = -335, 420]$, $[X_R = -335, 750]$, $[X_R = -825, 750]$.

10.2 Once the surface in §10.1 is fully defined, it must be extruded along Z to $Z = 85$.

10.3 Once the volume in §10.2 is fully defined, it must be trimmed with a plane passing through the following three points with all material outboard of the plane discarded.

a. $[X_F = 1100, 770, 50]$, $[X_R = -335, 700, 50]$, $[X_R = -335, 700, 100]$

The fully defined volume in §10.3 is “**RV-FLOOR-CORNER**”.

11 Plank Reference Volume (RV-PLANK)

RV-PLANK is composed of the following elements:

11.1 On a plane through $Z=0$, a simple, closed polygon whose edges pass through the following $[X, Y]$ vertices sequentially:

a. $[X_F=430, 0]$, $[X_F=430, 75]$, $[X_F=690, 125]$, $[X_R=-1300, 125]$, $[X_R=-350, 50]$, $[X_R=-350, 0]$, $[X_F=430, 0]$

11.2 Once the surface in §11.1 is fully defined, a fillet of radius 25mm must be applied at vertex at $[X_F=430, 75]$ and a fillet of radius 2000mm must be applied at the vertices at $[X_F=690, 125]$ and $[X_R=-1300, 125]$.

11.3 Once the surface in §11.2 is fully defined it must be extruded along Z to $Z=-10$.

11.4 Once the volume in §11.3 is fully defined; a chamfer of 6mm x 100mm must be applied to the lower edge at $X_R=-350$ and a chamfer of 6mm x 12mm must be applied to the remaining lower edges.

11.5 The fully defined volume in §11.4 is “**RV-PLANK**”.

12 Front Bodywork Reference Volume (RV-BODY-FRONT)

RV-BODY-FRONT is composed of the following elements:

12.1 A cylinder of diameter 11,000mm centred on the Y -Aligned axis $[X_C, Z] = [-1000, -4853]$, extruded between $Y = 0$, to $Y = 400$.

12.2 On a plane through $Y = 0$, a simple, closed polygon whose edges pass through the following $[X, Z]$ vertices sequentially:

a. $[X_C = -875, 195]$, $[X_C = -875, 645]$, $[X_F = -1300, 645]$, $[X_F = -1300, 125]$, $[X_F = -1000, 125]$, $[X_C = -1830, 225]$, $[X_C = -875, 195]$.

12.3 Once the surface in §12.2 is fully defined, it must be extruded along Y to $Y = 400$.

- 12.4** Once the volumes in §12.1 and §12.3 are fully defined, they must be combined with ALL non-overlapping regions discarded.
- 12.5** On a plane through $Y = 0$, a simple, closed polygon whose edges pass through the following $[X_C, Z]$ vertices sequentially:
- $[-875, 75], [320, 75], [320, 695\ 680], [0, 695\ 680], [0, 770], [-350, 770], [-350, 645], [-875, 645], [-875, 75]$.
- 12.6** Once the surface in §12.5 is fully defined, it must be extruded along Y to $Y = 400$.
- 12.7** An axis-aligned cuboid, which has one interior diagonal defined by the points:
- $[X_C, 170, 695\ 680], [X_C = 75, 400, 970]$.
- 12.8** Once the volumes in §12.4, §12.6 and §12.7 are fully defined, they must be combined to make one unified volume.
- 12.9** On a plane through $Z = 75$, a simple, closed polygon whose edges pass through the following $[X, Y]$ vertices sequentially:
- $[X_F = -1300, 0], [X_F = -1300, 150], [X_C = -1830, 200], [X_C = -1015, 265], [X_C = -400, 400], [X_C = 75, 400], [X_C = 75, 170], [X_C = 320, 170], [X_C = 320, 0], [X_F = -1300, 0]$.
- 12.10** Once the surface in §12.9 is fully defined, it must be extruded along Z to $Z = 970$.
- 12.11** Once the volumes in §12.8 and §12.10 are fully defined, they must be combined with all non-overlapping regions discarded.
- The fully defined volume in §12.11 is “**RV-BODY-FRONT**”
- 12.12** **RV-BODY-FRONT** is further split by the planes defined in Article 2.7:
- RV-NOSE** refers to a sub part of **RV-BODY-FRONT** forward of $X_A = 0$.
 - RV-CH-FRONT** refers to a sub part of **RV-BODY-FRONT** between $X_A = 0$ and a plane through $X_C = -875$.
 - RV-CH-MID** refers to a sub part of **RV-BODY-FRONT** rearwards of a plane through $X_C = -875$.
- The fully defined volume in §12.12a is “**RV-NOSE**”.
- The fully defined volume in §12.12b is “**RV-CH-FRONT**”.
- The fully defined volume in §12.12c is “**RV-CH-MID**”.
- 13** **Survival Cell Front Minimum Reference Volume (RV-CH-FRONT-MIN)**
- RV-CH-FRONT-MIN** is composed of the following elements:
- 13.1** A volume bounded by $X_C = -2030$ and $X_C = -875$ that must be symmetrical about $Y = 0$, and when cut with any X plane, the cross section must:
- Contain a four-sided section, with two sides parallel to Z .
 - Have width that varies linearly from 268 at $X_C = -2030$ to 380mm at $X_C = -1330$ and then linearly to 490mm at $X_C = -875$.
 - Have height at $Y = 0$ that varies linearly from 300 at $X_C = -2030$ to 415 at $X_C = -875$.

- d. Have the side visible from above, a convex circular arc, with radius varying linearly from $R = 400$ at $X_C = -2030$ to $R = 2500$ at $X_C = -875$.
- e. Have the side visible from below, a convex circular arc, with a constant radius of $R = 2500$.

13.2 Once the volume in §13.1 is fully defined, it must be trimmed with the plane $X_A = 0$ with all material ahead of this plane discarded.

13.3 Once the volume in §13.2 is fully defined, radii with a convex radius of curvature of 50mm must be applied to the longitudinal edges, drawn tangent to both surfaces and perpendicular to the boundary.

The fully defined volume in §13.3 is “RV-CH-FRONT-MIN”.

14 Mirror Body Reference Volume (RV-MIRROR-BODY)

RV-MIRROR-BODY is composed of the following elements:

14.1 On a plane through $Z = 640$, a simple, closed polygon whose edges pass through the following [X, Y] vertices sequentially:

- a. $[X_C = -830, 470]$, $[X_C = -730, 470]$, $[X_C = -650, 680]$, $[X_C = -750, 680]$, $[X_C = -830, 470]$.

14.2 Once the surface in §14.1 is fully defined, it must be extruded along Z to $Z = 720$.

The fully defined volume in §14.2 is “RV-MIRROR-BODY”.

15 Driver Cooling Reference Volume (RV-DRI-COOL)

RV-DRI-COOL is composed of the following elements:

15.1 An axis-aligned cuboid, which has one interior diagonal defined by the points:

- a. $[X_A = 100, 0, 550]$, $[X_A = 525, 125, 675]$.

15.2 A cylinder of diameter 11 065mm, centred on the Y-Aligned axis $[X_C, Z] = [-1000, -4855]$, extruded between $Y = 0$, to $Y = 125$.

15.3 Once the volumes in §15.1 and §15.2 are fully defined, they must be combined with all non-overlapping regions discarded.

The fully defined volume in §15.3 is “RV-DRI-COOL”.

16 Sidepod Reference Volume (RV-SIDEPOD)

RV-SIDEPOD is composed of the following elements:

16.1 On a plane through $Z = 125$, a simple, closed polygon whose edges pass through the following $[X_F, Y]$ vertices sequentially:

- a. $[900, 0]$, $[900, 275]$, $[1200, 715]$, $[1300, 715]$, $[1300, 0]$, $[900, 0]$.

16.2 Once the surface in §16.1 is fully defined, it must be extruded along Z to $Z = 600$.

The fully defined volume in §16.2 is “RV-SIDEPOD”.

17 Engine Cover Reference Volume (RV-EC)

RV-EC is composed of the following elements:

17.1 On a plane through $Z = 50$, a simple, closed polygon whose edges pass through the following [X, Y] vertices sequentially:

- a. $[X_F = 1300, 0]$, $[X_F = 1300, 715]$, $[X_R = -1500, 715]$, $[X_R = -500, 575]$, $[X_R = -500, 350]$, $[X_R = -50, 300]$, $[X_R = -50, 0]$, $[X_F = 1300, 0]$.

17.2 Once the surface in **§17.1** is fully defined, it must be extruded along Z to Z = 600.

17.3 Once the volume in **§17.2** is fully defined, it must be trimmed with a plane passing through the following three points with all material above the plane discarded.

- a. $[X_C, 0, 600]$, $[X_C, 725, 600]$, $[X_R = -50, 0, 350]$.

17.4 On a plane through Y=0, a simple, closed polygon whose edges pass through the following [X, Z] vertices sequentially:

- a. $[X_C = 320, 50]$, $[X_R = -50, 50]$, $[X_R = -50, 600]$, $[X_C = 500, 970]$, $[X_C = 320, 970]$, $[X_C = 320, 50]$.

17.5 Once the surface in **§17.4** is fully defined, it must be extruded along Y to Y = 400.

17.6 Once the volume in **§17.5** is fully defined, it must be trimmed with a plane passing through the following three points with all material outboard of the plane discarded.

- a. $[X_R = -500, 350, 50]$, $[X_R = -50, 300, 50]$, $[X_R = -50, 300, 600]$.

17.7 On a plane through Y=0, a simple, closed polygon whose edges pass through the following [X, Z] vertices sequentially:

- a. $[X_R = -160 - 150, 760 825]$, $[X_R = -395 - 900, 760 950]$, $[X_C = 500, 970]$, $[X_C = 500, 500]$, $[X_R = -160 - 50, 500]$, $[X_R = -160 - 150, 760 825]$.

17.8 Once the surface in **§17.7** is fully defined, it must be extruded along Y to Y = 25.

17.9 An axis-aligned cuboid, which has one interior diagonal defined by the points:

- a. $[X_C = 75, 170, 50]$, $[X_C = 320, 400, 970]$.

17.10 Once the volumes in **§17.3**, **§17.6**, **§17.8** and **§17.9** are fully defined they must be united to create a single unified volume.

The fully defined volume in **§17.10** is “RV-EC”.

18 Bodywork Aperture Reference Volume (RV-BW-APERTURE)

RV-BW-APERTURE is composed of the following elements:

18.1 On a plane through Z = 375, a simple, closed polygon whose edges pass through the following [X, Y] vertices sequentially:

- a. $[X_F = 1400, 380]$, $[X_R = -800, 80]$, $[X_R = -800, 400]$, $[X_R = -1650, 600]$, $[X_F = 1400, 600]$, $[X_F = 1400, 380]$.

18.2 Once the surface in **§18.1** is fully defined, it must be extruded along Z to Z = 700.

The fully defined volume in **§18.2** is “RV-BW-APERTURE”.

19 Tail Reference Volume (RV-TAIL)

RV-TAIL is composed of the following elements:

19.1 On a plane through Y = 0, a simple, closed polygon whose edges pass through the following $[X_{DIF}, Z]$ vertices sequentially:

- a. $[-110, 0], [-110, 480\ 500], [40\ 260, 480\ 500], [450, 380], [760, 380], [760, 175], [450, 175], [10, 0], [-110, 0]$.

19.2 Once the surface in **§19.1** is fully defined, it must be extruded along Y to $Y = 145$.

19.3 On a plane through $Z = 0$, a simple, closed polygon whose edges pass through the following $[X_{DIF}, Y]$ vertices sequentially:

- a. $[-110, 0], [760, 0], [760, 60], [10, 145], [-110, 145], [-110, 0]$.

19.4 Once the surface in **§19.3** is fully defined, it must be extruded along Z to $Z = 480\ 500$.

19.5 Once the volumes in **§19.2** and **§19.4** are fully defined, they must be combined with all non-overlapping regions discarded.

The fully defined volume in **§19.5** is “RV-TAIL”.

20 Tailpipe Reference Volume (RV-TAILPIPE)

RV-TAILPIPE is composed of the following elements:

20.1 An axis-aligned cuboid, which has one interior diagonal defined by the points:

- a. $[X_R = -55, 0, 350], [X_R = 400, 75, 550]$.

The fully defined volume in **§20.1** is “RV-TAILPIPE”.

21 Front Wing Reference Section (RS-FW-SECTION)

RS-FW-SECTION is composed of the following elements:

21.1 A plane through the following three points:

- a. $[X_F = -1250, 100, 0], [X_F = -1025, 700, 0], [X_F = -1025, 700, 275]$.

The fully defined plane in **§21.1** is “RS-FW-SECTION”.

22 Front Wing Profiles Reference Volume (RV-FW-PROFILES)

RV-FW-PROFILES is composed of the following elements:

22.1 On a plane through $X_F = -1250$, a simple, closed polygon whose edges pass through the following $[Y, Z]$ vertices sequentially:

- a. $[0, 60], [100, 60], [675, 115], [675, 275], [400, 300], [0, 440\ 200], [0, 60]$.

22.2 Once the surface in **§22.1** is fully defined, it must be extruded along X to $X_F = -475$.

22.3 Once the volume in **§22.2** is fully defined, it must be trimmed using the plane defined in **§21.1** with all material forward of the plane discarded.

22.4 Once the volume in **§22.3** is fully defined, it must be trimmed with a plane passing through the following three points with all material rearward of the plane discarded.

- a. $[X_F = -750, 0, 0], [X_F = -500, 400, 0], [X_F = -500, 400, 275]$.

The fully defined volume in **§22.4** is “RV-FW-PROFILES”.

23 Front Wing Endplate Body Reference Volume (RV-FWEP-BODY)

RV-FWEP-BODY is composed of the following elements:

23.1 An axis-aligned cuboid, which has one interior diagonal defined by the points:

a. $[X_F = -1250, 575, 75], [X_F = -300, 680, 375]$.

23.2 Once the volume in §23.1 is fully defined, it must be trimmed using the plane defined in §21.1 with all material forward of the plane discarded.

23.3 A cylinder of diameter 925mm centred on the Y-Aligned axis $[X_F, Z] = [0, 360]$, extruded between $Y = 560$, to $Y = 900$.

23.4 Once the cylinder in §23.3 is fully defined, it must be used to trim the volume in §23.2 with both the cylinder and all overlapping regions discarded.

23.5 Once the volume in §23.4 is fully defined, it must be trimmed with a plane passing through the following three points with all material above the plane discarded.

a. $[X_F = -750, 675, 375], [X_F = -1050, 675, 250], [X_F = -1050, 600, 250]$.

The fully defined volume in §23.5 is “RV-FWEP-BODY”.

24 Front Wing Endplate Outer Footplate Reference Volume (RV-FWEP-OFP)

RV-FWEP-OFP is composed of the following elements:

24.1 An axis-aligned cuboid, which has one interior diagonal defined by the points:

a. $[X_F = -1250, 750, 75], [X_F = -300, 900, 170]$.

24.2 Once the volume in §24.1 is fully defined, it must be trimmed using the plane defined in §21.1 with all material forward of the plane discarded.

24.3 Once the volume in §24.2 is fully defined, it must be trimmed with the cylinder defined in §23.3 with both the cylinder and all overlapping regions discarded.

The fully defined volume in §24.3 is “RV-FWEP-OFP”.

25 Front Wing Endplate Inner Footplate Reference Volume (RV-FWEP-IFP)

RV-FWEP-IFP is composed of the following elements:

25.1 An axis-aligned cuboid, which has one interior diagonal defined by the points:

a. $[X_F = -1250, 560, 75], [X_F = -300, 750, 120]$.

25.2 Once the volume in §25.1 is fully defined, it must be trimmed using the plane defined in §21.1 with all material forward of the plane discarded.

25.3 Once the volume in §25.2 is fully defined, it must be trimmed with the cylinder defined in §23.3 with both the cylinder and all overlapping regions discarded.

The fully defined volume in §25.3 is “RV-FWEP-IFP”.

26 Front Wing Endplate Diveplane Reference Volume (RV-FWEP-DIVEPLANE)

RV-FWEP-DIVEPLANE is composed of the following elements:

26.1 An axis-aligned cuboid, which has one interior diagonal defined by the points:

a. $[X_F = -950, 575, 175], [X_F = -550, 900, 340]$.

26.2 Once the volume in §26.1 is fully defined, it must be trimmed with the plane defined in §23.5 with all material above the plane discarded.

The fully defined volume in §26.2 is “RV-FWEP-DIVEPLANE”.

27 Front Wing Strake Reference Volume (RV-FW-STRAKE)

RV-FW-STRAKE is composed of the following elements:

27.1 An axis-aligned cuboid, which has one interior diagonal defined by the points:

- a. $[X_F = -1125, 450, 75], [X_F = -375, 555, 200]$.

27.2 Once the volume in **§27.1** is fully defined, it must be trimmed using the plane defined in **§21.1** with all material forward of the plane discarded.

The fully defined volume in **§27.2** is “**RV-FW-STRAKE**”.

28 Front Wing Sensor Reference Volume (RV-FW-SENSOR)

RV-FW-SENSOR is composed of the following elements:

28.1 An axis-aligned cuboid, which has one interior diagonal defined by the points:

- a. $[0, 0, 0], [60, 15, 50]$.

28.2 A cylinder of diameter 30mm centred on the X-Aligned axis $[Y, Z] = [7.5, 50]$, extruded between $X = 0$, to $X = 60$.

28.3 Once the volumes in **§28.1** and **§28.2** are fully defined, they must be united to create a single unified volume.

The fully defined volume in **§28.3** is “**RV-FW-SENSOR**”.

29 Camera 2 Reference Volume (RV-CAMERA-2)

RV-CAMERA-2 is composed of the following elements:

29.1 An axis-aligned cuboid, which has one interior diagonal defined by the points:

- $[X_F = -150, 0, 325], [X_F = -450, -330, 550]$.

29.2 Once the volume in **§29.1** is fully defined, it must be trimmed with the following planes:

- a. a plane passing through the following three points with all material above the plane discarded:
- i. $[X_F = -1250, 0, 220], [X_A, 0, 550], [X_A, -200, 550]$.
- b. a plane passing through the following three points with all material inboard of the plane discarded:
- i. $[X_F = -1250, -85, 0], [X_A, -135, 0], [X_A, -135, 200]$.

The fully defined volume in **§29.2** is “**RV-CAMERA-2**”.

30 Rear Wing Profiles Reference Volume (RV-RW-PROFILES)

RV-RW-PROFILES is composed of the following elements:

30.1 An axis-aligned cuboid, which has one interior diagonal defined by the points:

- a. $[X_R = 165, 0, 725], [X_R = 630, 575, 880]$.

30.2 Once the volume in **§30.1** is fully defined, it must be trimmed with a plane passing through the following three points with all material below the plane discarded.

- a. $[X_R = 165, 150, 725], [X_R = 165, 575, 785], [X_R = 630, 575, 785]$.

The fully defined volume in **§30.2** is “**RV-RW-PROFILES**”.

31 Rear Wing Endplate Reference Volume (RV-RWEP-BODY)

RV-RWEP-BODY is composed of the following elements:

- 31.1** On a plane through $X_R = 150$, a simple, closed polygon whose edges pass through the following [Y, Z] vertices sequentially:
- [345, 250], [345, 425], [535, 700], [535, 880], [575, 880], [575, 675], [375, 375], [375, 250], [345, 250].
- 31.2** Once the surface in **31.1** is fully defined, it must be extruded along X to $X_R = 750$.
- 31.3** Once the volume in **31.2** is fully defined, it must be trimmed with the following planes:
- A plane passing through the following points [X_R, Y, Z], with all material forward of the plane discarded:
 - [160, 575, 700], [375, 575, 250], [375, 375, 250].
 - A plane passing through the following points [X_R, Y, Z], with all material rearward of the plane discarded:
 - [750, 575, 625], [625, 575, 250], [625, 375, 250].
 - A plane passing through following points [X_R, Y, Z], with all material below the plane discarded:
 - [450, 425, 250], [750, 425, 325], [750, 400, 325].

The fully defined volume in **31.3** is “**RV-RWEP-BODY**”.

32 Rear Wing Pylon Reference Volume (RV-RW-PYLON)

RV-RW-PYLON is composed of the following elements:

- 32.1** On a plane through $Y = 50$, a simple, closed polygon whose edges pass through the following [X, Z] vertices sequentially:
- [X_R, 300], [X_R, 450], [X_R = 200, 825], [X_R = 450, 825], [X_{DIF} = 400, 300], [X_R, 300].
- 32.2** Once the surface in **32.1** is fully defined, it must be extruded along Y to $Y = 110$.

The fully defined volume in **32.2** is “**RV-RW-PYLON**”.

33 Stay / Bracket / Support / Fairing Reference Volumes

Each individual Stay, Bracket, Support or Fairing Volume is composed of the elements listed, by row, in the following table.

In each row, the fully defined **Reference Volume** is an axis-aligned cuboid, which has one interior diagonal defined by the listed points.

Reference Volumes with multiple pairs of points are comprised of multiple cuboids. Each individual cuboid must first be defined sequentially by the respective pair of points and all cuboids combined to form the single **Reference Volume**.

33.	Name	Code (RV-)	Point 1 [X, Y, Z]	Point 2 [X, Y, Z]
1	Hanger	“HANGER”	[0, 0, 0]	[60, 10, 70]

2	Floor Sphere	“FLOOR-SPHERE”	$[X_R = -350, 365, 55]$	$[X_R = -330, 385, 65]$
3	Floor Fence	“FLOOR-FENCE”	$[X_R = -315, 170, 25]$	$[X_R = 135, 310, 225]$
4	Floor Board Brace	“FLOOR-BRACE”	$[X_F = 650, 200, 200 70]$	$[X_F = 800, 890, 450]$
5	Roll Hoop	“ROLL-HOOP”	$[X_C = 0, 0, 695 680]$	$[X_C = 320, 170, 970]$
6	Mirror Inner Stay	“MIRROR-ISTAY”	a) $[X_C = -830, 175, 600]$ b) $[X_C = -830, 175, 570]$	a) $[X_C = -730, 500, 665]$ b) $[X_C = -730, 260, 600]$
7	Mirror Rear Stay	“MIRROR-RSTAY”	$[X_C = -765, 500, 450]$	$[X_C = -450, 630, 700]$
8	Tailpipe Bracket	“TAILPIPE-BRACKET”	$[0, 0, 0]$	$[30, 25, 80]$
9	Front Wing Pylon	“FW-PYLON”	$[X_F = -1200, 50, 60]$	$[X_F = -950, 150, 275]$
10	Front Wing Adjuster	“FW-ADJUSTER”	$[0, 0, 0]$	$[60, 25, 85]$
11	Front Wing SLM CL Fairing	“FW-SLM-CL-FAIRING”	$[X_F = -1025, 0, 60]$	$[X_F = -700, 25, 300]$
12	Front Wing SLM Mid	“FW-SLM-MID”	$[X_F = -1200 -1150, 200, 70]$	$[X_F = -750 -700, 400, 300]$
13	Front Wing SLM Linkage	“FW-SLM-LINKAGE”	$[0, 0, 0]$	$[15, 15, 200]$
14	Rear Wing Brace	“RW-BRACE”	$[X_R = 375, 0, 310]$	$[X_R = 625, 375, 350]$
15	Rear Wing Separator	“RW-SEPARATOR”	$[0, 0, 0]$	$[30, 10, 30]$
16	Rear Wing SLM Fairing	“RW-SLM-FAIRING”	$[X_R = 165, 0, 725]$	$[X_R = 600, 25, 950]$
17	Rear Wing Bracket	“RW-BRACKET”	$[0, 0, 0]$	$[60, 30, 30]$
16	Secondary Roll	SECONDARY-ROLL	$[X_C = -1066, -25, 600]$	$[X_C = -835, 25, 705]$
18	Slip Sensor	“SLIP”	$[X_F = 50, -25, 120]$	$[X_F = 450, 25, 280]$

34 Reference Surfaces

Each individual **Reference Surface** is composed of the elements listed, by row, in the following table.

Each fully defined **Reference Surface** is a simple, closed polygon, that lies exactly on the listed plane, with edges that pass through the listed vertices sequentially.

34.	Name	Code (RS-)	Plane	Ref.	Vertices
1	Floor Foot	“FLOOR-FOOT”	Z = 50	$[X_F, Y]$	$[675, 700], [675, 800], [750, 850], [1225, 725], [1225, 650], [675, 700]$
2	Sidewall	“FLOOR-SIDEWALL”	Y = 345 325	$[X_R, Z]$	$[-75, 40], [-75, 160 115], [150, 160 145], [300, 210], [300, 40 95], [50, 40], [-75, 40]$

3	Floor Body	“FLOOR-BODY”	Z = 450	[X, Y]	[X _F = 450, 0], [X _F = 450, 50], [X _F = 1150, 250], [X _F = 1150, 730], [X _R = -360, 680], [X _R = -360, 350], [X _R = 290, 350], [X _R = 290, 0], [X _F = 450, 0]
4	Floor Reference	“FLOOR-REF”	Z = 300	[X, Y]	[X _F = 450, 0], [X _F = 450, 50], [X _F = 1080, 200], [X _F = 1400, 310], [X _R = -1100, 310], [X _R = -800, 260], [X _R = -545, 200], [X _R = -545, 70], [X _R = -345, 50], [X _R = -345, 0], [X _F = 450, 0]
5	Floor Step	“FLOOR-STEP”	Z = 300	[X, Y]	[X _F = 1250, 340], [X _F = 1400, 390], [X _R = -1050, 390], [X _R = -775, 350], [X _R = -625, 300], [X _R = -500, 475], [X _R = -400 -500, 475 575], [X _R = -400 -825, 600 620], [X _F = 1250, 690], [X _F = 1250, 330 340]
6	Floor Board	“FLOOR-BOARD”	Y = 600	[X _F , Z]	[675, 325], [1050, 325], [1300, 160], [1300, 90], [675, 90], [675, 325]
7	Nose	“NOSE”	Z = 0	[X, Y]	[X _F = -1200, 0], [X _F = -1175, 100], [X _C = -2030, 134], [X _C = -1330, 190], [X _C = -1330, 0], [X _F = -1200, 0]
8	Engine Cover	“EC”	Y = 0	[X, Z]	[X _R = -53, 50], [X _R = -53, 570], [X _R = -465 -75, 605 575], [X _R = -465 -150, 755 815], [X _R = -475, 850], [X _R = -400 -1000, 755 955], [X _C = 320, 967], [X _C = 320, 50], [X _R = -53, 50]
9	Bodywork Aperture	“BW-APERTURE”	Z = 350	[X, Y]	[X _F = 1400, 380], [X _R = -800, 80], [X _R = -800, 400], [X _R = -1650, 600], [X _F = 1400, 600], [X _F = 1400, 380]
10	Front Wing Profiles	“FW-PROFILES”	Z = 0	[X _F , Y]	[-1225, 0], [-1000, 675], [-700, 675], [-850, 0], [-1225, 0]
11	Front Wing Endplate Top	“FWEP-TOP”	Z = 0	[X _F , Y]	[-875, 895], [-425, 895], [-425, 670], [-1000, 670], [-875, 895]
12	Front Wing Endplate Side	“FWEP-SIDE”	Y = 700	[X _F , Z]	[-950, 80], [-975, 175], [-625, 350], [-475, 350], [-460, 225], [-400, 80], [-950, 80]
13	Rear Wing Endplate	“RWEP”	Y = 0	[X _R , Z]	[310 250, 870], [740, 870], [740 -700], [625, 310], [375, 310], [230 165, 700], [245 165, 800], [310 250, 870]
14	ERS Protection Surface	“PU-ERS”	Y=280	[X, Z]	[X _C = -365, 50], [X _C = -365, 170], [X _C = -70, 380], [X _{PU} = -100, 380], [X _{PU} = -100, 50], [X _C = -365, 50]
15	Front Deflector Top Edge	“FWH-TOP”	Y _w = -20	[X _w , Z _w]	[150, -160], [335, -160], [335, -110], [250, -140], [150, -140], [150, -160]

35 Forward Intrusion Laminar Reference Surface (RS-INTSN-LAM-FWD)

RS-INTSN-LAM-FWD is composed of the following elements:

35.1 On the plane Y=0, a profile of two lines passing through the following points [X_C, Z];

a. [-740, 0], [-875, 235], [-875, 650].

35.2 Once the profile in 35.1 is fully defined, it must be extruded in Y to Y = 500.

The fully defined surface in 35.2 is “RS-INTSN-LAM-FWD”.

36 Rearward Intrusion Laminar Reference Surface (RS-INTSN-LAM-RWD)

RS-INTSN-LAM-RWD is composed of the following elements:

- 36.1** On the plane $Y=0$, a profile of two lines passing through the following points $[X, Z]$;
- $[X_C = 0, 550]$, $[X_{PU} = -75, 450]$, $[X_{PU} = -75, 100]$.
- 36.2** Once the profile in **§36.1** is fully defined, it must be extruded in Y to $Y = 500$.
The fully defined surface in **§36.2** is “**RS-INTSN-LAM-RWD**”.

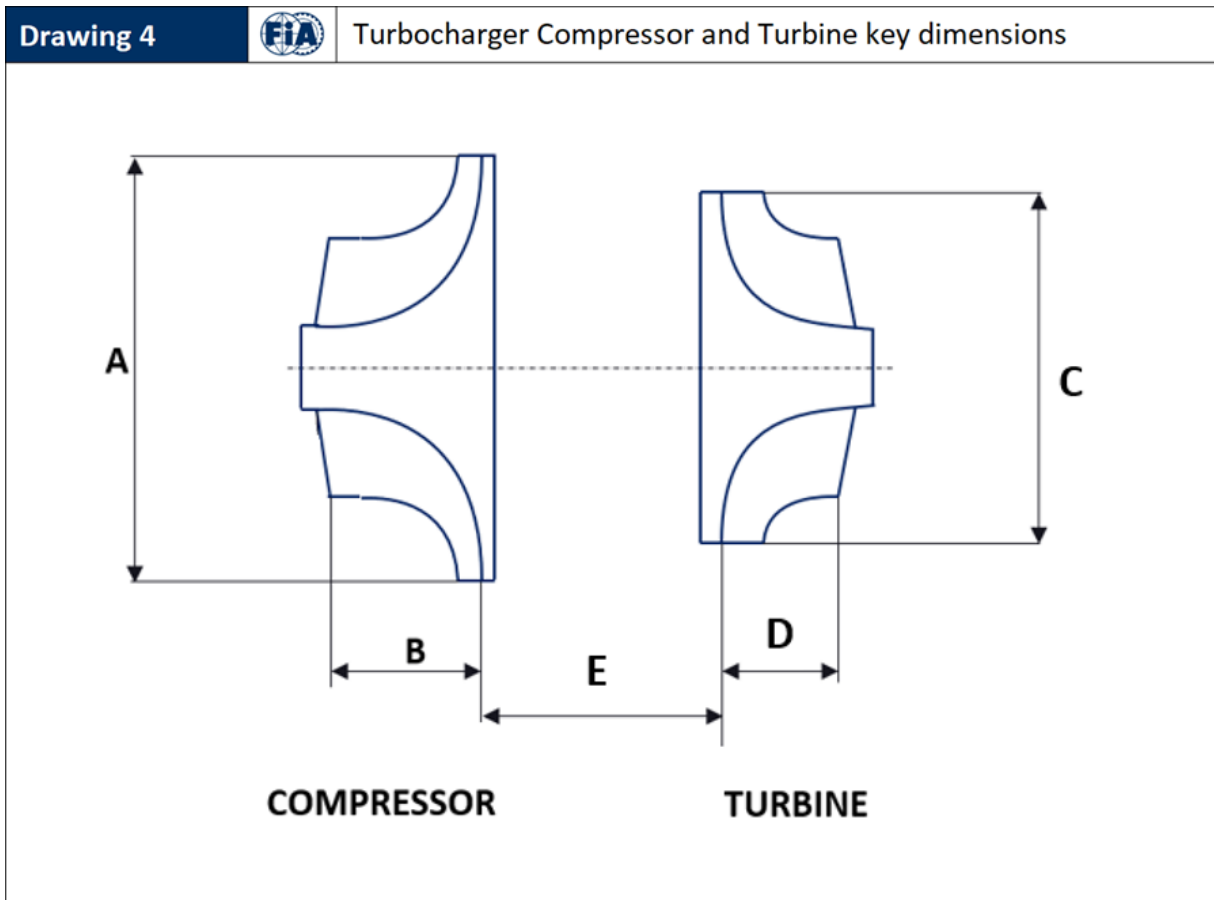
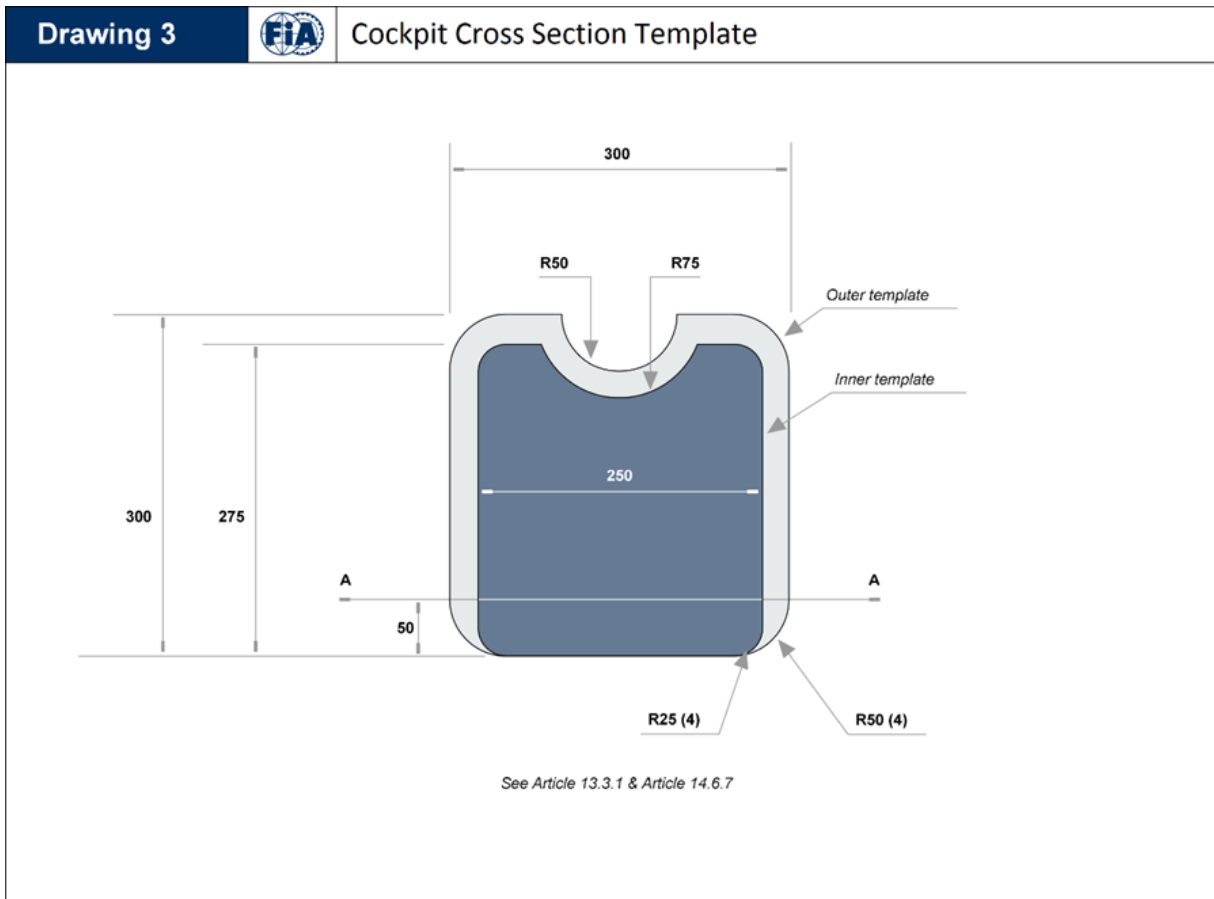

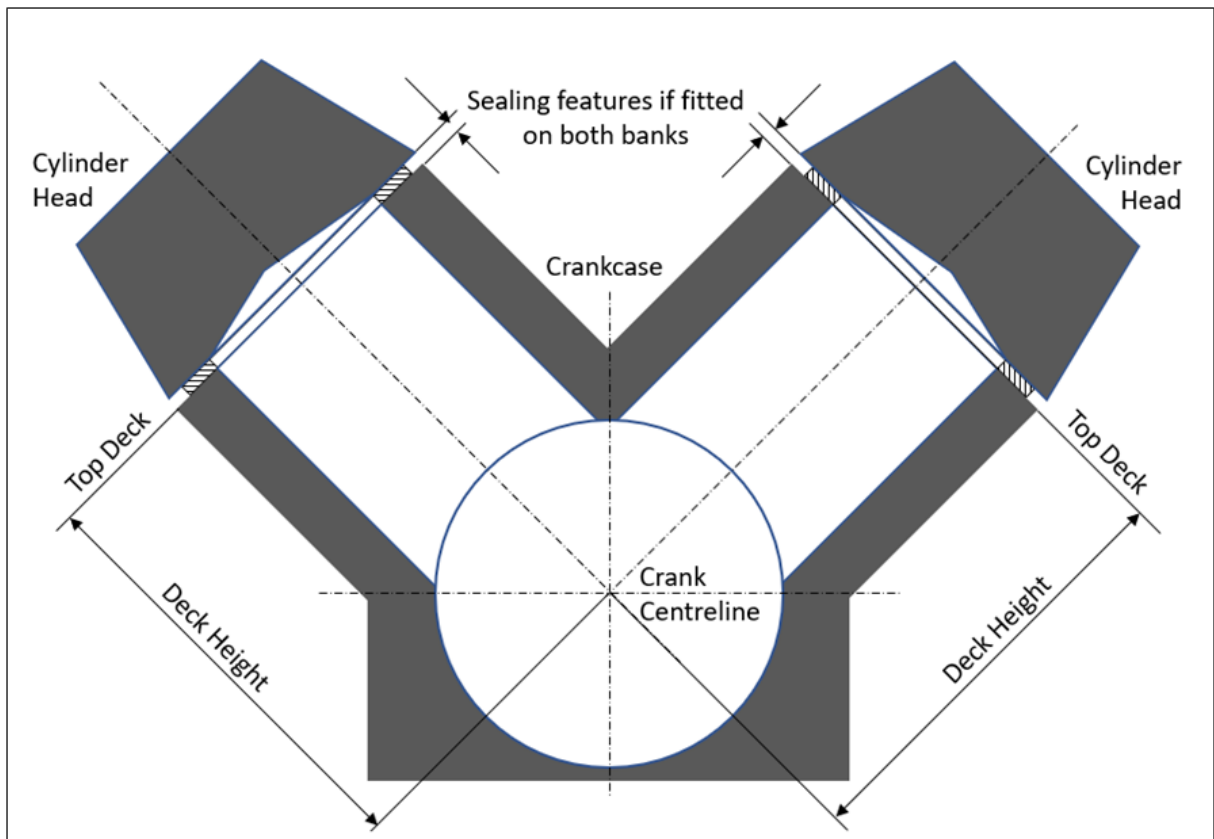
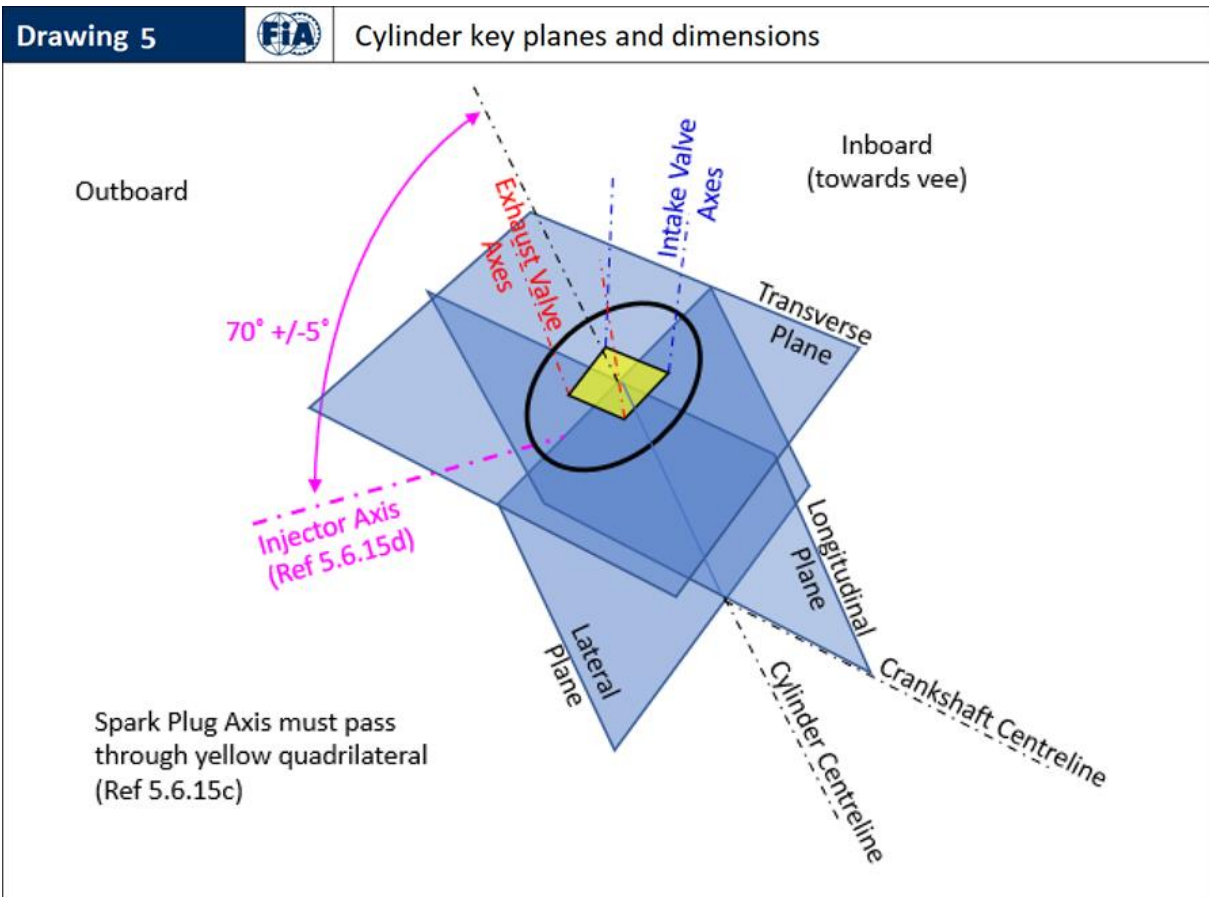

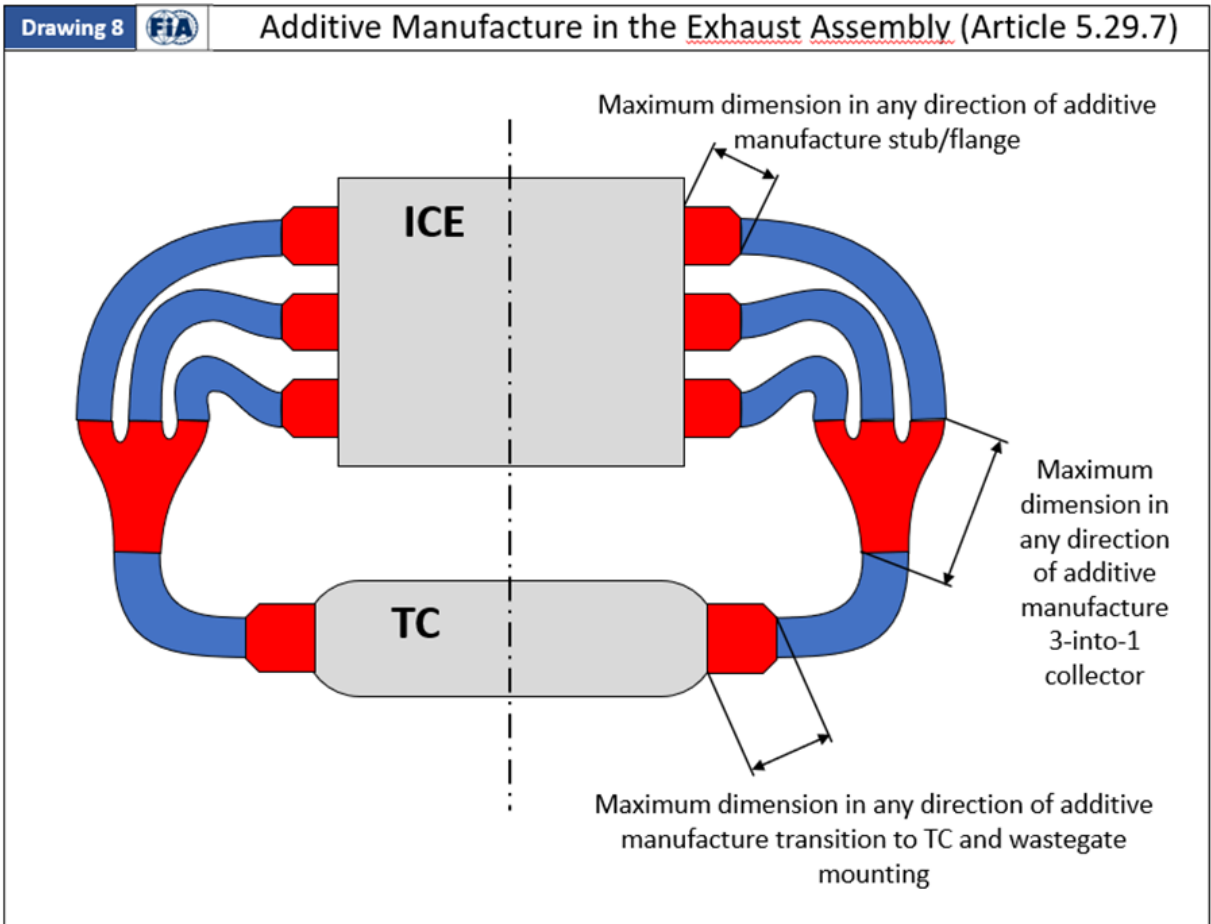
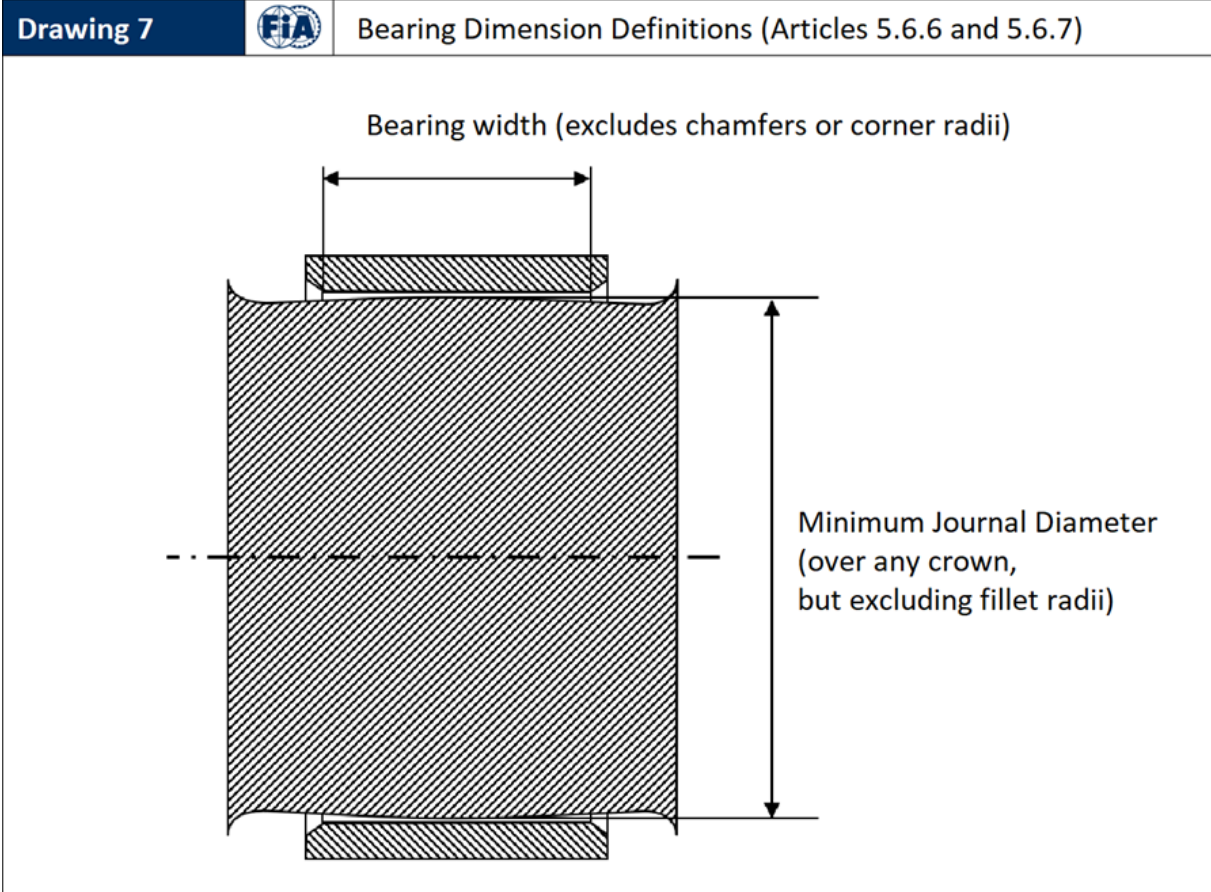

Drawing 9 **2026 PU ELEMENT MINIMUM MASS LIMITS (for reference only)**

ESME	MGUK	MGU-K Mechanical Transmission	ICE	TC	Powerbox
			No individual mass limit	Min 12kg	No individual mass limit
Min 35kg	Min 16kg	Assumed 4kg	Min ICE+TC+Powerbox 130kg		

2026 PU MASS ALLOWANCES AS WEIGHED					
	ESME Min Mass as weighed	MGUK Min Mass as weighed	Not weighed	ICE Min Mass as weighed	TOTAL PU MINIMUM MASS
Drive in MGUK	> 35kg	> 20kg	> -	> 130kg	> 185kg
Drive Split	> 35kg	> 18kg	> -	> 132kg	> 185kg
Drive in ICE	> 35kg	> 16kg	> -	> 134kg	> 185kg

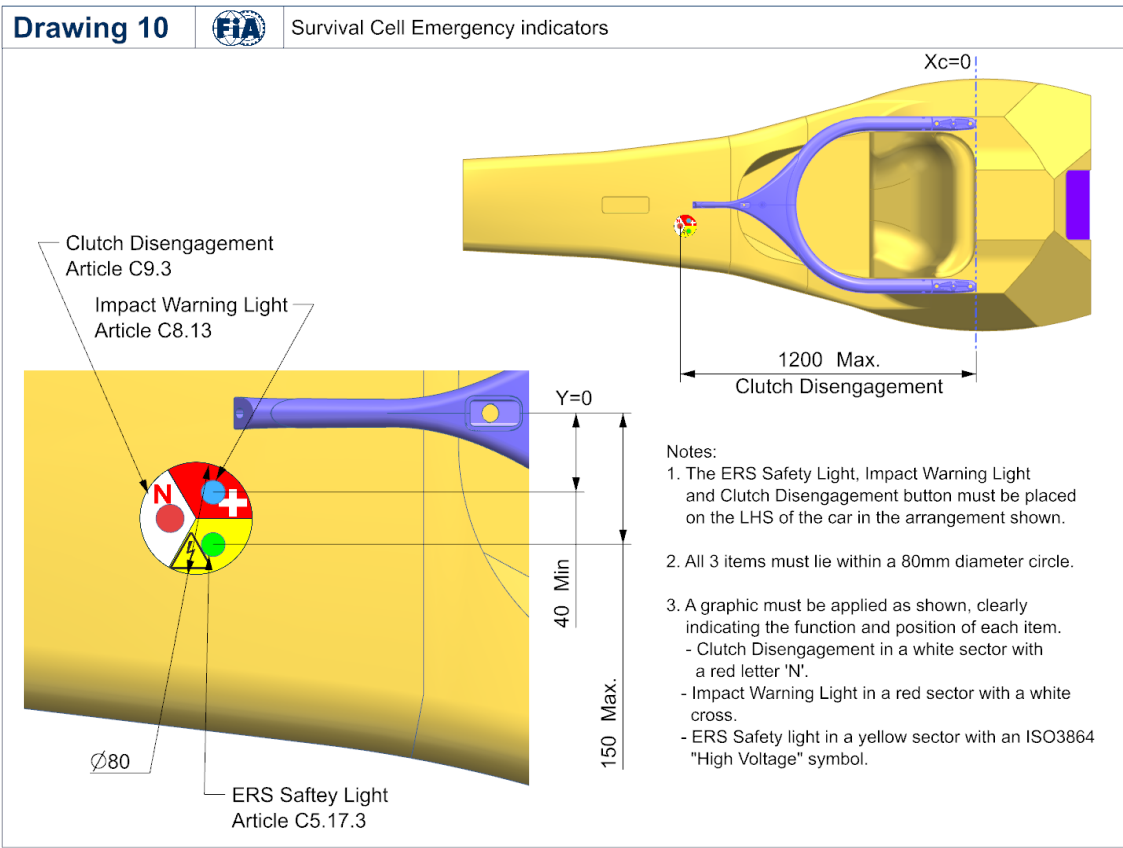

APPENDIX C4: POWER UNIT SYSTEMS, FUNCTIONS, COMPONENTS AND SUPPLY PERIMETER

Advisory Committee: PUAC

Governance: PU Manufacturers' Governance Agreement / WMSC

Table 1: 'Power Unit Components' below provides all category allocations and specific permissible upgrade schedule for every part of the PU.

Column 1 provides a description of the general area of the PU for the rows bracketed by the description and is for reference only.

Column 2, 'Item No' provides a sequential item number for ease of navigation within the table and is for reference only.

Column 3, 'List of PU functions/systems/components' provides a description of the functions, systems and components in enough detail to place any aspect of the PU into one of the columns. The understanding of what each of the elements listed refers to will be taken as that which is widely understood unless there are specific definitions elsewhere in the regulations. For these items, the definition will take precedence.

Column 4, 'PU Element' identifies which of the six 'Sealed Perimeter' PU elements (**ICE**, **TC**, EXH, MGU-K, ESME or **PU-CE**) the item belongs to (see also Column 5). If the item does not belong to any of these six elements, then 'EXC' is shown in the column.

Column 5, 'Sealed Perimeter' differentiates those items included in a **PU** element sealed perimeter ('INC') and those items excluded from a PU element sealed perimeter ('EXC').

The parts listed as 'INC' are included within the PU element shown in Column 4. Treatment of these items is defined in Article B8.2.

The parts listed as 'EXC' are not part of a PU element. Treatment of these items is defined in defined in Article B8.2.

Column 6, 'Supply Perimeter' differentiates those items included in the PU supply within **Power Unit** Maximum Supply Price described in Appendix C5 Article 1.4.

Column 7, 'Reference Volume' identifies which of the four PU Reference Volumes (RV-PU-; **ICE**, OT, **TC** or ERS) defined in Appendix C2 the item belongs to. If the item does not belong to any of these four elements, the 'EXC' is shown in the column.

Column 8, 'PU Mass Group' identifies which of the four PU Mass Groups (**ICE**, **TC**, MGU-K or ESME) the item belongs to. The minimum masses of the mass groups are defined in Articles C5.57.1, C5.35.4, C5. 1820.7 and C5. 1749.9 respectively. If the item does not belong to any of these four elements, the 'EXC' is shown in the column. For reference, Drawing 9 summarises all masses involved.

Columns 9-14, Upgrade Schedule (Homologation Status)' is described in Appendix C4.

Columns 9-13 show which season the upgrades described in Appendix C4, Article 3 are permitted. A tick in a green cell indicates that the item may be upgraded for that season while a cross in a red cell indicates the item may not be upgraded in that season and must be carried over from the previous season – both subject to the provisions described in Appendix C4, Article 3.

PU Area	Item No	List of PU functions/ systems/ components	PU ELEMENT	SEALED PERIMETER	SUPPLY PERIMETER	REFERENCE VOLUME	PU MASS GROUP	UPGRADE SCHEDULE (HOMOLOGATION STATUS)						COMPONENT CLASSIFICATION	ANCILLARY COMPONENTS	
								2026	2027	2028	2029	2030	ADUO			
ICE ASSEMBLY	1	Main ICE assembly comprising Crankcase, Cylinder heads (except combustion chamber and ports machining), Crankshaft, Camshaft (excluding camshaft lobe profiles), Cam drive, Cam covers, Front and rear covers, valves, finger followers, Internal gear drives, any part which provides a structural connection between the Survival Cell and the gearbox case through the ICE mounting studs.	ICE	INC	INC	ICE	ICE	✓	x	x	x	x	x	✓	LPUC	
	2	ICE-mounted water pumps, ICE oil pumps, ICE oil scavenge pumps, any air/oil separator Non-hydraulic actuators (to allow PU to function), ICE-mounted air valve compressors and storage bottles.	ICE	INC	INC	ICE	ICE	✓	x	x	x	x	x	✓	LPUC	YES
	3	Flywheel	EXC INC	EXC	INC	EXC ICE	ICE	✓	✓	✓	✓	✓	✓	✓	App G6 LPUC	
	4	Main ICE assembly comprising Combustion chamber surface and pre-chamber detail within cylinder heads, piston, connecting rod, camshaft lobe profiles, intake and exhaust ports, Valvegear air spring sub-assemblies.	ICE	INC	INC	ICE	ICE	✓	✓	x	✓	x	✓	✓	LPUC	
	5	Trumpets, Throttle system, Plenum	ICE	INC	INC	ICE	ICE	✓	✓	x	✓	x	✓	✓	LPUC	YES
	6	ICE intake air system components, other than those included in item 5 and downstream of those included in item 56 57	ICE	INC	INC	EXC	ICE	✓	✓	x	✓	x	✓	✓	LPUC	YES
	7	PU mounted fuel system components downstream of the High Pressure Fuel Pump: (e.g., high pressure fuel hoses, fuel rails)	ICE	INC	INC	ICE	ICE	✓	x	x	x	x	✓	✓	LPUC	YES
	8	High Pressure Fuel Pump	ICE	INC	INC	ICE	ICE	✓	x	x	x	x	✓	✓	SSPUC	YES
	9	ICE Fluid Filters (Oil, Fuel)	ICE	EXC	INC	ICE	ICE	✓	x	x	x	x	✓	✓	LPUC	
	10	Fuel Injectors	ICE	INC	INC	ICE	ICE	✓	x	x	x	x	x	x	SSPUC	YES

PU Area	Item No	List of PU functions/ systems/ components	PU ELEMENT	SEALED PERIMETER	SUPPLY PERIMETER	REFERENCE VOLUME	PU MASS GROUP	UPGRADE SCHEDULE (HOMOLOGATION STATUS)						COMPONENT CLASSIFICATION	ANCILLARY COMPONENTS
								2026	2027	2028	2029	2030	ADUO		
	11	Fuel Injector spray pattern tuning feature	ICE	INC	INC	ICE	ICE	✓	✓	x	✓	x	✓	LPUC	
	12	Knock Sensors	ICE	EXC	INC	ICE	ICE	✓	x	x	x	x	x	SSPUC	
	13	Spark Plugs	ICE	EXC	INC	ICE	ICE	✓	✓	x	✓	x	✓	LPUC	
EXHAUST	14	Engine exhaust system (including thermal insulation, excluding fasteners and seals)	EXH	INC	INC	ICE	ICE	✓	✓	x	✓	x	✓	LPUC	
	15	Exhaust fasteners and seals	EXH	EXC	INC	ICE	ICE	✓	✓	x	✓	x	✓	LPUC	
TURBO	16	TURBOCHARGER - Includes Compressor and Turbine Wheels, Shaft, Bearings, Centre, Compressor and Turbine Housings, Inlet VG Device, compressor inlet	TC	INC	INC	TC	TC and ICE	✓	✓	x	✓	x	✓	LPUC	
	17	Turbocharger-mounted electrical components (e.g. wiring looms, non-regulatory sensors)	TC	EXC	INC	TC	TC and ICE	✓	✓	x	✓	x	✓	LPUC	
WG / POP-OFF	18	Wastegate or similar	EXH	INC	INC	ICE	ICE	✓	✓	x	✓	x	✓	OSPUC	YES
	19	Pop-off valve or similar	ICE	INC	INC	ICE	ICE	✓	✓	x	✓	x	✓	OSPUC	YES
PU ELECTRICAL	20	ICE or EXH-mounted electrical components (e.g. wiring looms within legality volume, non-regulatory-sensors, actuators)	ICE	EXC	INC	ICE	ICE	✓	✓	x	✓	x	✓	LPUC	
	21	Clutch shaft regulatory torque sensor	EXC	EXC	EXC	EXC	EXC							App C6 [3F]	
	22	PU-mounted regulatory temperature and pressure sensors	ICE or TC or MGU-K or EXH or ES	EXC	INC	Linked to PU Element	Linked to PU Element	✓	x	x	x	x	x	SSPUC	
	23	Other regulatory PU sensors	EXC	EXC	EXC	EXC	EXC	✓	✓	x	✓	x	✓	SSPUC	
	24	Ignition coils	ICE	EXC	INC	ICE	ICE	✓	✓	x	✓	x	✓	DSPUC	
	25	FIA Standard ECU.	EXC	EXC	EXC	EXC	EXC							App C6 [11S]	
ERS - MGU-K	26	MGU-K excluding mechanical power transmission components	MGU-K	INC	INC	ERS	MGU-K	✓	x	✓	x	✓	x	LPUC	

PU Area	Item No	List of PU functions/ systems/ components	PU ELEMENT	SEALED PERIMETER	SUPPLY PERIMETER	REFERENCE VOLUME	PU MASS GROUP	UPGRADE SCHEDULE (HOMOLOGATION STATUS)						COMPONENT CLASSIFICATION	ANCILLARY COMPONENTS
								2026	2027	2028	2029	2030	ADUO		
	27	ICE mounted MGU-K mechanical power transmission components, housing assembly and mounting accessories	ICE	INC	INC	ICE and/or ERS	ICE	✓	x	✓	x	✓	x	LPUC	
	28	MGU-K mounted MGU-K mechanical power transmission components, housing assembly and mounting accessories	MGU-K	INC	INC	ICE and/or ERS	MGU-K	✓	x	✓	x	✓	x	LPUC	
	29	MGU-K regulatory Torque sensor: Field sensor assembly	MGU-K	EXC	INC	ICE and/or ERS	MGU-K or ICE	✓	x	✓	x	✓	x	SSPUC	
	30	MGU-K torque sensor signal conditioning module (SCM)	MGU-K	EXC	INC	EXC	MGU-K or ICE or ESME	✓	x	✓	x	✓	x	SSPUC	
	31	The MGU-K torque sensor shaft, mounting accessories and the mechanical connection elements between K and ICE, if applicable.	ICE and/or MGU-K	EXC	INC	ICE and/or ERS	MGU-K or ICE	✓	x	✓	x	✓	x	LPUC	
	32	ERS-K phase conductors, associated interfaces and mounting accessories. MGU-K terminal box	MGU-K	EXC	INC	ERS	MGU-K	✓	x	✓	x	✓	x	LPUC	
	33	MGU-K electrical components fitted outside of sealed perimeter of item 25 (e.g. wiring looms, non-regulatory sensors)	MGU-K	EXC	INC	ERS	MGU-K	✓	x	✓	x	✓	x	LPUC	
ERS - ES	34	ES Main Enclosure (ESME)	ES	INC	INC	ERS	ESME	✓	x	✓	x	✓	x	LPUC	
	35	Energy Store	ES	INC	INC	ERS	ESME	✓	x	✓	x	✓	x	LPUC	
	36	Regulatory DC sensors and Insulation monitoring device	ES	EXC	INC	ERS	ESME	✓	x	x	x	x	x	SSPUC	
	37	Safety devices (Fuses, Contactors, MSD, relays)	ES	EXC	INC	ERS	ESME	✓	x	✓	x	✓	x	LPUC	
	38	Busbars, connectors conductors, looms or any other component fitted inside the ESME that is not explicitly mentioned in any other rows of this table.	ES	EXC	INC	ERS	ESME	✓	x	✓	x	✓	x	LPUC	

PU Area	Item No	List of PU functions/ systems/ components	PU ELEMENT	SEALED PERIMETER	SUPPLY PERIMETER	REFERENCE VOLUME	PU MASS GROUP	UPGRADE SCHEDULE (HOMOLOGATION STATUS)						COMPONENT CLASSIFICATION	ANCILLARY COMPONENTS
								2026	2027	2028	2029	2030	ADUO		
PU-CE	39	CU-K	PU-CE	INC	INC	ERS	ESME	✓	x	✓	x	✓	x	LPUC	
	40	DC-DC Unit	PU-CE	INC	INC	ERS	ESME	✓	x	✓	x	✓	x	LPUC	
	41	Powerbox (ignition, injection, high pressure fuel pump driver)	PU-CE	EXC	INC	EXC	ICE	✓	x	x	x	x	x	SSPUC	
	42	General electrical devices inside the ESME, including Power distribution board, Driver for PU electric pumps, LV fuse box and any electronic box exclusively used for PU functionalities.	PU-CE	INC	INC	ERS	ESME	✓	x	✓	x	✓	x	LPUC	
	43	General electrical devices outside or on the ESME, including Power distribution board, Driver for PU electric pumps, LV fuse box and any electronic box exclusively used for PU functionalities.	PU-CE	INC	INC	EXC	ICE or ESME	✓	x	✓	x	✓	x	LPUC	
	44	Source of energy independent of the ES exclusively used for PU functionalities	ICE or PU-CE	EXC	INC	EXC	ICE or ESME	✓	x	✓	x	✓	x	LPUC	
OIL TANK	45	Main PU oil tank	ICE	INC	INC	OT	ICE	✓	x	x	x	x	✓	LPUC	YES
	46	Oil level sensor	ICE	EXC	INC	OT	ICE	✓	x	x	x	x	✓	SSPUC	
	47	Catch tanks, any breather system connected to the PU excluding tubes and hoses	ICE	INC	INC	OT and ICE	ICE	✓	x	x	x	x	✓	LPUC	YES
FUEL SYSTEM	48	Fuel cell including fuel bag, internal baffles/foam, fixings	EXC	EXC	EXC	EXC	EXC							App C6 [6C]	
	49	Lift pump(s) and filter(s)	EXC	EXC	EXC	EXC	EXC							App C6 [6B]	
	50	Collector including any NRVs, pressure sensors, level sensors, fill/drain ports, PRVs, running bleeds, filters, FIA sample tube	EXC	EXC	EXC	EXC	EXC							App C6 [6A]	
	51	Primer pump(s)	EXC	EXC	EXC	EXC	EXC							App C6 [6B]	

PU Area	Item No	List of PU functions/ systems/ components	PU ELEMENT	SEALED PERIMETER	SUPPLY PERIMETER	REFERENCE VOLUME	PU MASS GROUP	UPGRADE SCHEDULE (HOMOLOGATION STATUS)						COMPONENT CLASSIFICATION	ANCILLARY COMPONENTS
								2026	2027	2028	2029	2030	ADUO		
	52	Pressure and temperature sensors at inlet and outlet of FFM and at inlet of high pressure fuel pump	EXC	EXC	EXC	EXC	EXC							App C6 [6F]	
	53	FFM (regulatory fuel flow meter)	EXC	EXC	EXC	EXC	EXC							App C6 [10B]	
	54	Breakaway valves and any filters	EXC	EXC	EXC	EXC	EXC							App C6 [6E]	
ICE COOLERS	55	Secondary heat exchangers for water and oil plus any associated accessories, header tanks, connections to the ICE, tubes, pipes, hoses, and fixings	EXC	EXC	EXC	EXC	EXC							App C6 [9D]	
	56	Primary heat exchangers for water, oil and any associated accessories, header tanks, connections to the ICE, tubes, pipes, hoses, and fixings	EXC	EXC	EXC	EXC	EXC							App C6 [9C]	
	57	ICE intake air heat exchangers and their associated accessories (including but not limited to housings, supports, brackets, fasteners and maximum 2 simple and smooth bore outlet tubes for intake air lines)	EXC	EXC	EXC	EXC	EXC							App C6 [9D or 9E]	
ERS COOLING	58	ICE-mounted ERS cooling system including pumps, associated motors, actuators, excluding tubes, and hoses	PU-CE	INC	INC	ICE and/or ERS	ICE	✓	x	✓	x	✓	✓	LPUC	YES
	59	Non ICE-mounted ERS cooling system including pumps, associated motors, actuators, excluding tubes and hoses	PU-CE	INC	INC	ICE and/or ERS	ESME	✓	x	✓	x	✓	✓	LPUC	YES
	60	Primary and Secondary heat exchangers for ERS cooling fluid plus any associated accessories, header tanks, tubes, pipes, hoses, and fixings connecting to items 34, 58, 59	EXC	EXC	EXC	EXC	EXC							App C6 [3C]	

PU Area	Item No	List of PU functions/ systems/ components	PU ELEMENT	SEALED PERIMETER	SUPPLY PERIMETER	REFERENCE VOLUME	PU MASS GROUP	UPGRADE SCHEDULE (HOMOLOGATION STATUS)						COMPONENT CLASSIFICATION	ANCILLARY COMPONENTS
								2026	2027	2028	2029	2030	ADUO		
	61	ICE-mounted ERS cooling system filters	PU-CE	EXC	INC	ICE	ICE	✓	✓	✓	✓	✓	✓	LPUC	
CLUTCH	62	Clutch and clutch actuation system between the PU and the gearbox	EXC	EXC	EXC	EXC	EXC							App C6 [3D]	
HYDRAULICS	63	ICE-mounted hydraulic pump including associated brackets, fixings, tubes and hoses	EXC	EXC	EXC	EXC	EXC							App C6 [7A]	
	64	Hydraulic system servo valve(s), manifold and hoses for PU control.	ICE	INC	INC	EXC	ICE	✓	x	x	x	x	✓	LPUC	YES
	65	Hydraulic system actuator(s) for PU control	ICE	INC	INC	ICE	ICE	✓	x	x	x	x	✓	LPUC	YES
	66	Hydraulic system (e.g., accumulators, manifolds, servo-valves, solenoids, actuators, hoses) other than servo-valve(s) and actuator(s) for PU control components included in items 64 and 65.	EXC	EXC	EXC	EXC	EXC							App C6 [7A, 7B or 7C]	
	67	ICE-mounted hydraulic circuit filters	ICE	EXC	INC	EXC	ICE	✓	✓	✓	✓	✓	✓	LPUC	
INSTALLATION AND MISCELLANEOUS	68	Fuel feed pumps delivering less than 10 barG and their associated accessories (included but not limited to tubes, hoses, supports, brackets, and fasteners).	EXC	EXC	EXC	EXC	EXC							App C6 [6B]	
	69	Heat Shields and associated mounting hardware.	EXC	EXC	EXC	EXC	EXC							App C6 [10J]	
	70	PU air valve regulators	ICE	EXC	INC	EXC	ICE	✓	✓	✓	✓	✓	✓	LPUC	
	71	Any ancillary equipment associated with the PU air valve system excluding regulators (e.g., pneumatic bottles, hoses, filling valves).	ICE	EXC	INC	EXC	ICE	✓	✓	✓	✓	✓	✓	LPUC	
	72	Intake upstream of compressor inlet/VG Intake device up to and including the air filter.	EXC	EXC	EXC	EXC	EXC							App C6 [10H]	
	73	Exhaust beyond turbine exit and WG exit and associated brackets,	EXC	EXC	EXC	EXC	EXC							App C6 [10F]	

PU Area	Item No	List of PU functions/ systems/ components	PU ELEMENT	SEALED PERIMETER	SUPPLY PERIMETER	REFERENCE VOLUME	PU MASS GROUP	UPGRADE SCHEDULE (HOMOLOGATION STATUS)						COMPONENT CLASSIFICATION	ANCILLARY COMPONENTS
								2026	2027	2028	2029	2030	ADUO		
		support, screws, nuts, dowels, washers, or cables.													
	74	Any breather system ducting between the PU and the orifice referenced in C5.1.9.10	EXC	EXC	EXC	EXC	EXC							App C6 [10K]	
	75	Wiring harnesses attached to the PU which are not ordinarily part of a power unit (car looms)	EXC	EXC	EXC	EXC	EXC							App C6 [11B]	
	76	Studs used to mount PU to the Survival Cell or gearbox.	EXC	EXC	EXC	EXC	EXC							App C6 [10D]	
	77	Boost pressure measurement devices	EX ICE	EXC	INC	EXC	EXC	✓	✗	✗	✗	✗	✗	SSPUC	
	78	Lambda Sensor(s)	EX EXH	EXC	INC	EXC	EXC	✓	✓	✗	✓	✗	✓	DSPUC	
FLUIDS	79	Fuel	EXC	EXC	EXC	EXC	EXC	✓	✓	✗	✓	✗	✓		
	80	Engine oil	EXC	EXC	EXC	EXC	EXC	✓	✓	✗	✓	✗	✓		
	81	Hydraulic fluid	EXC	EXC	EXC	EXC	EXC	✓	✓	✓	✓	✓	✓		
	82	Engine Coolant	EXC	EXC	EXC	EXC	EXC	✓	✓	✓	✓	✓	✓		
	83	ERS Fluid	EXC	EXC	EXC	EXC	EXC	✓	✓	✓	✓	✓	✓		
BALLAST	84	ICE Ballast (subject to Article C4.4)	ICE	INC	INC	ICE	ICE	✓	✓	✓	✓	✓	✓	LPUC	

Column 14 refers to items that may be upgraded as described in Appendix 4, Article 4 – Additional Development and Upgrade Opportunities. A tick in a green cell indicates that the item may be upgraded if the PU Manufacturer is granted ADUO status. A cross in a red cell indicates that no upgrade is permitted even if the PU Manufacturer is granted ADUO status.

Column 15, ‘Component Classification’ identifies which classification of components the item belongs to.

PU **component classifications** are described in Article C18 and any item so regulated will be shown as one of the four PU **component classifications** (LPUC, SSPUC, OSPUC or DSPUC).

For those items associated with a car, the table will show ‘App C6’ referring to Appendix C6

Column 16, ‘Ancillary Components’ identifies those items which are considered as **Ancillaries**, included in the sealed perimeter, and which are subject to the provisions of Article B8.2.4.

Any other non-listed ancillary parts, considered minor but which are necessary for the assembly and normal operation of the **Power Unit**, must be considered as belonging to the main component they are attached to. As such, they benefit from the same category allocations except for the sealed

perimeter from which they are excluded. Such parts are typically mountings, brackets, fixings, tubes, hoses, screws, bolts, studs, shims, nuts, washers, gaskets, O-rings and other seals. It is accepted that such parts can cross the boundaries between 2 reference volumes when they create a link between components belonging to these 2 volumes.

Table 1: Power Unit Components

Table 2: ‘Additional Power Unit matters affecting the Supply Perimeter’ below relates to additional *PU* functions, systems and components not included within the *PU* component definition defined in Table 1 and classifies them as included in or excluded from the Supply Perimeter.

Column 1 provides a description of the general area of the *PU* – in this case Operational matters and is for reference only.

Column 2, ‘Item No’ provides a continuation of the sequential item number from Table 1 for ease of navigation within the table and is for reference only.

Column 3, ‘List of PU functions/systems/components’ provides a description of the functions, systems and components in enough detail to differentiate what is included in or excluded from the Supply Perimeter.

place any aspect of the *PU* supply described into one of the columns. The understanding of what each of the elements listed refers to will be taken as that which is widely understood unless there are specific definitions elsewhere in the regulations. For these items, the definition will take precedence.

Column 4, ‘Supply Perimeter’ differentiates those items included in the *PU* supply *within Power Unit* Maximum Supply Price described in Tech Regs Appendix C5 Article 1.4. ‘INC’ is included in the Supply Perimeter and ‘EXC’ is excluded from the Supply Perimeter.

Table 2: Additional Power Unit matters affecting the Supply Perimeter

	Item No	List of PU functions/ systems/components	SUPPLY PERIMETER
Operational	85	PU and spares for all Competitions in F1 World Championship plus 5000 km testing.	INC
	86	Minimum number of PUs per team to be (number of PUs per driver per season according to Section B of the F1 Regulations) x 2 + Necessary number of units to achieve 5000 km of testing.	INC
	87	Additional PUs or spares required to replace units out of service due to accident damage or other cause induced by team will be outside the supply perimeter and will incur additional charges	EXC
	88	Demo event Power Units	EXC
	89	Transport of Power Units and support equipment from Manufacturer’s factory to event	EXC
	90	Personnel to support Power Unit (5 people per F1 Team) at test and race events	INC

91	Travel, accommodation, and reasonable expenses for support personnel	EXC
92	Quantity of manufacturer specified fuel and oil	EXC
93	Garage equipment defined as compulsory by Manufacturer (e.g., battery management)	INC
94	Garage IT equipment, connection to factory, servers, telemetry, radio, team clothing	EXC
95	Dyno testing of installation components (Y hours or km)	EXC

APPENDIX C5: HOMOLOGATION AND DEVELOPMENT OF POWER UNITS, FUEL AND OIL FOR 2026-2030

Advisory Committee: PUAC

Governance: PU Manufacturers' Governance Agreement / WMSC

1 Homologation dossier

- 1.1 Any PU Manufacturer registered in accordance with the procedures set out in Article 1 of Appendix 5 to supply **Power Units** for use by one or more **F1 Teams** in the 2026 to 2030 Championships must submit to the FIA a **Power Unit** homologation dossier before 1 March of the first year in which it intends to supply such **power unit** for use during the Championship period indicated. Each PU Manufacturer shall be permitted to present only one homologation dossier with respect to the period and the homologation granted will be valid until the end of the 2030 Championship.
- 1.2 The homologation dossier must:
- include details of all the parts described as “**ICE**”, “**PU-CE**”, “**EXH**”, “**TC**”, “**ES**” and “**MGU-K**” in the “**PU ELEMENT**” column of Appendix C4.
 - include a detailed list of all minor parts associated with ancillary components (as described in Appendix C4) which may be replaced when those components are fitted, removed or swapped between **Power Units**. This list must be approved by the FIA.
 - include all documents required in Article 1 of this Appendix.
 - be submitted and updated according to the procedure detailed in the document **FIA-F1-DOC-Cxxx**.
- 1.3 A **Power Unit** will be homologated for an **F1 Team** once a complete homologation dossier has been submitted by the relevant **Power Unit Manufacturer** and has been approved by the FIA, such approval to take place within 14 days from the submission of the homologation dossier.
- 1.4 Each **Power Unit Manufacturer** must submit one homologation dossier which applies to all **F1 Teams** it intends to supply. Only the fuel specification, the engine oil specification, the parts defined in item ~~7069~~ and ~~710~~ of Appendix C4 and **Power Unit** wirings may differ between **F1 Teams**. In this event they must be declared separately in the dedicated sections of the homologation dossier.
- All **Power Units** supplied by a single **Power Unit** Manufacturer must also be operated in the same way, they must therefore be:
- Identical according to the dossier for each **F1 Team**.
 - Run with identical software for PU control and capable of being operated in precisely the same way.
 - Run with identical specifications of engine oil and fuel, and associated software calibrations, unless an alternative supplier is preferred by a **Customer Team**.
- 1.5 **PU Manufacturers** carrying out modifications to the homologated **Power Unit** under the provisions of Article 3 of this Appendix must submit to the FIA an updated homologation dossier at least 14 days before the first introduction of the requested modifications in a **Competition**. The homologation dossier thus submitted:
- Will not constitute a new dossier but will instead be considered as updates to the initial dossier

- b. Must have a clear indication of version number, and all the new changes appropriately highlighted.

1.6 A preliminary dossier must be submitted before 1 November of the year preceding the year of introduction for parts listed in the document FIA-F1-DOC-Cxxx.

2 Information provided by the PU Manufacturer to their customer F1 Teams

Any PU Manufacturer intending to supply a **Power Unit** to an **F1 Team** during a Championship (year N) must:

- a. Declare to the FIA, before 1 August of year N-1, that they provided to their customer **F1 Teams**:
 - i. An initial full external space model of the **Power Unit** including details and locations of all physical interfaces required by the team to install the **Power Unit**.
 - ii. Preliminary estimates of important operating parameters such as heat rejection, fuel mass and density, clutch shaft stiffness and engine stiffness.
- b. Declare to the FIA, before 1 November of year N-1, that they provided to their customer **F1 Teams**:
 - i. A final full external space model of the **Power Unit** including details and locations of all physical interfaces required by the team to install the **Power Unit**.
 - ii. Firm predictions of important operating parameters such as heat rejection, fuel mass and density, **clutch** shaft stiffness and engine stiffness.
 - iii. Initial details of any other parts, procedures, operating conditions and limits or any other information required by the team to install and operate the **Power Unit** as intended.

After the 1 August of year N-1, any significant change compared to previous communication, must be notified to the customer **F1 Teams** in due time. Should a **Customer Team** consider that the change has an unreasonable impact on the **Power Unit** installation in the car, they may contact the FIA within 7 days of the notification. The FIA will then contact the relevant PU Manufacturer and its customer **F1 Teams** in order to conduct its investigation. If the FIA is satisfied, in its absolute discretion, that these changes are acceptable, the FIA will confirm to the PU Manufacturer and the customer **F1 Teams** within 14 days that they may be carried out.

3 Permitted upgrades for the Power Unit

- 3.1** Following the first homologation of a **Power Unit** by a PU Manufacturer in the period 2026-2030, upgrades to **Power Unit** components may only be carried out if they are specifically covered by the provisions of this Article 3.
- 3.2** For the years 2027, 2028, 2029 and 2030, upgrades to the components marked with a “✓” in the table of Appendix 3, in the relevant column for each year, may be carried out. Such upgrades must be introduced for the first **Competition** of the year when they are allowed and used for the whole Championship season.

- 3.3 PU Manufacturers who fulfil the criteria described by Article 4 of this Appendix in year N, will be permitted **one additional specification upgrade in year N+1 for the components marked with a “✓” in the column “ADUO” in the table of Appendix 3 from the first *Competition* in year N+1 on top of any other specification upgrade otherwise permitted. Before 1 March of year N+1, these PU manufacturers must provide the FIA with the schedule for the introduction of all planned “ADUO” specification upgrades and must update it when there are any changes.**
- 3.4 Components may be modified in order to comply with an amendment to the published regulations or issued FIA guidance. Such modifications must be first approved by the FIA.
- 3.5 Minimal incidental changes may be carried out for car installation purposes to the following components of the **Power Unit**, subject to the approval process outlined in Article 3.10.a of this Appendix:
- Wirings
 - Exhaust system, provided the key defining parameters of the system (diameters, lengths, etc.) remain fundamentally unchanged
 - Turbo-compressor position (within 20mm from the original position in relation to the **ICE**), turbo clocking, turbo supports
 - Position of the **wastegates** with housings and pipes
 - Position of the **pop-off valves** with housings and pipes
 - Engine intake air system as defined in item 6 of Appendix C4, provided the key defining parameters of the system (diameters, lengths, etc.) remain fundamentally unchanged
 - Hoses defined in item 71~~9~~ of Appendix C4
- 3.6 Modifications may be made to **Power Unit** components for the sole purposes of reliability, safety, cost saving, or supply issues, subject to the approval process outlined in Article 3.10.a of this Appendix.
- 3.7 Minor modifications may be made to **Power Unit** components subject to the approval process outlined in Article 3.10.a of this Appendix. Such modifications may be (but are not limited to) due to different branding, a change of supplier, a change of part number, etc. and may have no or very limited effect on reliability or functionality.
- 3.8 Requests for repair of a **Power Unit** component in the form of a patch made of the same material or of a composite material, following damage or failure, may be accepted if it is only local and minimal. If accepted, such repair can be applied on a temporary basis to all components available. If the repair is made of a different material, such a repair must not be present on the components used during the following Championship season.
- 3.9 Changes of fuel and oil suppliers will be accepted, provided such changes are intended for commercial and not for performance reasons.
- 3.10 The following additional constraints apply to the permitted modifications discussed in this Article 3:
- To carry out modifications under the provisions of Articles 3.5, 3.6 and 3.7 of this Appendix, PU Manufacturers must apply in writing to the FIA Technical Department and must provide all

necessary supporting information including, where appropriate, clear evidence of failures. The FIA will circulate the correspondence to all **Power Unit** Manufacturers for comment. If the FIA is satisfied, in its absolute discretion, that these changes are acceptable, they will confirm to the **Power Unit** Manufacturer concerned that they may be carried out.

Wherever practical, such requests must be submitted at least 14 days before the requested date of homologation.

The procedure and associated document templates that must be used by the **Power Unit** Manufacturers for their requests are available in the document [FIA-F1-DOC-Cxxx](#).

- b. Any permitted modifications concerning parts that are inside the sealed perimeter (i.e. parts described as “INC” in the “Sealed Perimeter” column of Appendix C4) can only be applied to new **Power Unit** elements.
- c. With reference to the FIA F1 Regulations - Section B [Sporting], if a **Power Unit** Element is subsequently replaced by another of a different specification between the **Sprint Qualifying Session** and the **Sprint Session** or between the **Qualifying Session** and the **Race**, the replacement **Power Unit** part will be considered the same in design and similar in mass, inertia and function if any differences it contains are limited to components modified under the provisions of Articles 3.6, 3.7 and 3.8 of this Appendix.
- d. A **Customer Team** may refuse or request a delay of a **Power Unit** modified under the provisions of Articles 3.3, 3.6 and 3.7 of this Appendix if such modifications cause installation issues in their car. In such cases, the **Customer Team** must apply in writing to the FIA Technical Department and must provide all necessary supporting information. If the FIA is satisfied, in its absolute discretion, that the installation issues are genuine, they will confirm approval to the **Customer Team** and to the PU Manufacturer. In this case, the provisions of (e) below won't apply.
- e. The first time one or more **Power Units** comprising modified parts, as permitted by Article 3.6 of this Appendix, are used in any of the cars powered by the **Power Unit** Manufacturer, a minimum of 1 **Power Unit** with the exact same specification must be available for each **F1 Team**. Each **F1 Team** will have priority use of one of these **Power Units** until the end of the first day of the **Competition**.

In the case of a Manufacturer supplying **Power Units** to more than 2 **F1 Teams**, one exception per Championship season can be granted by the FIA, in its absolute discretion, in the event of genuine supply issues. The request must be made in writing to the FIA Technical Department and must provide all necessary information and evidence of the supply issue. If the FIA is satisfied, the minimum required number of **Power Units** available for all **F1 Teams** may be reduced to 2 for the Event where the modified part is used for the first time.

- f. Any new **Power Unit** element used for the first time in a **Competition** must always include all modifications included in any **Power Unit** element already used by any of the cars powered by the PU Manufacturer.
- g. The requirements of e. and f. don't apply to minor modifications as defined in 3.7.
- h. A **Power Unit** element will be deemed to have been used once the car's timing transponder has shown that it has left the pit lane.

3.11 Minimal incidental changes may be carried out on PU components as a consequence of changes made to another PU component with a different upgrade schedule. Such modifications are subject to the approval process outlined in Article 3.10.a of this Appendix.

4 Additional Development and Upgrade Opportunities

~~Over the first five~~ During the entire season's **Competitions** of each Championship ~~Season~~ in the 2026-2030 period, the FIA will monitor the performance of Internal Combustion Engine (**ICE**) part of all the **Power Units** supplied by each PU Manufacturer to its customer **F1 Teams**.

For each **ICE** supplied by the PU Manufacturers, an average power will be calculated. The methodology to calculate this power can be found in the document **FIA-F1-DOC-Cxxx**.

Any PU Manufacturer whose **ICE** power is more than 3% below that of the highest **ICE** power recorded amongst all the PU Manufacturers will be granted Additional Development and Upgrade Opportunities ("ADUO") **a week after the 5th Competition in the year. No other ADUO will be granted later during the season.**

PU Manufacturers granted ADUO may implement further upgrades (as described in Article 3.2 of this Appendix) and extend the usage of their PU Test Benches (as described in Article F5).

The FIA reserves the right to:

- a. Revoke the ADUO **at any point after the 5th Competition in the year and the end of the Championship season** if the performance demonstrated by the PU Manufacturer after the first five **Competitions** is inconsistent with that measured during the first five **Competitions**.
- b. Take measures, to its absolute discretion, if the resulting upgrades implemented by the PU Manufacturer under the provisions of Article 3.2 of this Appendix give that PU Manufacturer an advantage that is deemed to be unfair in comparison to PU Manufacturers who were not awarded any ADUO. Such measures will be discussed in good faith with all PU Manufacturers.

5 Conformity with the power unit homologation dossier

All **Power Units** must be delivered such that the seals required under Article B8.2.9 can be fitted. Both the **Power Unit** Manufacturer and users of a homologated **Power Unit** must take whatever steps are required at any time by the FIA Technical Department, in its absolute discretion, to demonstrate that a **Power Unit** used at a **Competition** is in conformity with the corresponding **Power Unit** homologation dossier.

APPENDIX C6: COMPONENTS' CLASSIFICATION AND PERIMETER

Advisory Committee: TAC

Governance: F1 Commission / WMSC

Table 1 - The following table defines the classification, of components for *Formula One* cars and support equipment.

Ref.	Component or Assembly	Art.	Class	Group	System Description, & Boundaries	Included Components (List not exhaustive) & Supply Terms	Excluded Components
1	Survival Cell Items & Safety Structures						
1A	Survival Cell and Primary Roll Structure	C12	LTC	SCL	The structure that includes the cockpit, takes suspension loads and aerodynamic loads and transfers them from and to the FIS through the FIS fixings and power unit through the engine studs plus the roll structure as defined in 12.4.1.	Bonded component as submitted for homologation.	Any additional bonded components not required for FIA tests, any components fitted for FIA tests that are then subsequently removed
1D	Front Floor Structure	C12.2.7	OSCNT	SCL	Front floor assembly	Front floor structure, its mounting brackets, and any device or structure (and their mounting brackets) between the front floor structure and the Survival Cell .	Fairings.
1G	Front Impact structure	C13.6.1	LTC	FWN	The structure that takes aerodynamic loads from the front wing and transfers them to the chassis	FIS, hangers, fixings to chassis that are part of the FIS assembly	Fairings, Camera brackets
1H	Rear Impact structure	C13.7.1	TRC	GBX	The structure that mounts to the rear of the gearbox behind the differential	Part as bonded to gearbox carrier. Details of flange for Rear Wing Beam attachment, excluding profile details.	Fairings, bolted components
1K	Pedals		OSC	BRA	Pedal Assembly	Brake pedal assembly including pushrod connecting to the brake master cylinders(s), throttle Pedal including throttle damper, heel-rest, mounting brackets and local electrical and electronic components	Fixings to the Survival Cell .
1L	Mirror Lens	C12.2.7	OSC	BWK	Mirror Lens	Mirror Lens	Backing structures
1M	Side Impact Structures	C13.5	DSC	SCL	Upper & Lower SIS Tubes	SIS Tubes Supply to be agreed before 30 June year N-1	Mounting Brackets
1N	Halo	C12.4.2	DSC	SCL	Halo, and fixings	Halo, fwd. pin, rwd. bolts.	Fwd, mounting bracket, fairings.

Ref.	Component or Assembly	Art.	Class	Group	System Description, & Boundaries	Included Components (List not exhaustive) & Supply Terms	Excluded Components
						Supply to be agreed before 30 June year N-1	
2	Aerodynamic Components						
2A	Aerodynamic Components, unless otherwise specified	C3	LTC	BWK			
2B	Plank assembly	C3.5.9	LTC	BWK	Plank assembly as defined in 3.5.9	Plank structure and skids	
2C	Rear wing adjuster (SLM)	C3.10.10	OSCNT	RW	SLM actuator including linkages	Machined SLM Actuators, linkages, local electrical and electronic components	Hoses, any component rigidly attached to the rear wing flap.
2D	Front Wing Adjuster (SLM)		OSCNT	FWN			
2E	Rear Wing		LTC	RW			
2F	Front Wing		LTC	FWN			
2G-F	Front Drum		LTC	SFO			
2G-R	Rear Drum		LTC	SRO			
2H-F	Susp Fairings - Front		LTC	SFO			
2H-R	Susp Fairings - Rear		LTC	SRO			
3	Transmission						
3A	Gearbox Case	C9.5	TRC	GBX	As defined in Article 9.1.5	Gearbox carrier, associated fastenings, internal heat shields Front Cover, Diff Cap, Seals, Fasteners, Cross-shaft Covers	RIS, Inboard suspension components, Engine mountings
3C	Clutch	C9.2	TRC	GBX	Rotating clutch assembly and fixings to PU or Gearbox as appropriate.	Clutch basket assembly, Plates, Spring, fixings to PU or Gearbox, Spigot bearing	
3D	Clutch actuation system	C9.2	TRC	GBX	Clutch actuator assembly including sensors and cooling shroud and sensors	Clutch Actuator, Actuator support, local electrical and electronic components, Fixings to PU or Gearbox, Cooling Shroud.	Servo Valves
3E	Clutch shaft	C9.2	TRC	GBX	Shaft between clutch and gearbox (if PU mounted) or PU (if Gearbox mounted)	Clutch shaft, intermediate support bearing and bracket if required.	Clutch shaft torque sensor
3F	Clutch shaft torque sensor	C9.2	SSC	GBX			
3G	Gearbox Internals	C9.5	TRC	GBX	All components involved in transmitting torque between the gearbox input shaft and the drive	Driveline and Gear-change components defined in Article 9.1	Servo valves

Ref.	Component or Assembly	Art.	Class	Group	System Description, & Boundaries	Included Components (List not exhaustive) & Supply Terms	Excluded Components
					shafts and components essential for the functioning of the gearbox.		
3K	Auxiliary Components (Oil system, reverse gear etc.)	C9.5	TRC	GBX	Components that are not included in Driveline or Gear-Change Components but interact directly with these components and are essential for the functioning of the gearbox.	Oil Pressure and Scavenge Pumps, Oil Filter, Oil Tank, Reverse-gear idler & Actuator, Differential Actuator, local electrical and electronic components.	Oil cooler
3L	Drive shaft	C9.10	OSC	GBX	The assembly that transfers load from the gearbox driveline components to the Axles	Driveshaft, joints, bearings and any required fixings, trigger wheels if present	
3M	Drive shaft Torque Sensor	C9.11	OSC	NA			
4	Suspension and Steering						
4A	Inboard Front Suspension	C10.4	TRC	SFI	All parts of the front suspension between the connection to the push / pull rod and the Survival Cell .	Rockers, springs, ARB system, damper, bearings, local electrical and electronic components, ride height adjustment, any brackets which are not integral with the Survival Cell . A range of set-up options	
4B	Front Suspension Members	C10.3	TRC	SFO	Structural members connecting the upright to the Survival Cell , steering or inboard suspension	Wishbones / Links, Track-rod, Push/pull Rod, Bearings, Inboard Brackets not integrated in the Survival Cell , Fasteners, Wheel Tethers, local electrical and electronic components	Suspension Fairings as defined in 3.14
4C	Front Upright Assembly (Excluding Axles, bearings, nuts & retention system)	C10.6	TRC	SFO	Upright assembly between the connection to the suspension members and the wheel bearings	Upright, Brackets – including variants for set-up changes, Fasteners, local electrical and electronic components, Upright Loom.	Any braking system components described in Article 11
4D	Front Axles (Inboard of the contact surface with the wheel		TRC	SFO	Axle geometry lying inboard of the contact surface with the wheel spacers and wheel bearing assembly	Axle geometry lying inboard of the contact surface with the wheel spacers, wheel bearings and spacers, interface	

Ref.	Component or Assembly	Art.	Class	Group	System Description, & Boundaries	Included Components (List not exhaustive) & Supply Terms	Excluded Components
	spacer) and bearings,					and mounting to the brake disc bell.	
4E	Front Axles (outboard of the contact surface with the wheel spacer), nuts & retention system	C10.9	OSC	SFO	Axle geometry lying outboard of the contact surface with the wheel spacers, wheel nut and dual stage mechanism to retain nut if loose	Axle geometry lying outboard of the contact surface with the wheel spacers, axle nuts, wheel nut, fasteners, and wheel nut retention system.	
4F	Inboard Rear Suspension	C10.4	TRC	SRI	All parts of the rear suspension between the connection to the push / pull rod and the gearbox carrier	Rockers, springs, ARB system, dampers, bearings, local electrical and electronic components, ride height adjustment, any brackets which are not integral with the Gearbox Carrier. A range of set-up options	
4G	Rear Suspension Members	C10.3	TRC	SRO	Structural members connecting the upright to the gearbox case or inboard suspension	Wishbones / Links, Track-rod, Push/pull Rod, Bearings, Inboard Brackets not integrated in the Gearbox Carrier, Fasteners, Wheel Tethers, local electrical and electronic components.	Suspension Fairings as defined in 3.14
4H	Rear Upright Assembly (Excluding Axles, bearings, nuts & retention system)	C10.6	TRC	SRO	Upright assembly between the connection to the suspension members and the wheel bearings	Upright, Brackets – including variants for set-up changes, Fasteners, local electrical and electronic components.	Any braking system components described in Article 11
4I	Rear Axles (Inboard of the contact surface with the wheel spacer) and bearings,		TRC	SRO	Axle geometry lying inboard of the contact surface with the wheel spacers and wheel bearing assembly	Axle geometry lying inboard of the contact surface with the wheel spacers, wheel bearings and spacers, interface and mounting to the brake disc bell,	
4J	Rear Axles (outboard of the contact surface with the wheel spacer), nuts & retention system	C10.9	OSC	SRO	Axle geometry lying outboard of the contact surface with the wheel spacers, wheel nut and dual stage mechanism to retain nut if loose	Axle geometry lying outboard of the contact surface with the wheel spacers, axle nuts, wheel nut, fasteners, and wheel nut retention system.	

Ref.	Component or Assembly	Art.	Class	Group	System Description, & Boundaries	Included Components (List not exhaustive) & Supply Terms	Excluded Components
4L	Power Assisted Steering	C10.5.3	TRC	STG	Steering unit from the attachment to the steering column to the clevises for the track rods, connection to the hydraulic system and connection to the electrical loom	Rack assembly, local electrical and electronic components, protective cover, fasteners to Survival Cell , options for varying assistance.	
4M	Steering column	C10.x	OSC	STG	The assembly that transfers load from the steering wheel QD through to the Power Assisted Steering	Forward and Rearward columns, bearings, mounting brackets, attachments to chassis, parts required to pass impact test. local electrical and electronic components.	Fixings to the Survival Cell .
4N	Steering wheel and quick release		OSC	STG	The assembly that transfers load from the driver to the steering column	Steering Wheel, quick release mechanism, gear shift and clutch paddles, local electrical and electronic components, SECU elements integrated in the assembly	Any component that cannot be removed via the operation of the quick release
4P	Wheel rims	C10.7	OSC	WHE	Wheel Rim Assembly	Rim, drive pegs, spacers, closing panels, Tyre valve, TPMS sensor mount.	TPMS sensor
4Q	Tyre pressure sensor (TPMS)		SSC	NA	BF1 TPMS	Mountings	Tyre valve
4R	Tyres	C10.8	SSC	NA			
5	Brakes						
5A	Brake disc, disc Bell, and pad assembly	C11	OSC	BRA		Structural brake disk bell transferring torque from the axle to the brake disc, brake disk and pads	Any component bolted on the structural disk bell (i.e. deflectors)
5B	Brake calipers	C11	OSC	BRA		Machined Brake Calipers, pistons, seals, QD's, local electrical and electronic components	Hoses, pipes, and mounting system to the uprights.
5C	Rear brake control system (BBW)	C12	OSC	BRA		BBW master cylinder and actuator, servo or solenoid valves, directly mounted local electrical and electronic components master cylinders, balance bar assembly	Hoses and pipes
5D	Brake master cylinder	C12	OSC	BRA		Master cylinder(s), push-rods, brake balance system, local	Fixings to the Survival Cell .

Ref.	Component or Assembly	Art.	Class	Group	System Description, & Boundaries	Included Components (List not exhaustive) & Supply Terms	Excluded Components
						electrical and electronic components	
6	Fuel System						
6A	Collector	C6.6.4, C6.6.6	OSC	FSY	Collector assembly and pressurisation system if fitted.	Collector assembly including any pressurisation system, any local electrical and electronic components, level sensor, filters, AV mounts and mounting fasteners	Hoses and pipes
6B	Primer pumps, and flexible pipes and hoses	C6.6.2, C6.6.3	SSC	FSY	Primer pump(s), and pipes between the primer pump(s) and the breakaway valve.	Primer pump(s), flexible pipes and hoses and their fittings between pump(s) and breakaway valve, fuel flow meter inlet pressure and temperature sensors.	Components classified as part of collector. Components upstream of primer pump(s). Components between primer pump(s) and breakaway valve listed as OSC.
6C	Fuel Bladder	C6.1	LTC	FSY			
6D	Fuel system components not listed as OSC or SSC or LTC	C6.2, C6.3, C6.5, C6.6	TRC	FSY			Fuel bladder
6E	Fuel System Hydraulic Layout as described by schematic in article 6.6	C6.6.1, C6.6.3, C6.6.4, C6.6.5, C6.6.6	OSC	FSY	Low pressure fuel system from lift pump inlet filters up to and including chassis breakaway valve or optional inlet filter to high pressure fuel pump (if fitted)	Pressure Relief Valves (PRV), Non-Return Valves (NRV), Breakaway Valve, filters, lift pumps, optional damper, rigid pipes and manifolds and their fittings, FIA sample, collector fill/drain port, optional collector pressure sensor, optional running bleed Any additional parts which are not shown on the schematic, but which will be deemed to be necessary for the proper behaviour of the hydraulic circuit shown in the schematic, subject to the approval of the FIA Technical Department	Fuel cell pressurisation system. Fuel cell fill/drain, and vent. Primer pump(s), flexible pipes and hoses and their fittings, fuel flow meters and their inlet pressure and temperature sensors
6F	Fuel tank pressure sensor and PRV	C6.1.4 C6.6.4	LTC	FSY	The Sensor and PRV specified in 6.1.4 and shown in diagram 6.6.4	Sensor and fittings to fuel bladder. PRV and fittings to fuel bladder	Fuel bladder

Ref.	Component or Assembly	Art.	Class	Group	System Description, & Boundaries	Included Components (List not exhaustive) & Supply Terms	Excluded Components
7	Hydraulic System						
7A	Hydraulic pump and accumulator		TRC	HYD		Hydraulic pump, hydraulic accumulator, local electrical and electronic components, parts required to mount the unit to the PU	
7B	Hydraulic manifold, sensors & control valves		TRC	HYD		Hydraulic manifold block, servo valves, solenoid valves, filters, local electrical and electronic components, AV mounts.	
7C	Pipes between hydraulic pump, hydraulic manifold & gearbox or engine actuators		TRC	HYD		Pipes, fittings, QD connectors.	Pipes to/from cooler, pipes to/from actuators not associated with gearbox, PU (BBW, PAS etc).
9	Oil & Coolant Systems						
9C	Primary heat exchangers	C7.4.1b	LTC	HEX	Heat exchanger assembly as defined in 7.4.1b	Welded cooler, electrical and electronic components directly fitted to cooler	Fittings, hoses, pipes, AV mounts
9D	Secondary heat exchangers	C7.4.1c	TRC	HEX	Secondary heat exchanger units as defined in 7.4.1c	Heat exchanger unit, directly mounted electrical and electronic components	Ducts feeding cooling air, pipes, hoses, AV mounts.
10	Power Unit Ancillaries and Sensors						
10A	ES IVT sensor	C5.	SSPUC	NA			
10B	Fuel Flow Meter	C5.9.3	SSC	NA	Prescribed fuel flow meters		Fittings, hoses, pipes, AV mounts
10C	Power Unit Pressure and Temperature sensors	C5.	SSPUC	NA			
10D	Power Unit mountings to gearbox and Survival Cell	C5.4.17	TRC	ENG	Studs between PU and Survival Cell and between PU and Gearbox.	Studs, Nuts, Top-hat Bushes, Barrel nuts.	ds integrated into Survival Cell or gearbox carrier
10E	High Pressure fuel pump	C5.11.6	SSPUC	NA			
10F	Exhaust System Beyond Turbine and Wastegate Exits	C3.8.2	TRC	ENG	Exhaust and wastegate pipes downstream of turbine exit / wastegate exit.	Pipes, clamps	

Ref.	Component or Assembly	Art.	Class	Group	System Description, & Boundaries	Included Components (List not exhaustive) & Supply Terms	Excluded Components
10G	Air Filter		FSC	ENG			Components inside the Power Unit Supply Perimeter
10H	Compressor Inlet Duct	Apx.C4 Table 1 #71	FSC	ENG			Components inside the Power Unit Supply Perimeter
10J	Engine Heat Shields	Apx.C4 Table 1 #68	FSC	ENG			Components inside the Power Unit Supply Perimeter
10K	Breather System	Apx.C4 Table 1 #73	LTC	ENG	As defined in App.C4		Components inside the Power Unit Supply Perimeter.
11	Electrical Systems Hardware						
11B	Electrical looms		TRC	ELE	Looms interfacing the main chassis electrical system with PU systems, transmission systems and other peripheral control or measurement systems.	Main chassis looms, can be made of separate parts, up to and including the connectors to local PU looms, transmission looms or other local looms for peripheral control or measurement systems.	Looms for test installations linked to Article 8.15.1
11C	car to team telemetry	C8.5.1	SSC	NA			
11D	Driver radio	C8.8	SSC	NA			
11E	Accident Data Recorder (ADR)	C8.9.1	SSC	NA			
11F	High speed camera	C8.9.3	SSC	AN			
11G	In-ear accelerometers	C8.9.4	SSC	NA			
11H	Biometric devices	C8.9.5	SSC	NA			
11J	Marshalling system	C8.11	SSC	NA			
11K	Timing Transponders	C8.15	SSC	NA			
11L	TV Cameras	C8.16	SSC	NA			
11S	Standard Electronic Control Unit (SECU)		SSC	NA			
11T	SECU FIA applications		SSC	NA			
11U	SECU Team applications		LTC	NA			
12	Safety Equipment						
12B	Rear lights	C14.3	SSC	NA			Local electrical looms
12C	Driver Cooling System	C14.6	OSC	NA	Driver cooling system up to the connector to the	All components declared under Article 4.7.b.ii.	Driver's personal equipment.

Ref.	Component or Assembly	Art.	Class	Group	System Description, & Boundaries	Included Components (List not exhaustive) & Supply Terms	Excluded Components
					driver's personal equipment.		Pipe runs between sub-assemblies.
13	Miscellaneous Components						
14	Pitstop Equipment						
14A	Wheel Guns		FSC	PSE	The impact wrenches used to remove and fasten wheels during a pit stop. Either pneumatically, or electrically powered	Guns, Air lines (between gun and gantry for pneumatic), Batteries (if electrical), signalling lights, signal cables, calibration jig, Heatshields (for protecting guns in extreme weather conditions)	
14B	Front Jack		FSC	PSE	The jack used to lift the front of the car.	Jack, signalling lights, signal cables.	Cradle shaped to any LTC component.
14C	Rear Jack		FSC	PSE	The jack used to lift the rear of the car.	Jack, signalling lights, signal cables.	Cradle shaped to any LTC component.
14D	Side Jack		FSC	PSE	Jack inserted from the side in unusual situations	Jack	
14E	Overhead Gantry		FSC	PSE	Gantry or gantries providing air and electrical connections to other items of pitstop equipment.	Gantry, air lines, air regulators, cabling.	
14F	Control System		FSC	PSE	The system used to control the pit-stop	Sensors, cameras, "traffic lights", associated cabling, software.	
14G	Transport Boxes		FSC	PSE	Boxes and stillages used to transport pitstop equipment	Boxes, stillages.	

Table 2 – Components sorted by Group

Group	Ref.	Component or Assembly	Art.	Class
BRA	Brakes			
BRA	1K	Pedals		OSC
BRA	5A	Brake disc, disc Bell, and pad assembly	C11	OSC
BRA	5B	Brake calipers	C11	OSC
BRA	5C	Rear brake control system (BBW)	C12	OSC
BRA	5D	Brake master cylinder	C12	OSC

Group	Ref.	Component or Assembly	Art.	Class
BWK	Bodywork			
BWK	1L	Mirror Lens	C12.2.7	OSC
BWK	2A	Aerodynamic Components, unless otherwise specified	C3	LTC
BWK	2B	Plank assembly	C3.5.9	LTC
ELE	Electrical			
ELE	11B	Electrical looms		TRC
ENG	Engine Accessories			
ENG	10D	Power Unit mountings to gearbox and Survival Cell	C5.4.17	TRC
ENG	10F	Exhaust System Beyond Turbine and Wastegate Exits	C3.8.2	TRC
ENG	10G	Air Filter		FSC
ENG	10H	Compressor Inlet Duct	Apx.C4 Table 1 #71	FSC
ENG	10J	Engine Heat Shields	Apx.C4 Table 1 #68	FSC
ENG	10K	Breather System	Apx.C4 Table 1 #73	LTC
FUS	Fuel System			
FUS	6A	Collector	C6.6.4, C6.6.6	OSC
FUS	6C	Fuel Bladder	C6.1	LTC
FUS	6D	Fuel system components not listed as OSC or SSC or LTC	C6.2, C6.3, C6.5, C6.6	TRC
FUS	6E	Fuel System Hydraulic Layout as described by schematic in article 6.6	C6.6.1, C6.6.3, C6.6.4, C6.6.5, C6.6.6	OSC
FUS	6F	Fuel tank pressure sensor and PRV	C6.1.4 C6.6.4	LTC
FWN	Front Wing & Nose			
FWN	1G	Front Impact structure	C13.6.1	LTC
FWN	2D	Front Wing Adjuster (SLM)		OSCNT
FWN	2F	Front Wing		LTC
GBX	Gearbox			
GBX	1H	Rear Impact structure	C13.7.1	TRC
GBX	3A	Gearbox Case	C9.5	TRC
GBX	3C	Clutch	C9.2	TRC
GBX	3D	Clutch actuation system	C9.2	TRC

Group	Ref.	Component or Assembly	Art.	Class
GBX	3E	Clutch shaft	C9.2	TRC
GBX	3G	Gearbox Internals	C9.5	TRC
GBX	3K	Auxiliary Components (Oil system, reverse gear etc.)	C9.5	TRC
GBX	3L	Drive shaft	C9.10	OSC
HEX	Heat Exchangers			
HEX	9C	Primary heat exchangers	C7.4.1b	LTC
HEX	9D	Secondary heat exchangers	C7.4.1c	TRC
HYD	Hydraulic System			
HYD	7A	Hydraulic pump and accumulator		TRC
HYD	7B	Hydraulic manifold, sensors & control valves		TRC
HYD	7C	Pipes between hydraulic pump, hydraulic manifold & gearbox or engine actuators		TRC
PSE	Pit Stop Equipment			
PSE	14A	Wheel Guns		FSC
PSE	14B	Front Jack		FSC
PSE	14C	Rear Jack		FSC
PSE	14D	Side Jack		FSC
PSE	14E	Overhead Gantry		FSC
PSE	14F	Control System		FSC
PSE	14G	Transport Boxes		FSC
RW	Rear Wing			
RW	2C	Rear wing adjuster (SLM)	C3.10.10	OSCNT
RW	2E	Rear Wing		LTC
SCL	Survival Cell			
SCL	1A	Survival Cell and Primary Roll Structure	C12	LTC
SCL	1D	Front Floor Structure	C12.2.7	OSCNT
SCL	1M	Side Impact Structures	C13.5	DSC
SCL	1N	Halo	C12.4.2	DSC
SFI	Inboard Front Suspension			
SFI	4A	Inboard Front Suspension	C10.4	TRC
SFO	Outboard Front Suspension			
SFO	2G-F	Front Drum		LTC
SFO	2H-F	Suspension Fairings - F		LTC

Group	Ref.	Component or Assembly	Art.	Class
SFO	4B	Front Suspension Members	C10.3	TRC
SFO	4C	Front Upright Assembly (Excluding Axles, bearings, nuts & retention system)	C10.6	TRC
SFO	4D	Front Axles (Inboard of the contact surface with the wheel spacer) and bearings,		TRC
SFO	4E	Front Axles (outboard of the contact surface with the wheel spacer), nuts & retention system	C10.9	OSC
SRI	Inboard Rear Suspension			
SRI	4F	Inboard Rear Suspension	C10.4	TRC
SRO	Outboard Rear Suspension			
SRO	2H-R	Rear Drum		LTC
SRO	2I-R	Suspension Fairings - Rear		LTC
SRO	4G	Rear Suspension Members	C10.3	TRC
SRO	4H	Rear Upright Assembly (Excluding Axles, bearings, nuts & retention system)	C10.6	TRC
SRO	4I	Rear Axles (Inboard of the contact surface with the wheel spacer) and bearings,		TRC
SRO	4J	Rear Axles (outboard of the contact surface with the wheel spacer), nuts & retention system	C10.9	OSC
STG	Steering System			
STG	4L	Power Assisted Steering	C10.5.3	TRC
STG	4M	Steering column	C10.x	OSC
STG	4N	Steering wheel and quick release		OSC
WHE	Wheels			
WHE	4P	Wheel rims	C10.7	OSC

APPENDIX C7: APPROVED CHANGES FOR FUTURE YEARS

Changes Approved for 2027

13.6.2 Front Impact Structure Homologation

~~Two identical~~ One **FIS**s must be presented for homologation. ~~By random selection by the FIA on the day of the homologation, this FIS will be subject to either;~~

- i. ~~One will be subject to~~ The push-off tests described in Articles C13.6.3.a and C13.6.3.b followed by dynamic test described in Article C13.6.5.

~~and or~~

- ii. ~~The second will be subject to~~ The push-off test described in Article C13.6.3.c followed by the dynamic test described in Article C13.6.6.

~~In the case where a dynamic test did not meet the acceleration requirements, at the discretion of the FIA, the Competitor may be permitted to repeat only the failed test.~~

C5.17.4 All cars must be fitted with one ERS Status Buzzer unit which:

- a. Have been supplied by an FIA designated manufacturer and fitted to the car in accordance with the instructions in the Appendix to the Technical and Sporting Regulation.
- b. Are in working order throughout the **Competition**.
- c. Remains powered for at least 15 minutes following the start of the shutdown process. The **FIA ADR** internal battery will be responsible for the power supply to the unit once the ERS is shutdown.

C5.17.5 All cars must provide signals regarding the current car operating safety status to the **FIA ADR** in order to facilitate control of the ERS status lights and **ERS Status Buzzer unit**. The status of the car must be based at least on the insulation measurement, cells voltage, cells temperature, contactors and the systems defined in C5.23.4.

The below is to be rediscussed in TAC once governance is in place.

C3.17.3 The surface bounded by the external cross-section of each **Suspension Fairing**, when taken normal to the corresponding suspension member's load line defined in Article C10.3.6 (a) must:

- a. intersect the load line, except for front suspension elements, locally, for the sole purpose of ensuring minimum clearance with the **Wheel Rim** at full steering lock.
- b. have at least one axis of symmetry where the larger one will be called the "major axis."
- c. have no dimension which exceeds:
 - i. 100mm.
 - ii. 5mm larger than the major axis.
- d. have an aspect ratio no greater than 3.5:1, where aspect ratio is the ratio of the major axis to the maximum thickness, measured in the direction normal to the major axis.
- ~~e. have an incidence (defined as the angle between the major axis and the plane Z=0 with the car at its legality ride height, as defined in Article C10.1) which lies within the following ranges:~~
 - ~~i. For Front **Suspension Fairings**, between 10deg (nose down) and 0deg.~~

~~ii For Rear **Suspension Fairings**, between 10deg (nose down) and -10deg (nose up):~~

Each **Suspension Fairing** must have a 'fairing symmetry surface', formed by connecting every adjacent major axis along its length. Considering each fairing symmetry surface independently:

- e. the section formed when intersected with any Y-Plane, must have an incidence which lies between 10deg (nose down) and -10deg (nose up). Such an incidence is defined as the angle between a line tangent to any part of the section and Z=0 with the car at its legality ride height, as defined in Article C10.1.

Changes Approved for 2028

APPENDIX C8: SUPPLY OF POWER UNITS, FUEL AND OIL FOR 2026-2030*Advisory Committee: PUAC**Governance: PU Manufacturers' Governance Agreement / WMSC**Will be moved to Section A of the Regulations when that Section is published***1 Supply of Power Units for the 2026 to 2030 FIA Formula 1 World Championship****1.1 Registration Requirement and Effect for Power Unit Manufacturers**

1.1.1 Any entity that wishes to supply **Power Units** (“PUs”) to one or more Competitors (including a Competitor that is the same legal entity as the supplier or that is affiliated to the supplier) (a “**PU Manufacturer**”) for use in one or more editions of the Championship taking place in seasons 2026 to 2030 must complete the PU Manufacturer registration form, enter into the PU Manufacturer Non-Assert Agreement (as defined in Article 3 below) and also enter into the “2026 F1 PU Governance Agreement”.

1.1.2 The deadline for a PU Manufacturer wishing to supply **Power Units** starting from year N in this period to complete the PU Manufacturer registration form will be: (a) 30 June of year N-4; (b) 30 days after the publication of the first set of 2026 PU Technical, Sporting and Financial Regulations; (c) 15 October 2022, whichever is the later.

1.1.3 The acceptance (or otherwise) by the FIA of a PU Manufacturer registration form and any confirmation of registration will be at the sole discretion of the FIA. The FIA also reserves the right, at its sole discretion, to accept the registration of a PU Manufacturer who has failed to comply with the deadline defined in Article 1.1.2 of this Appendix. A PU Manufacturer whose registration is accepted notwithstanding its failure to meet the deadline set out at Article 1.1.2 of this Appendix must comply with the requirements of Article 1.1.1 of this Appendix, and additionally demonstrate to the FIA that the failure to comply with of any aspects of the registration process defined in this Appendix has not led to that PU Manufacturer obtaining any competitive or financial advantage over any other PU Manufacturer. The FIA will review any such information provided at its sole discretion.

1.1.4 Notwithstanding any confirmation of registration provided by the FIA, the registration of a PU Manufacturer will only be complete (and so will only become valid and effective) upon the applicant’s payment to the FIA of the applicable administrative fee and its entry into the PU Manufacturer Non-Assert Agreement and the 2026 F1 PU Governance Agreement.

1.2 Obligations related to the supply of Power Units to a Competitor for the year N

1.2.1 Each PU Manufacturer of a homologated PU must provide the FIA, before 15 May of year N-1, with the list of Competitors (clearly identifying the appointed “works/factory” Competitor (also referred to as the “Nominated Competitor”)) with which it has concluded a supply agreement for the given Championship season N.

Save for exceptional circumstances, as determined in the FIA’s absolute discretion, the appointed works / factory Competitor must be identified using the following criteria:

- a. If the PU Manufacturer supplies only one Competitor, and/or if only one Competitor belongs to the Legal Group Structure of the PU Manufacturer, then that Competitor will be the works / factory Competitor; or

- b. If the criteria of point (a) do not apply, the works / factory Competitor will be the Competitor who earned the highest Constructors Championship finishing position in the Championship season N-2.

1.2.2 A PU Manufacturer, if called upon to do so by the FIA before 1 June of year N-1, must supply at least a number of Competitors (“T”) equal to the following equation:

$T = (N_{TOT} - A) / (B - C)$, where:

T is rounded up to the next whole integer

A = Total number of Competitors (including “works/factory” Competitors) having a supply agreement concluded for year N with a New PU Manufacturer.

B = Total number of manufacturers of homologated PUs for year N.

C = Total number of New PU Manufacturers for year N.

N_{TOT} = is set to 11 and is related to the “total number of entered Competitors” for year N, which is not known until November of year N-1. This number may be reviewed if the number of Competitors exceeds 12.

In doing so, the FIA will first allocate the PU supply between the PU Manufacturers that are supplying the fewest number of Competitors, provided that the Competitors without a supply agreement shall be allocated to the PU Manufacturer(s) that supply or supplies the fewest Competitors and so on and so forth. If there is more than one PU Manufacturer supplying the fewest number of Competitors (i.e. in the same position) and/or more than one Competitor requesting a supply the allocation between such PU Manufacturers shall occur by ballot (which ballot shall be transparent and undertaken by the FIA in the presence of a representative of each of the PU Manufacturers and the New Customer Competitors (as defined below) concerned).

Any such allocation made by the FIA in accordance with this Article will have to be formalised by a supply agreement with the relevant Competitor by 1 August of year N-1 at the latest.

A New PU Manufacturer will not be required to comply with the obligation of supply as set out above.

1.2.3 Unless agreed otherwise by the FIA, each of the PU Manufacturers of a homologated PU may not directly or indirectly supply PUs for more than (T+1) teams, with T as defined in Article 1.2.2.

1.2.4 Any PU Manufacturer of a homologated PU wishing to cease the supply of PUs must notify the FIA of its intention to do so no later than 1 January of the year preceding that in which such PUs will no longer be supplied.

1.2.5 The FIA and all the PU Manufacturers may agree in writing to temporarily revise the dates set out in Articles 1.2.1 and 1.2.2 of this Appendix.

1.3 Obligation to the supply Power Units to a New Customer Competitor for the year N

The FIA shall be entitled to request a PU Manufacturer to supply a Competitor (“New Customer Competitor”) with a PU under the terms of this Appendix except if, at the date set out in Article 1.2.1 of this Appendix above:

Such Competitor has entered into a supply agreement with a PU Manufacturer for year N before the date set out in Article 1.2.1 of this Appendix above, and

Such Competitor has been granted a right, under a currently binding offer with a PU Manufacturer, to be supplied with a PU for year N.

Moreover, such PU Manufacturer shall only be required to supply a New Customer Competitor if the following cumulative conditions are met. If such conditions are not met, then the PU Manufacturer may, at its sole and absolute discretion, decline the request to supply such New Customer Competitor and the decline of such request shall not be deemed to be a breach of the terms set out in this Appendix. However, this Article 1.3 cannot be applied or interpreted by the PU Manufacturer in a way that would deprive the obligation of supply as referred to in Article 1.2 of this Appendix above of any effect and/or that would prevent the FIA from making and enforcing the provisions set out in Article 1.2 of this Appendix.

The PU Manufacturer undertakes to exercise in good faith the conditions referred to in Articles 1.3.1 to 1.3.11 below).

The Competitors and the PU Manufacturers remain free to negotiate the terms of the supply agreement, subject to the fall-back positions set out below which shall apply should a Competitor and a PU Manufacturer fail to reach an agreement, despite negotiating in good faith.

1.3.1 For the purpose of this Article 1.3.1, supply contract only refers to the contract related to the FIA Supply Perimeter as set out in the relevant column of the two tables in Appendix C4.

- a. Any supply contract entered into with the New Customer Competitor must be on substantially the same terms as those entered into between the PU Manufacturer and the other customer Competitors (other than its appointed “works/factory” Competitor) to whom it already supplies a PU at the date of the FIA request (“Existing Customer Competitor”), other than the Price as referred to in paragraph 8 below. In particular, the PU Manufacturer may impose, and the Competitor cannot refuse to sign up to any terms which at least one of its other Existing Customer Competitors has agreed to and the PU Manufacturer may refuse and the Competitor cannot request the inclusion of terms which are not included in the supply agreements with other Existing Customer Competitors.
- b. In the event that a PU Manufacturer has not supplied a PU to any other Existing Customer Competitor, the PU Manufacturer shall have the right to decide, at its sole and exclusive discretion, the payment terms and conditions (including the price of additional goods and services not included in the supply perimeter designated “EXC” in the relevant column of the two tables in Appendix C4, but excluding the Price which shall be determined in compliance with the definition of Price below) applicable to the New Customer Competitor subject to the provisions of paragraph 1.3.8 below.
- c. In case of a dispute about the application or the interpretation of paragraph 1.3.1 hereto, the FIA will be entitled to request copies of the contracts being entered into by the PU Manufacturer with any customer Competitor, provided that such contracts are not disclosed to any new Customer Competitor and subject to the FIA agreeing to comply with strict customary confidentiality obligations.

1.3.2 The PU Manufacturer shall determine, at its sole and absolute discretion, the duration of the term of the PU supply which:

- a. may not be less than one Championship season; and

- b. shall not exceed three Championship seasons nor go beyond the end of the 2030 Championship season, unless jointly agreed by the PU Manufacturer and the New Customer Competitor
- 1.3.3** The PU Manufacturer shall determine, at its sole and absolute discretion, whether the New Customer Competitor shall use the name of the PU Manufacturer or the New Customer Competitor shall operate under a white label/unbranded way and, for this purpose, use a different name:
- a. The use of this different name shall always be agreed in advance by the PU Manufacturer, which agreement shall not be unreasonably withheld; and
- b. In the event that the white label/unbranded supply is required without being requested by the New Customer Competitor, this supply will not incur additional fees for the New Customer Competitor except if the use of the PU name leads to the conclusion of a commercial agreement between the New Customer Competitor and any third party. In that case, the PU Manufacturer and the New Customer Competitor shall enter into good faith negotiations and shall commonly agree on the fair and reasonable part of the revenues generated by the commercial agreement which could be considered as additional fees;
- c. In the event that the white label/unbranded supply is requested by the New Customer Competitor and agreed by the PU Manufacturer, this supply may incur additional fees for the New Customer Competitor, such fees being determined at the sole and exclusive discretion of the PU Manufacturer in a fair and reasonable manner.
- 1.3.4** The New Customer Competitor shall provide a warranty that it has no binding contracts or option(s) in place with another PU manufacturer for future supply of PUs. The New Customer Competitor shall be required to terminate any such contracts or option(s) which do exist in so far as they conflict with any part of the period of the contract being entered into with the PU Manufacturer.
- 1.3.5** Neither the New Customer Competitor nor any of its affiliated companies shall be an Automotive Manufacturer set up with the purpose of (amongst other things) of participating in the Championship, unless otherwise agreed by the PU Manufacturer.
- 1.3.6** The New Customer Competitor shall not have any sponsorship agreement in place with any entity that is in **competition** with the Core Activities of an Automotive Manufacturer which are also carried out by the PU Manufacturer, unless otherwise agreed by the PU Manufacturer.
- 1.3.7** The New Customer Competitor and/or any senior executives, directors or beneficial shareholders of the New Customer Competitor must not at any time (i) be listed or included in the official EU and/or US published sanction lists; (ii) have been convicted of any indictable criminal offence; (iii) have been convicted by any government or government agency in connection with fraud, money laundering, racketeering or terrorism activities; and/or (iv) have been declared bankrupt; and/or (v) have committed any other identified action which, in the reasonable opinion of the PU Manufacturer, harms the reputation of such PU Manufacturer. This clause shall also reciprocally apply to the PU Manufacturer.
- 1.3.8** The PU Supply Perimeter listed in the relevant column of the two tables in Appendix C4 and designated “INC” shall be supplied to New Customer Competitors at no more than the maximum supply price set out in Article 1.4 of this Appendix.

The supply of additional goods or services not listed in Appendix C4 (which shall be agreed between the PU Manufacturer and the New Customer Competitor) shall incur additional charges, the amount of which shall be substantially the same as that applied by the PU Manufacturer to its Existing Customer Competitor. In the event that a PU Manufacturer has not supplied a PU to any other Existing Customer Competitor, the PU Manufacturer shall decide the price of the above-mentioned additional goods and services based on the usages and practices generally recognised and respected in the market for the supply of parts and services in the Championship.

1.3.9 The FIA shall confirm in writing to the PU Manufacturer that, to the best of its knowledge, the New Customer Competitor, including its officers, directors and beneficial shareholders, has not been convicted of non-complying at all times with the FIA Code of Good Standing.

1.3.10 Payment of the fees (directly or indirectly through a payment guarantee) under the supply contract for each season shall as a fall-back position (unless otherwise agreed between the PU Manufacturer and the New Customer Competitor) and, notwithstanding the terms of any contract with an Existing Customer Competitor or its own factory Competitor, be made in four instalments:

25% on the date of signature of the supply contract;

25% on or before 30 October of year N-1;

30% before the start of the Championship season (year N); and

The remaining 20% before the fifth Formula One Event of the Championship (year N).

The following additional provisions apply:

- a. In case of any delayed payment for an amount greater than €100,000, the PU Manufacturer shall send the New Customer Competitor a written notice of the breach, with a copy to the FIA and the Commercial Rights Holder. Should the New Customer Competitor fail to resolve this breach to the satisfaction of the PU Manufacturer (with or without the involvement of the FIA and the Commercial Rights Holder) within thirty days from the issuing of this notice the PU Manufacturer shall be entitled to either terminate the supply contract immediately by serving written notice on the New Customer Competitor, with a copy to the FIA and the Commercial Rights Holder, or, suspend delivery of the PUs to the New Customer Competitor.
- b. In case of breach of the obligation to deliver the PUs and/or to supply additional goods or services to the New Customer Competitor pursuant to the supply agreement, such New Customer Competitor may send the PU Manufacturer a written notice of the breach (but only in the event that the New Customer Competitor is not itself in breach of contract including for non-payment except if that non-payment is justified by an alleged breach of the supply contract by the PU Manufacturer), with a copy to the FIA and the Commercial Rights Holder. Should the PU Manufacturer fail to resolve this breach to the satisfaction of the New Customer Competitor (with or without the involvement of the FIA and the Commercial Rights Holder) within thirty days from the issuing of this notice the New Customer Competitor shall be entitled to suspend payment of the fees to the PU Manufacturer.

1.3.11 The New Customer Competitor and the PU Manufacturer shall not take any action and/or make any omission, deceptive, misleading or disparaging or negative comments, which directly injures, damages or brings into disrepute the public reputation, goodwill or favourable name or image of the other party to the supply agreement. Both parties will procure their affiliates and/or their respective senior executives, employees, directors and shareholders to abide by the same provisions.

1.4 Power unit maximum supply price

The PU supply perimeter listed in the corresponding column of Appendix C4 shall be supplied at the maximum price of 17 million euros, adjusted for Indexation. For the purpose of this article, Indexation has the meaning indicated, and will be calculated pursuant to the methodology set forth, in Appendix 1 of the Formula 1 **Power Unit** Financial Regulations. The supply of additional goods or services not listed in the Appendix hereto (which shall be agreed between the PU Manufacturer and the Competitor) shall incur additional charges, the amount of which shall be based on the usages and practices generally recognised and respected in the market.

2 Obligations in order to supply Fuel and Engine Oil to a Competitor

2.1 Obligations of Fuel and Engine Oil Suppliers

2.1.1 Any supplier wishing to supply fuel and/or engine oil to a Competitor in any Championship in the period 2026-2030, starting in year N (“Prospective Supplier”) must:

- a. Complete the Fuel and/or Engine Oil Supplier registration form, no later than 1 January of year N-1;
- b. **pay the invoices issued by the FIA as per the fee structure documented in FIA-F1-DOC-C004-A Sustainable Fuel Certification Programme, with regard to the compliance process as defined in Article C16.4 of the Technical Regulations.**
- c. agree to be bound by and to observe the provisions of the **ISC**, the FIA F1 Regulations - Section C [Technical], the FIA F1 Regulations - Section B [Sporting], the Judicial and Disciplinary Rules and all other relevant and applicable FIA rules and/or regulations (as supplemented or amended from time to time);
- d. agree to be bound by the provisions of Article 2.1.2 of this Appendix with regard to the applicability of any patents or pending patent applications to the 2026-2030 Formula 1 World Championships;
- e. agree to be subject to the jurisdiction of the internal judicial and disciplinary bodies of the FIA.
- f. enter into an agreement in the form prescribed by the FIA (“Prospective Supplier Non-Assert Agreement”) with the FIA and the Commercial Rights Holder, pursuant to which the Prospective Supplier agrees not to assert any rights or claims with regard to patents, pending patent applications, or any licensed rights in respect of patents or patent applications against the FIA, the Commercial Rights Holder, any other Fuel and/or Engine Oil Suppliers, all PU Manufacturers and Competitors related to the following:
 - i. blending, processing, developing importing, exporting, testing and/or storing of fuel or engine oil intended for use in Formula 1 in the period 2026-2030. Such provision applies (but is not limited to) the use of any such fuel or engine oil used for development of the fuel or engine oil itself, for the development of the PU by the PU Manufacturer, for track testing or during **Competitions**; and/or

- ii. the setting of the Technical Regulations or any activities arising therefrom, or any activities arising out of the compliance with any mandatory or optional requirement of the Technical Regulations.
- 2.1.2** The Prospective Supplier Non-Assert Agreement shall apply to the Prospective Supplier and any of its affiliate companies.
- 2.1.3** For the avoidance of doubt, the Prospective Supplier Non-Assert Agreement shall not impose an obligation on the Prospective Supplier to supply fuel and/or engine oil for use in any Championship in the period 2026-2030. However, the FIA has the right (in its sole discretion) to refuse the participation in the Championship of any Prospective Supplier that does not enter into the Prospective Supplier Non-Assert Agreement within 30 days of being invited to do so by the FIA.
- 2.1.4** The Prospective Supplier Non-Assert Agreement shall remain binding and valid in respect of any Prospective Supplier that supplies fuel and/or engine oil in any of the 2026-2030 Championships and then subsequently ceases to do so.
- 2.1.5** Each Prospective Supplier warrants that the fuel and/or engine oil that it manufactures and/or supplies for use in the Championships staged during the 2026-2030 period (or subsequent period) (“Relevant Period”) do not infringe the Intellectual Property Rights of any third party, and indemnifies the FIA and its affiliates and the Commercial Rights Holder and its affiliates against all liabilities suffered or incurred by such entities arising out of or in connection with any claim that the fuel and/or engine oil that it manufactures and/or supplies for use in the Championship during the Relevant Period infringe(s) the Intellectual Property Rights of any third party. In this context “Intellectual Property Rights” means: (i) patents, rights to inventions, designs, copyright and related rights, database rights, trade marks, related goodwill and the right to sue for passing off and/or unfair **competition** and trade names, in each case whether registered or unregistered; (ii) proprietary rights in domain names; (iii) knowhow, trade secrets and confidential information; (iv) applications, extensions and renewals in relation to any of these rights; and (v) all other rights of a similar nature or having an equivalent effect anywhere in the world

2.2 Obligations of Competitors and PU Manufacturers with respect to Fuel and Oil Suppliers

2.2.1 PU Manufacturers

- a. Within 90 days of being registered to supply PUs in one or more Championship in the 2026-2030 period under the provisions of Article 1.1 of this Appendix, a PU Manufacturer must nominate in writing to the FIA the Prospective Supplier(s) with whom it intends to develop its PU.

The PU Manufacturer may change its Fuel and/or Oil Supplier at any time, provided the provisions of this Article and Articles 2.1.2 – 2.1.5 are met in relation to any subsequent Prospective Supplier.

Following the nomination of the Prospective Supplier(s), the FIA will invite Prospective Supplier(s) to enter into a Prospective Supplier Non-Assert Agreement in the form prescribed by the FIA pursuant to the provisions of Articles 2.1.2 – 2.1.5 above. Should a Prospective Supplier fail to enter into the Prospective Supplier Non-Assert Agreement within 30 days of being invited to do so by the FIA, the FIA will inform the PU Manufacturer whether, as a result of that failure, the PU Manufacturer will be required to find a different Fuel and/or Oil Supplier.

The FIA reserves the right, at its absolute discretion, to exempt a PU Manufacturer from the nomination requirement, if it is evident that the PU Manufacturer has not entered into an agreement with a Prospective Supplier within 90 days of its registration as a PU Manufacturer. In such cases, if the PU Manufacturer subsequently enters into an agreement with a Prospective Supplier, it must notify the FIA within 30 days of having done so.

- b. The following information cannot be shared between a PU Manufacturer and any Existing or Prospective Fuel/Oil Supplier:
 - i. Any drawing and/or CAD and/or any physical parts (such as but not limited to piston, **cylinder head**, etc.) of the **combustion chamber**
 - ii. Any information relating to gas exchange within the **combustion chamber** (such as but not limited to cams, ports, plenum, exhausts, cam timing, etc.), apart from cylinder pressure data, simulation and dyno test results.

No PU Manufacturer may use the movement of personnel (whether employee, consultant, contractor, secondee or any other type of permanent or temporary personnel) with an Existing or Prospective Fuel/Oil Supplier or another PU Manufacturer, either directly or via an external entity, for the purpose of obtaining an Intellectual Property transfer and/or circumventing the requirements of this Article. In order that the FIA may be satisfied that any such movement of staff is compliant with this Article, each PU Manufacturer must inform the FIA of all relevant staff movements at the end of each calendar quarter using the template which may be found in the Appendix to the Technical and Sporting Regulations and must demonstrate that they have implemented all reasonable measures to avoid the disclosure of Intellectual Property, including but not limited to that explicitly detailed in this Article, between the PU Manufacturer and an Existing or Prospective Fuel/Oil Supplier involved.

2.2.2 Competitors

In the case of Competitors participating in the 2022-2025 Championships (and in relation to whom Article 2.2.1 is inapplicable), the FIA invites each such Competitor to nominate in writing to the FIA their Prospective Supplier(s) within 90 days of: (i) the first publication of these Technical Regulations; or (ii) entering into a commercial or supply agreement with its pre-existing Fuel and/or Engine Oil Supplier in relation to any of the 2026-2030 Championships, whichever is earlier.

Following the nomination of the Prospective Supplier(s), the FIA will invite such Prospective Supplier(s) to enter into a Prospective Supplier Non-Assert Agreement in the form prescribed by the FIA, pursuant to the provisions of Articles 2.1.2 – 2.1.5 above. Should a Prospective Supplier fail to enter into the Prospective Supplier Non-Assert Agreement within 30 days of being invited to do so by the FIA, the FIA will inform the Competitor whether, as a result of that failure, they will be required to find a different Fuel and/or Engine Oil Supplier.

Each Competitor has the right to change their Fuel and/or Engine Oil Supplier at any time, provided the provisions of this Article and Articles 2.1.2 – 2.1.5 are met in relation to any subsequent Prospective Supplier.

3 Non-exclusivity of technologies, licences, patents, and pending patent applications

3.1 Non-exclusivity

With the exception of agreements relating to the supply of fuel and/or engine oil, no PU Manufacturer may enter into a supply agreement with a third-party supplier that is exclusive, or that prevents an equally advantageous supply of a PU component or technology supplied by the third-party supplier in question to another PU Manufacturer.

For the avoidance of doubt, provisions of a supply agreement prohibiting a third party supplier from disclosing to third parties (whether directly or indirectly) a PU Manufacturer's Intellectual Property and/or any information in respect of its LPUCs shall not breach this provision.

3.2 Licences, patents and pending patent applications

The existence of: (i) patents; (ii) pending patent applications; or (iii) any licensed rights in respect of patents or patent applications of a PU Manufacturer shall not prevent any other PU Manufacturer from using any technology, design, or concept in their PUs in Formula 1. To achieve this objective the following provisions must be met:

- a. In registering to supply PUs for the period 2026-2030, the PU Manufacturer must enter into an agreement in the form prescribed by the FIA ("PU Manufacturer Non-Assert Agreement") with the FIA and the Commercial Rights Holder pursuant to which the PU Manufacturer agrees not to assert any rights or claims with regard to patents, pending patent applications, or any licensed rights in respect of patents or patent applications related to PUs against the FIA, the Commercial Rights Holder, any other PU Manufacturers, any suppliers to other PU Manufacturers, or the Competitors.
- b. If the PU Manufacturer obtains any component, design, process or technology relating to a PU from a third-party supplier (the "Third Party Input"), it must obtain written confirmation from the third party supplier in question that the third party supplier will also be bound by the obligations in the PU Manufacturer Non-Assert Agreement as if it was a party to that agreement. Such confirmation should be in the form or substantially the form of the "Supplier Confirmation" at Schedule 2 to the PU Manufacturer Non-Assert Agreement. Failure by the PU Manufacturer to obtain such a confirmation and provide it to the FIA upon request will be considered a breach of these Technical Regulations and may result in the PU or PU component in question that incorporates the third-Party Input not being permitted.

For the avoidance of doubt, this Article regards solely the use of a technology, design or concept in a Formula 1 PU, and does not regard any use of such a technology, design or concept by affiliates of the PU Manufacturer in any other sector.

3.3 PU Manufacturer Warranty

Each PU Manufacturer warrants that the **Power Units** that manufacturers and/or supplies for use in the Championships staged during the 2026-2030 period (or subsequent period, if extended) ("Relevant Period") do not infringe the Intellectual Property Rights of any third party, and indemnifies the FIA and its affiliates and the Commercial Rights Holder and its affiliates against all liabilities suffered or incurred by such entities arising out of or in connection with any claim that the **Power Units** that it manufactures and/or supplies for use in the Championship during the Relevant Period infringe the Intellectual Property Rights or any third party. In this context "Intellectual

Property Rights” means: (i) patents, rights to inventions, designs, copyright and related rights, database rights, trade marks, related goodwill and the right to sue for passing off and/or unfair **competition** and trade names, in each case whether registered or unregistered; (ii) proprietary rights in domain names; (iii) knowhow, trade secrets and confidential information; (iv) applications, extensions and renewals in relation to any of these rights; and (v) all other rights of a similar nature or having an equivalent effect anywhere in the world.

4 **Material breach of the Regulations**

In the case of any alleged material breach or alleged material failure by a PU Manufacturer to comply with any of the obligations of this Appendix, the FIA shall engage in good faith and active discussions with the PU Manufacturer and, in the absence of an amicable solution within one month, be entitled to commence proceedings before the FIA International Tribunal against the PU Manufacturer in respect of such alleged breach or failure. In the event that (in accordance of the provisions of the **JSC** and of the Judicial and Disciplinary Rules), the International Tribunal rules that the PU Manufacturer has materially breached or materially failed to comply with this Appendix, the International Tribunal may impose on the PU Manufacturer concerned, to the exclusion of any other sanction it may have the power to impose, a fine (the amount of which shall be no more than fifteen million euros and shall be determined, on a case by case basis, depending on the merits and circumstances of the applicable case).

5 **New PU Manufacturers**

5.1 **Definition of a New PU Manufacturer**

A PU Manufacturer intending to supply PUs for the first time in year N, will be considered to be a “New PU Manufacturer” if it (or any related party):

- a. has not homologated a PU at least once in the period 2014-2021; and
- b. has not received any significant recent Intellectual Property from a PU Manufacturer who is not a New PU Manufacturer, subject to the conditions outlined in Article 5.2 of this Appendix.

(together, for this Article 5 only, the “Necessary Conditions”)

The “New PU Manufacturer” status will be granted by the FIA, at its absolute discretion, for the complete calendar years from N-3 to N+1.

In order to be granted the “New PU Manufacturer” status, the PU Manufacturer in question must, upon the request of the FIA, provide the FIA with all of the detailed information or documents requested by the FIA describing the commercial background and details of the PU Manufacturer’s business, the Intellectual Property owned by the PU Manufacturer and the technical relationship between the PU Manufacturer and any other related entity or persons (the “Requested Documentation”).

PU Manufacturers granted a “New PU Manufacturer” status are given additional rights or exemptions in certain provisions of the Technical, Sporting and Financial Regulations.

In order to assess whether the Necessary Conditions have been satisfied by a PU Manufacturer, the FIA will assess the Requested Documentation provided by the PU Manufacturer with regard to three factors:

- a. Infrastructure: the necessity for the PU Manufacturer to build facilities, invest significantly in assets, and hire personnel with prior Formula 1 experience;
- b. ICE status: the prior experience of the PU Manufacturer in Formula 1 Internal Combustion Engines, and potential possession of significant recent Intellectual Property; and
- c. ERS status: the prior experience of the PU Manufacturer in Formula 1 ERS systems, and potential possession of significant recent Intellectual Property.

5.2 Partial New PU Manufacturer status

If, following a review of the Requested Documentation, the FIA determines that a PU Manufacturer does not fully satisfy the Necessary Conditions, the FIA reserves the right, at its absolute discretion, to grant the PU Manufacturer a partial New PU Manufacturer status. Partial New PU Manufacturer status will give rise to a reduction of the additional rights accorded to New PU Manufacturers by the Technical, Sporting and Financial Regulations.

The level of reduction of additional rights applied to holders of partial New PU Manufacturer status will be determined according to the weights shown on the following table:

		Regulations Influenced by criteria	
		Financial Regulations: Cost cap and CapEx limits	Technical or Sporting Regulations
Param.	Infrastructure	40% *	20% *
	ICE status	50% *	50% *
	ERS status	10% *	30% *
Outcome:		sum of three parameters	0% or 100% **

* For each parameter, these weightings are allocated either in full or at zero value, depending on the criteria met by the PU Manufacturer

** For Technical or Sporting Regulations, the Newcomer status is awarded either in full (if the sum of the three parameters is greater or equal to 50%), or at zero value.

5.3 Revocation of the New PU Manufacturer status

The FIA reserves the right, at its absolute discretion to revoke a PU Manufacturer's New PU Manufacturer status if:

- a. it becomes apparent that any of the information provided to the FIA by the PU Manufacturer as part of the Requested Documentation that led to the status being granted have changed in a significant manner; or
- b. new evidence comes to light indicating that erroneous information has been provided by the PU Manufacturer to the FIA as part of the Requested Documentation.

The knowing provision by a PU Manufacturer of false or misleading information in the Requested Documentation shall be considered a material breach of these Technical Regulations and will be treated by the FIA in accordance with Article 4 of this Appendix.

5.4 Transparency

Should a PU Manufacturer be awarded the New PU Manufacturer status (or a partial such New Manufacturer status), the FIA will communicate this to all other PU Manufacturers, alongside a

detailed report on such status. The report will include the two percentage scores to be determined in accordance with Article 5.2 of this Appendix and will explain the reasons for the FIA's decision, whilst withholding any confidential information.

5.5 **No right of appeal**

PU Manufacturers shall have no right of appeal against any decision by the FIA in relation to the provisions of this Appendix 5.

6 **Definitions**

6.1 An **Automotive Manufacturer** is a Manufacturer of at least one model of automobile (as defined in the **ISC**) that has produced at least 3,000 units during the past 12 months.

6.2 The **Core Activities** of an Automotive Manufacturer are the Design, production and sale of automobiles (as defined in the **ISC**).